

USER GUIDE

FM-1000™ Plus Application

Version 3.0

Revision A

August 2015

Corporate Office

Trimble Navigation Limited
935 Stewart Drive
Sunnyvale, CA 94085
USA
www.trimble.com

Agriculture

10368 Westmoor Drive
Westminster, Colorado 80021
USA
800-361-1249 (toll free in USA)
+1-937-245-5154 Phone
+1-937-233-9441 Fax
www.trimble.com
Email: trimble_support@trimble.com

Legal Notices

© 2015 Trimble Navigation Limited. All rights reserved.
Trimble, the Globe & Triangle logo, EZ-Boom, EZ-Guide, EZ-Pilot, EZ-Steer, FarmWorks Software, FmX, GreenSeeker, OmniSTAR, Trimble Ready, Tru Count Air Clutch, and WM-Drain are trademarks of Trimble Navigation Limited, registered in the United States and in other countries.
Autopilot, AutoSense, CenterPoint, CFX-750, Connected Farm, EZ-Remote, Farm Works, Farm Works Mapping, Farm Works Software, Field-IQ, FieldLevel, FM-750, FM-1000, FreeForm, LiquiBlock, NextSwath, Rawson, RTX, T3, TMX-2050, FreeForm, TrueGuide, TrueTracker, VRS Now, VRS, WM-Topo, XCN-2050, xFill, and Zephyr are trademarks of Trimble Navigation Limited.
For STL support, the software uses the Moscow Center for SPARC Technology adaptation of the SGI Standard Template Library. Copyright © 1994 Hewlett-Packard Company, Copyright © 1996, 97 Silicon Graphics Computer Systems, Inc., Copyright © 1997 Moscow Center for SPARC Technology.
Portions Copyright © 2009 Nokia Corporation and/or its subsidiary(-ies).
Portions Copyright © 2003, Bitstream Inc.
All other trademarks are the property of their respective owners.

Release Notice

This is the August 2015 release (Revision A) of the FM-1000 Plus application documentation. It applies to version 3.0 of the display software.

Legal Notices

The following limited warranties give you specific legal rights. You may have others, which vary from state/jurisdiction to state/jurisdiction.

Product Limited Warranty

Trimble warrants that this Trimble product and its internal components (the "Product") shall be free from defects in materials and workmanship and will substantially conform to Trimble's applicable published specifications for the Product for a period of one (1) year, starting from the earlier of (i) the date of installation, or (ii) six (6) months from the date of original Product shipment from Trimble. This warranty applies only to the Product if installed by Trimble or a dealer authorized by Trimble to perform Product installation services.

Software Components

All Product software components (sometimes hereinafter also referred to as "Software") are licensed solely for use as an integral part of the Product and are not sold. Any software accompanied by a separate end user license agreement ("EULA") shall be governed by the terms, conditions, restrictions and limited warranty terms of such EULA notwithstanding the preceding paragraph.
During the limited warranty period you will be entitled to receive such Fixes to the Product software that Trimble releases and makes commercially available and for which it does not charge separately, subject to the procedures for delivery to purchasers of Trimble products generally. If you have purchased the Product from an authorized Trimble dealer rather than from Trimble directly, Trimble may, at its option, forward the software Fix to the Trimble dealer for final distribution to you. Minor Updates, Major Upgrades, new products, or substantially new software releases, as identified by Trimble, are expressly excluded from this update process and limited warranty.

Receipt of software Fixes or other enhancements shall not serve to extend the limited warranty period.

For purposes of this warranty the following definitions shall apply: (1) "Fix(es)" means an error correction or other update created to fix a previous software version that does not substantially conform to its Trimble specifications; (2) "Minor Update" occurs when enhancements are made to current features in a software program; and (3) "Major Upgrade" occurs when significant new features are added to software, or when a new product containing new features replaces the further development of a current product line. Trimble reserves the right to determine, in its sole discretion, what constitutes a Fix, Minor Update, or Major Upgrade.

Gson components licensed under the Apache 2.0 License. The source is available from <http://code.google.com/p/google-gson/>. Google MVEL components licensed under the Apache 2.0 License. The source is available from <http://code.google.com/p/mvel.codehouse.org>. Google Guava components listed under the Apache 2.0 License. The source is available from <http://code.google.com/p/guava-libraries>. MapQuest content licensed under the Open Data Commons Database License (DbCL). The source is available from <http://developer.mapquest.com>.
APACE LICENSE (Version 2.0, January 2004)

<http://www.apache.org/licenses/>
TERMS AND CONDITIONS FOR USE,
REPRODUCTION, AND DISTRIBUTION

1. Definitions

"License" shall mean the terms and conditions for use, reproduction, and distribution as defined by Sections 1 through Section 9 of this document.
"Licensor" shall mean the copyright owner or entity authorized by the copyright owner that is granting the License.

"Legal Entity" shall mean the union of the acting entity and all other entities that control, are controlled by, or are under common control with that entity. For the purposes of this definition, "control" means (i) the power, direct or indirect, to cause the direction or management of such entity, whether by contract or otherwise, or (ii) ownership of fifty percent (50%) or more of the outstanding shares, or (iii) beneficial ownership of such entity.

"You" (or "Your") shall mean an individual or Legal Entity exercising permissions granted by this License.

"Source" form shall mean the preferred form for making modifications, including but not limited to software source code, documentation source, and configuration files.

"Object" form shall mean any form resulting from mechanical transformation or translation of a Source form, including but not limited to compiled object code, generated documentation, and conversions to other media types.

"Work" shall mean the work of authorship, whether in Source or Object form, made available under the License, as indicated by a copyright notice that is included in or attached to the work (an example is provided in the Appendix below).

"Derivative Works" shall mean any work, whether in Source or Object form, that is based on (or derived from) the Work and for which the editorial revisions, annotations, elaborations, or other modifications represent, as a whole, an original work of authorship. For the purposes of this License, Derivative Works shall not include works that remain separable from, or merely link (or bind by name) to the interfaces of, the Work and Derivative Works thereof.

"Contribution" shall mean any work of authorship, including the original version of the Work and any modifications or additions to that Work or Derivative Works thereof, that is intentionally submitted to Licensor for inclusion in the Work by the copyright owner or by an individual or Legal Entity authorized to submit on behalf of the copyright owner. For the purposes of this definition, "submitted" means any form of electronic, verbal, or written communication sent to the Licensor or its representatives, including but not limited to communication on electronic mailing lists, source code control systems, and issue tracking systems that are managed by, or on behalf of, the Licensor for the purpose of discussing and improving the Work, but excluding communication that is conspicuously marked or otherwise designated in writing by the copyright owner as "Not a Contribution."

"Contributor" shall mean Licensor and any individual or Legal Entity on behalf of whom a Contribution has been received by Licensor and subsequently incorporated within the Work.

2. Grant of Copyright License. Subject to the terms and conditions of this License, each Contributor hereby grants to You a perpetual, worldwide, non-exclusive, no-charge, royalty-free, irrevocable copyright license to reproduce, prepare Derivative Works of, publicly display, publicly perform, sublicense, and distribute the Work and such Derivative Works in Source or Object form.

3. Grant of Patent License. Subject to the terms and conditions of this License, each Contributor hereby grants to You a perpetual, worldwide, non-exclusive, no-charge, royalty-free, irrevocable (except as stated in this section) patent license to make, have made, use, offer to sell, sell, import, and otherwise transfer the Work, where such license applies only to those patent claims licensable by such Contributor that are necessarily infringed by their Contribution(s) alone or by combination of their Contribution(s) with the Work to which such Contribution(s) was submitted. If You institute patent litigation against any entity (including a cross-claim or counterclaim in a lawsuit) alleging that the Work or a Contribution incorporated within the Work constitutes direct or contributory patent infringement, then any patent licenses granted to You under this License for that Work shall terminate as of the date such litigation is filed.

4. Redistribution. You may reproduce and distribute copies of the Work or Derivative Works thereof in any medium, with or without modifications, and in Source or Object form, provided that You meet the following conditions:

You must give any other recipients of the Work or Derivative Works a copy of this License; and

You must cause any modified files to carry prominent notices stating that You changed the files; and

You must retain, in the Source form of any Derivative Works that You distribute, all copyright, patent, trademark, and attribution notices from the Source form of the Work, excluding those notices that do not pertain to any part of the Derivative Works; and

If the Work includes a "NOTICE" text file as part of its distribution, then any Derivative Works that You distribute must include a readable copy of the attribution notices contained within such NOTICE file, excluding those notices that do not pertain to any part of the Derivative Works, in at least one of the following places: within a NOTICE text file distributed as part of the Derivative Works; within the Source form or documentation, if provided along with the Derivative Works; or, within a display generated by the Derivative Works, if and wherever such third-party notices normally appear. The contents of the NOTICE file are for informational purposes only and do not modify the License. You may add Your own attribution notices within Derivative Works that You distribute, alongside or as an addendum to the NOTICE text from the Work, provided that such additional attribution notices cannot be construed as modifying the License.

You may add Your own copyright statement to Your modifications and may provide additional or different license terms and conditions for use, reproduction, or distribution of Your modifications, or for any such Derivative Works as a whole, provided Your use, reproduction, and distribution of the Work otherwise complies with the conditions stated in this License.

5. Submission of Contributions. Unless You explicitly state otherwise, any Contribution intentionally submitted for inclusion in the Work by You to the Licensor shall be under the terms and conditions of this License, without any additional terms or conditions. Notwithstanding the above, nothing herein shall supersede or modify the terms of any separate license agreement you may have executed with Licensor regarding such Contributions.

6. Trademarks. This License does not grant permission to use the trade names, trademarks, service marks, or product names of the Licensor, except as required for reasonable and customary use in describing the origin of the Work and reproducing the content of the NOTICE file.

7. Disclaimer of Warranty. Unless required by applicable law or agreed to in writing, Licensor provides the Work (and each Contributor provides its Contributions) on an "AS IS" BASIS, WITHOUT WARRANTIES OR CONDITIONS OF ANY KIND, either express or implied, including, without limitation, any warranties or conditions of TITLE, NON-INFRINGEMENT, MERCHANTABILITY, or FITNESS FOR A PARTICULAR PURPOSE. You are solely responsible for determining the appropriateness of using or redistributing the Work and assume any risks associated with Your exercise of permissions under this License.

8. Limitation of Liability. In no event and under no legal theory, whether in tort (including negligence), contract, or otherwise, unless required by applicable law (such as deliberate and grossly negligent acts) or agreed to in writing, shall any Contributor be liable to You for damages, including any direct, indirect, special, incidental, or consequential damages of any character arising as a result of this License or out of the use or inability to use the Work (including but not limited to damages for loss of goodwill, work stoppage, computer failure or malfunction, or any and all other commercial damages or losses), even if such Contributor has been advised of the possibility of such damages.

LWGL LICENSE

ODC DATABASE CONTENTS LICENSE

SGI FREE SOFTWARE LICENSE B (Version 2.0, Sept. 18, 2008)

Copyright © 2013 Silicon Graphics, Inc. All Rights Reserved.

Permission is hereby granted, free of charge, to any person obtaining a copy of this software and associated documentation files (the "Software"), to deal in the Software without restriction, including without limitation the rights to use, copy, modify, merge, publish, distribute, sublicense, and/or sell copies of the Software, and to permit persons to whom the Software is furnished to do so, subject to the following conditions:

The above copyright notice including the dates of first publication and either this permission notice or a reference to

<http://oss.sgi.com/projects/FreeB/> shall be included in all copies or substantial portions of the Software.

THE SOFTWARE IS PROVIDED "AS IS", WITHOUT WARRANTY OF ANY KIND, EXPRESS OR IMPLIED, INCLUDING BUT NOT LIMITED TO THE WARRANTIES OF MERCHANTABILITY, FITNESS FOR A PARTICULAR PURPOSE AND NONINFRINGEMENT. IN NO EVENT SHALL SILICON GRAPHICS, INC. BE LIABLE FOR ANY CLAIM, DAMAGES OR OTHER LIABILITY, WHETHER IN AN ACTION OF CONTRACT, TORT OR OTHERWISE, ARISING FROM, OUT OF OR IN CONNECTION WITH THE SOFTWARE OR THE USE OR OTHER DEALINGS IN THE SOFTWARE.

Except as contained in this notice, the name of Silicon Graphics, Inc. shall not be used in advertising or otherwise to promote the sale, use or other dealings in this Software without prior written authorization from Silicon Graphics, Inc.

MAPQUEST PLATFORM TERMS OF USE (Last Updated: November 1, 2011)

Community Edition License Agreement

INTRODUCTION. MapQuest has been helping people find places and get maps and directions for over 40 years. We make the MapQuest APIs, our Open Services (as described at <http://open.mapquestapi.com/>), Community Accounts and other developer services (in short, the "MapQuest Services"), along with the maps, driving directions and other content delivered through the MapQuest Services (the "MapQuest Content"), available without charge to encourage developers to use these services and content in developing their applications and websites. We want you to be creative and build awesome applications and websites that thrill your users. All we ask is that you comply with the terms that are included in these Terms of Use.

We will provide the developer community at-large with support in various forms, such as forums, blog posts or FAQs. Since we're providing the MapQuest Services for free, we don't provide individual technical support or warranties for the Community Services, but if you want to receive technical support and warranties, we have a product for you. Please check out our MapQuest Platform Services Enterprise Edition and learn more about the services we will provide for reasonable fees.

If you choose to use any of the MapQuest Services or if you set up a Community Account, you are agreeing to abide by these Terms of Use and are forming an agreement between yourself and MapQuest, Inc. ("MapQuest"). If you do not want to abide by these Terms of Use, then don't use the MapQuest Services.

LICENSES FROM MAPQUEST TO YOU.

2.1. MapQuest Services License. MapQuest grants you a non-exclusive, non-assignable, non-sublicensable, revocable limited license to use the MapQuest Services during the Term of these Terms of Use as provided by MapQuest in the manner permitted in these Terms of Use.

2.2. MapQuest Content License. MapQuest grants you a non-exclusive, non-assignable, non-sublicensable, revocable limited license access, use, publicly perform and publicly display the MapQuest Content as the MapQuest Content is provided through the MapQuest Services and in the manner permitted by these Terms of Use.

GENERAL RESTRICTIONS, ADDITIONAL LEGAL NOTICE, RESERVATION OF RIGHTS.

3.1. Restrictions. Except as expressly authorized by MapQuest, You must not:

decompile, disassemble, reverse engineer, or otherwise attempt to derive any source code from the MapQuest Services or MapQuest Content, other than the Open Services; interfere or disrupt MapQuest servers or networks, or disobey any network access or security requirements, policies, procedures or regulations of MapQuest (including the enabling of any viruses, Trojan horses, trap doors, back doors, worms, time bombs, cancelbots, adware, spyware or other computer programming routines designed or intended to damage, detrimentally interfere with, surreptitiously intercept or expropriate any system, data or personal information); use the MapQuest Services as a means to engage in conduct that reflects poorly upon, disparages or devalues MapQuest's reputation or goodwill, as determined in MapQuest's sole discretion;

use the MapQuest Services, other than the Open Services, in conjunction with any commercial application not publicly available without charge (other than mobile applications for which users pay a fee to download/install the application). If your application does not fit this criteria and you would like to discuss additional options for using the MapQuest Services please contact info@mapquest.com;

use the MapQuest Services, other than the Open Services, to process or generate data for any third party (other than for end users as expressly permitted hereunder);

use the MapQuest Services with any content or product that falsely expresses or implies that such content or product is sponsored or endorsed by MapQuest;

use the MapQuest Services in conjunction with a site or application which contains or displays adult content or promotes illegal activities, gambling, or the sale of tobacco or alcohol to persons under twenty-one (21) years of age;

3.2. Additional Legal Requirements. In addition to the restrictions set forth in Section 3.1, your use of the MapQuest Services and MapQuest Content is subject to the Additional Legal Requirements which are incorporated and made a part of these Terms of Use. Please read the Additional Legal Requirements carefully as they include usage limits and additional restrictions that may impact your plans for development.

3.3. Reservation of Rights. MapQuest reserves all rights not expressly granted in these Terms of Use and you may not use the MapQuest Services or MapQuest Content in any manner not expressly authorized in these Terms of Use.

LICENSE FROM YOU TO MAPQUEST. If you upload any data, feedback, ideas, suggestions, content, points of interest (including any points of interest that include Trademarks) or other material to MapQuest (collectively "Your Content"), you hereby grant MapQuest a perpetual, worldwide, non-exclusive, royalty-free license to access, archive, reproduce, publicly display, translate, modify the format or the display of, distribute, transmit, stream, cache, overlay, seam, perform, sublicense, and otherwise use Your Content with or without attribution and without financial obligation, in whole or in part, via any method for any purpose. MapQuest makes no assertion of ownership over Your Content, and you retain all intellectual property rights to Your Content, subject to the license you grant to MapQuest above.

MODIFICATIONS TO THESE TERMS OF USE AND THE SERVICES.

MapQuest reserves the right to change or modify these Terms of Use, the MapQuest Services and/or the MapQuest Content. Please check these Terms of Use, including the Additional Legal Requirements periodically for changes. Your continued use of the MapQuest Services or MapQuest Content following the posting of any changes to the Terms of Use constitutes acceptance of those changes.

TERMINATION. MapQuest may terminate these Terms of Use and/or the provision of the MapQuest Services or MapQuest Content at any time, for any reason, with or without notice.

PRIVACY POLICY AND END USER TERMS.

7.1. Privacy Policy. MapQuest's collection and use of personally identifiable information is governed by the AOL Network Privacy Policy, available at http://about.aol.com/aolnetwork/aol_pp.

7.2. End User Terms. End users shall only be entitled to use the MapQuest Services and MapQuest Content if they accept the then current end user Terms of Use located at <http://info.mapquest.com/terms-of-use/>. MapQuest reserves the right to amend and/or replace these terms and the form and manner of presentation. You must provide a hypertext link at the bottom of each page in your website or application where the MapQuest Services or MapQuest Content can be viewed or accessed, or within the terms of use of your application or website, to the end user terms of use.

ACCESS AND USAGE DATA.

8.1. Credentials. MapQuest, at its discretion, may require you to create an account and obtain an access key and other related credentials (collectively "Credentials") to use the MapQuest Services or certain aspects of the MapQuest Services. You are responsible for maintaining the confidentiality of your Credentials and for any usage or abuse of the MapQuest Services or MapQuest Content by anyone using your Credentials.

8.2. Usage Data. MapQuest's servers record information when you visit MapQuest websites or when applications and/or Credentials call or invoke the MapQuest Services. This information may include, without limitation, the URL, IP address, browser type, Credential and access times and dates. MapQuest may use this information to promote, operate, and improve MapQuest services, products and properties.

PROPRIETARY RIGHTS. You acknowledge and agree the MapQuest Services and MapQuest Content are works for purposes of copyright law, and embody valuable, confidential, trade secret information of

MapQuest, the development of which required the expenditure of substantial time and money. As between MapQuest and You, MapQuest retains exclusive ownership of any and all rights, title and interest (including all intellectual property rights) in the MapQuest Services and MapQuest Content, and you shall not acquire any rights, express or implied, in the foregoing by virtue of these Terms of Use other than otherwise expressly set forth. For purposes of these Terms of Use, the term "Trademarks" means all trademarks, trade names, service marks, logos, domain names, along with any other distinctive brand features of MapQuest or its suppliers. All use by You of Trademarks shall inure to the benefit of MapQuest. Further, You shall not (a) display a Trademark as the most prominent element on any page of Your website, application or paper map; (b) display a Trademark in a manner that is misleading, defamatory, infringing, libelous, disparaging, obscene or otherwise objectionable to MapQuest as determined by MapQuest in its sole discretion; or (c) remove, distort or alter any element of a Trademark.

DISCLAIMER OF WARRANTIES. THE MAPQUEST SERVICES AND MAPQUEST CONTENT ARE PROVIDED ON AN "AS IS" AND "AS AVAILABLE" BASIS. MAPQUEST DISCLAIMS ANY AND ALL WARRANTIES, WHETHER EXPRESS OR IMPLIED, INCLUDING BUT NOT LIMITED TO ANY WARRANTIES OF MERCHANTABILITY, FITNESS FOR A PARTICULAR PURPOSE, ACCURACY OR NON-INFRINGEMENT. MAPQUEST DOES NOT REPRESENT OR WARRANT THAT THE MAPQUEST SERVICES OR CONTENT, OR ANY PORTION THEREOF, IS OR WILL BE FREE OF DEFECTS OR ERRORS (OR THAT ANY SUCH DEFECTS OR ERRORS WILL BE CORRECTED), VIRUS FREE, ABLE TO OPERATE ON AN UNINTERRUPTED BASIS, MEET YOUR REQUIREMENTS, OR CAPABLE OF BEING INTEGRATED INTO OR WITH YOUR COMPUTER SYSTEM, APPLICATIONS OR NETWORK. FURTHER, MAPQUEST DOES NOT WARRANT OR MAKE ANY REPRESENTATIONS REGARDING THE USE OR THE RESULTS OF THE USE OF THE MAPQUEST SERVICES, OR ANY PORTION THEREOF, IN TERMS OF ITS CORRECTNESS, ACCURACY, QUALITY, RELIABILITY, OR OTHERWISE. THIS DISCLAIMER CONSTITUTES AN ESSENTIAL PART OF THESE TERMS OF USE. IF THIS EXCLUSION IS HELD UNENFORCEABLE, THEN ALL EXPRESS AND IMPLIED WARRANTIES SHALL BE LIMITED IN DURATION TO A PERIOD OF FIFTEEN (15) DAYS AFTER THE EFFECTIVE DATE, AND NO WARRANTIES SHALL APPLY AFTER THAT PERIOD.

LIMITATION ON LIABILITY. NEITHER MAPQUEST NOR ITS AFFILIATES NOR ANY OF THEIR SUPPLIERS SHALL BE LIABLE TO YOU OR ANY OTHER THIRD PARTY FOR ANY DIRECT, INDIRECT, SPECIAL, INCIDENTAL OR CONSEQUENTIAL DAMAGES OF ANY NATURE ARISING OUT OF THE POSSESSION OF, ACCESS TO, USE OF, OR INABILITY TO ACCESS OR USE THE MAPQUEST SERVICES OR MAPQUEST CONTENT, OR ANY PORTION, INCLUDING, WITHOUT LIMITATION, LOST PROFITS, DATA LOSS, COST OF PROCUREMENT FOR SUBSTITUTE GOODS, OR COMPUTER FAILURE OR MALFUNCTION, EVEN IF MAPQUEST HAS BEEN ADVISED OF THE POSSIBILITY OF SUCH DAMAGES, AND REGARDLESS OF WHETHER THE CLAIM OR LIABILITY IS BASED UPON ANY CONTRACT, TORT, BREACH OF WARRANTY OR OTHER LEGAL OR EQUITABLE THEORY. IN NO EVENT SHALL MAPQUEST'S TOTAL AGGREGATE LIABILITY UNDER THESE TERMS OF USE EXCEED THE LESSER OF (A) THE TOTAL AMOUNT OF FEES PAID BY YOU TO MAPQUEST UNDER THESE TERMS OF USE FOR THE TWELVE (12) MONTHS PRECEDING THE DATE OF THE EVENT GIVING RISE TO SUCH CLAIM; OR (B) FIVE HUNDRED DOLLARS (\$500).

YOU EXPRESSLY ACKNOWLEDGE AND AGREE THAT THE PARTICIPATION IN AND USE OF THE MAPQUEST SERVICES AND MAPQUEST CONTENT IS DONE AT YOUR OWN RISK AND THAT YOU ARE SOLELY RESPONSIBLE AND LIABLE FOR ANY DAMAGE SUSTAINED TO YOUR COMPUTER SYSTEM, NETWORK OR DATA RESULTING FROM SUCH PARTICIPATION OR USE.

SOME JURISDICTIONS DO NOT ALLOW THE EXCLUSION OF CERTAIN WARRANTIES OR THE LIMITATION OR EXCLUSION OF LIABILITY FOR INCIDENTAL OR CONSEQUENTIAL DAMAGES.

INDEMNITY. You agree to indemnify, defend and hold MapQuest and its affiliates, and each of their officers, directors, employees, agents, co-branders or other partners (as well as each of their suppliers), successors and permitted assigns ("Indemnified Parties") harmless from and against any third party claim or action, including any liability, cost, losses, damages, expenses, and attorney's fees, arising from or in any way related to Your access, use or participation in the MapQuest Services (including claims related to Your Content and any use of the MapQuest Services with software, data, content, systems, or other technology not provided by MapQuest), any violation of these Terms of Use, or any alleged infringement of a patent, copyright, trademark, trade secret, or other intellectual property right. MapQuest shall use good faith efforts

to provide you with prompt notice of any such claim or action; provided however, you agree that, upon MapQuest's written request, MapQuest shall control the defense or settlement of any such claim or action and you shall provide reasonable cooperation to MapQuest. You may not settle an indemnifiable claim without obtain MapQuest's prior written consent.

EXPORT RESTRICTIONS. You agree to comply with all export and import laws and restrictions and regulations of the United States or any foreign agency or authority, and not to export or re-export MapQuest Services or any direct product thereof in violation of any such restrictions, laws or regulations, or without all necessary approvals.

NOTICES AND TRANSACTING ELECTRONICALLY. You understand and agree that MapQuest is an online service and that you are transacting with MapQuest electronically. MapQuest shall provide electronic notices by posting them on this website and/or by sending an email to any account associated with your Credentials.

GENERAL PROVISIONS.

15.1. Entire Agreement. These Terms of Use constitute the entire agreement between MapQuest and You with respect to the subject matter of these Terms of Use, and supersedes all prior agreements, understandings and communications between MapQuest and You with respect to such subject matter. No modification or amendment to these Terms of Use shall be effective unless in writing by MapQuest.

15.2. Choice of Law; Jurisdiction. These Terms of Use are made under and shall be governed by and construed in accordance with the laws of the Commonwealth of Virginia (except for its conflicts of laws principles) and specifically excluding f the United Nations Convention on Contracts for the International Sale of Goods. MapQuest and You expressly agree that exclusive jurisdiction for any claim or dispute relating to or arising out of these Terms of Use resides in the state courts in Loudoun County, Virginia and the federal courts of the Eastern District of Virginia (Alexandria Division) and further agree and expressly consent to the exercise of personal jurisdiction in such state and federal courts of Virginia in connection with any such dispute.

15.3. Severability; Waiver. If any provision in these Terms of Use should be held illegal or unenforceable by a court having jurisdiction, such provision shall be modified to the extent necessary to render it enforceable without losing its intent, or severed from these Terms of Use if no such modification is possible, and other provisions of these Terms of Use shall remain in full force and effect. A waiver by either MapQuest or You (as applicable) of any term or condition of these Terms of Use or any breach thereof, in any one instance, shall not waive such term or condition or any subsequent breach thereof.

15.4. Public Statements. You acknowledge and agree that MapQuest may make any public statements regarding the existence of these Terms of Use or the relationship described herein, without Your consent.

15.5. Survival. Any term or condition of these Terms of Use that by its nature would logically survive termination or expiration of these Terms of Use, including but not limited to protections of proprietary rights, indemnifications, and limitations of liability, shall survive such termination or expiration.

15.6. Independent Contractors. The parties to these Terms of Use are independent contractors. Neither party is an agent, representative or partner of the other party. Neither party shall have any right, power or authority to enter into any agreement for or on behalf of, or incur any obligation or liability of, or otherwise to bind, the other party.

15.7. Equitable Remedies. You acknowledge and agree that monetary damages may be insufficient to compensate MapQuest for an actual or anticipated breach of these Terms of Use by you. You agree that in such circumstances MapQuest shall be entitled to seek equitable remedies (including preliminary and permanent injunctions), in addition to any other remedies available to MapQuest at law or hereunder.

15.8. Statute of Limitations. You agree that regardless of any statute or law to the contrary, any claim or cause of action arising out of or related to use of the MapQuest Services or these Terms of Use must be filed by you within one (1) year after such claim or cause of action arose or be forever barred.

15.9. Consent to Further Contacts. You agree that MapQuest may contact You with respect to these Terms of Use, any other MapQuest products and services, and in relation to any marketing related-purposes.

ODC Open Database License (ODbL)

The Open Database License (ODbL) is a license agreement intended to allow users to freely share, modify, and use this Database while maintaining this same freedom for others. Many databases are covered by copyright, and therefore this document licenses these rights. Some jurisdictions, mainly in the European Union, have specific rights that cover databases, and so the ODbL addresses these rights, too. Finally,

the ODbL is also an agreement in contract for users of this Database to act in certain ways in return for accessing this Database.

Databases can contain a wide variety of types of content (images, audiovisual material, and sounds all in the same database, for example), and so the ODbL only governs the rights over the Database, and not the contents of the Database individually. Licensors should use the ODbL together with another license for the contents, if the contents have a single set of rights that uniformly covers all of the contents. If the contents have multiple sets of different rights, Licensors should describe what rights govern what contents together in the individual record or in some other way that clarifies what rights apply.

Sometimes the contents of a database, or the database itself, can be covered by other rights not addressed here (such as private contracts, trade mark over the name, or privacy rights / data protection rights over information in the contents), and so you are advised that you may have to consult other documents or clear other rights before doing activities not covered by this License.

The Licensors (as defined below) and You (as defined below) agree as follows:

1.0 Definitions of Capitalised Words

"Collective Database" – Means this Database in unmodified form as part of a collection of independent databases in themselves that together are assembled into a collective whole. A work that constitutes a Collective Database will not be considered a Derivative Database.

"Convey" – As a verb, means Using the Database, a Derivative Database, or the Database as part of a Collective Database in any way that enables a Person to make or receive copies of the Database or a Derivative Database. Conveying does not include interaction with a user through a computer network, or creating and Using a Produced Work, where no transfer of a copy of the Database or a Derivative Database occurs.

"Contents" – The contents of this Database, which includes the information, independent works, or other material collected into the Database. For example, the contents of the Database could be factual data or works such as images, audiovisual material, text, or sounds.

"Database" – A collection of material (the Contents) arranged in a systematic or methodical way and individually accessible by electronic or other means offered under the terms of this License.

"Database Directive" – Means Directive 96/9/EC of the European Parliament and of the Council of 11 March 1996 on the legal protection of databases, as amended or succeeded.

"Database Right" – Means rights resulting from the Chapter III ("suigeneris") rights in the Database Directive (as amended and as transposed by member states), which includes the Extraction and Re-utilisation of the whole or a Substantial part of the Contents, as well as any similar rights available in the relevant jurisdiction under Section 10.4.

"Derivative Database" – Means a database based upon the Database, and includes any translation, adaptation, arrangement, modification, or any other alteration of the Database or of a Substantial part of the Contents. This includes, but is not limited to, Extracting or Re-utilising the whole or a Substantial part of the Contents in a new Database.

"Extraction" – Means the permanent or temporary transfer of all or a Substantial part of the Contents to another medium by any means or in any form.

"License" – Means this license agreement and is both a license of rights such as copyright and Database Rights and an agreement in contract.

"Licensor" – Means the Person that offers the Database under the terms of this License.

"Person" – Means a natural or legal person or a body of persons corporate or incorporate.

"Produced Work" – a work (such as an image, audiovisual material, text, or sounds) resulting from using the whole or a Substantial part of the Contents (via a search or other query) from this Database, a Derivative Database, or this Database as part of a Collective Database.

"Publicly" – means to Persons other than You or under Your control by either more than 50% ownership or by the power to direct their activities (such as contracting with an independent consultant).

"Re-utilisation" – means any form of making available to the public all or a Substantial part of the Contents by the distribution of copies, by renting, by online or other forms of transmission.

"Substantial" – Means substantial in terms of quantity or quality or a combination of both. The repeated and systematic Extraction or Re-utilisation of insubstantial parts of the Contents may amount to the Extraction or Re-utilisation of a Substantial part of the Contents.

"Use" – As a verb, means doing any act that is restricted by copyright or Database Rights whether in the original medium or any other; and includes without limitation distributing, copying, publicly performing,

publicly displaying, and preparing derivative works of the Database, as well as modifying the Database as may be technically necessary to use it in a different mode or format.

"You" – Means a Person exercising rights under this License who has not previously violated the terms of this License with respect to the Database, or who has received express permission from the Licensor to exercise rights under this License despite a previous violation.

Words in the singular include the plural and vice versa.

2.0 What this License covers

2.1. Legal effect of this document. This License is:

- a. A license of applicable copyright and neighbouring rights;
- b. A license of the Database Right; and
- c. An agreement in contract between You and the Licensor.

2.2 Legal rights covered. This License covers the legal rights in the Database, including:

- a. Copyright. Any copyright or neighbouring rights in the Database. The copyright licensed includes any individual elements of the Database, but does not cover the copyright over the Contents independent of this Database. See Section 2.4 for details. Copyright law varies between jurisdictions, but is likely to cover: the Database model or schema, which is the structure, arrangement, and organization of the Database, and can also include the Database tables and table indexes; the data entry and output sheets; and the Field names of Contents stored in the Database;
- b. Database Rights. Database Rights only extend to the Extraction and Re-utilisation of the whole or a Substantial part of the Contents. Database Rights can apply even when there is no copyright over the Database. Database Rights can also apply when the Contents are removed from the Database and are elected and arranged in a way that would not infringe any applicable copyright; and
- c. Contract. This is an agreement between You and the Licensor for access to the Database. In return you agree to certain conditions of use on this access as outlined in this License.

2.3 Rights not covered.

- a. This License does not apply to computer programs used in the making or operation of the Database;
- b. This License does not cover any patents over the Contents or the Database; and
- c. This License does not cover any trademarks associated with the Database.

2.4 Relationship to Contents in the Database. The individual items of the Contents contained in this Database may be covered by other rights, including copyright, patent, data protection, privacy, or personality rights, and this License does not cover any rights (other than Database Rights or in contract) in individual Contents contained in the Database. For example, if used on a Database of images (the Contents), this License would not apply to copyright over individual images, which could have their own separate licenses, or one single license covering all of the rights over the images.

3.0 Rights granted

3.1 Subject to the terms and conditions of this License, the Licensor grants to You a worldwide, royalty-free, non-exclusive, terminable (but only under Section 9) license to Use the Database for the duration of any applicable copyright and Database Rights. These rights explicitly include commercial use, and do not exclude any field of endeavour. To the extent possible in the relevant jurisdiction, these rights may be exercised in all media and formats whether now known or created in the future.

The rights granted cover, for example:

- a. Extraction and Re-utilisation of the whole or a Substantial part of the Contents;
- b. Creation of Derivative Databases;
- c. Creation of Collective Databases;
- d. Creation of temporary or permanent reproductions by any means and in any form, in whole or in part, including of any Derivative Databases or as a part of Collective Databases; and
- e. Distribution, communication, display, lending, making available, or performance to the public by any means and in any form, in whole or in part, including of any Derivative Database or as a part of Collective Databases.

3.2 Compulsory license schemes. For the avoidance of doubt:

- a. Non-waivable compulsory license schemes. In those jurisdictions in which the right to collect royalties through any statutory or compulsory licensing scheme cannot be waived, the Licensor reserves the exclusive right to collect such royalties for any exercise by You of the rights granted under this License;
- b. Waivable compulsory license schemes. In those jurisdictions in which the right to collect royalties through any statutory or compulsory licensing scheme can be waived, the Licensor waives the exclusive right

to collect such royalties for any exercise by You of the rights granted under this License; and,

c. Voluntary license schemes. The Licensor waives the right to collect royalties, whether individually or, in the event that the Licensor is a member of a collecting society that administers voluntary licensing schemes, via that society, from any exercise by You of the rights granted under this License.

3.3 The right to release the Database under different terms, or to stop distributing or making available the Database, is reserved. Note that this Database may be multiple-licensed, and so You may have the choice of using alternative licenses for this Database. Subject to Section 10.4, all other rights not expressly granted by Licensor are reserved.

4.0 Conditions of Use

4.1 The rights granted in Section 3 above are expressly made subject to Your complying with the following conditions of use. These are important conditions of this License, and if You fail to follow them, You will be in material breach of its terms.

4.2 Notices. If You Publicly Convey this Database, any Derivative Database, or the Database as part of a Collective Database, then You must:

- a. Do so only under the terms of this License or another license permitted under Section 4.4;
 - b. Include a copy of this License (or, as applicable, a license permitted under Section 4.4) or its Uniform Resource Identifier (URI) with the Database or Derivative Database, including both in the Database or Derivative Database and in any relevant documentation; and
 - c. Keep intact any copyright or Database Right notices and notices that refer to this License.
- d. If it is not possible to put the required notices in a particular file due to its structure, then You must include the notices in a location (such as a relevant directory) where users would be likely to look for it.

4.3 Notice for using output (Contents). Creating and Using a Produced Work does not require the notice in Section 4.2. However, if you Publicly Use a Produced Work, You must include a notice associated with the Produced Work reasonably calculated to make any Person that uses, views, accesses, interacts with, or is otherwise exposed to the Produced Work aware that Content was obtained from the Database, Derivative Database, or the Database as part of a Collective Database, and that it is available under this License.

a. Example notice. The following text will satisfy notice under Section 4.3: Contains information from DATABASE NAME, which is made available here under the Open Database License (ODbL). DATABASE NAME should be replaced with the name of the Database and a hyperlink to the URI of the Database. "Open Database License" should contain a hyperlink to the URI of the text of this License. If hyperlinks are not possible, You should include the plain text of the required URI's with the above notice.

4.4 Share alike.

a. Any Derivative Database that You Publicly Use must be only under the terms of:

- i. This License;
- ii. A later version of this License similar in spirit to this License; or
- iii. A compatible license.

If You license the Derivative Database under one of the licenses mentioned in (iii), You must comply with the terms of that license.

b. For the avoidance of doubt, Extraction or Re-utilisation of the whole or a Substantial part of the Contents into a new database is a Derivative Database and must comply with Section 4.4.

c. Derivative Databases and Produced Works. A Derivative Database is Publicly Used and so must comply with Section 4.4. if a Produced Work created from the Derivative Database is Publicly Used.

d. Share Alike and additional Contents. For the avoidance of doubt, You must not add Contents to Derivative Databases under Section 4.4 a that are incompatible with the rights granted under this License.

e. Compatible licenses. Licensors may authorise a proxy to determine compatible licenses under Section 4.4 a iii. If they do so, the authorised proxy's public statement of acceptance of a compatible license grants You permission to use the compatible license.

4.5 Limits of Share Alike. The requirements of Section 4.4 do not apply in the following:

a. For the avoidance of doubt, You are not required to license Collective Databases under this License if You incorporate this Database or a Derivative Database in the collection, but this License still applies to this Database or a Derivative Database as a part of the Collective Database;

b. Using this Database, a Derivative Database, or this Database as part of a Collective Database to create a Produced Work does not create a Derivative Database for purposes of Section 4.4; and

c. Use of a Derivative Database internally within an organisation is not to the public and therefore does not fall under the requirements of Section 4.4.

4.6 Access to Derivative Databases. If You Publicly Use a Derivative Database or a Produced Work from a Derivative Database, You must also offer to recipients of the Derivative Database or Produced Work a copy in a machine readable form of:

a. The entire Derivative Database; or

b. A file containing all of the alterations made to the Database or the method of making the alterations to the Database (such as an algorithm), including any additional Contents, that make up all the differences between the Database and the Derivative Database. The Derivative Database (under a.) or alteration file (under b.) must be available at no more than a reasonable production cost for physical distributions and free of charge if distributed over the internet.

4.7 Technological measures and additional terms

a. This License does not allow You to impose (except subject to Section 4.7 b.) any terms or any technological measures on the Database, a Derivative Database, or the whole or a Substantial part of the Contents that alter or restrict the terms of this License, or any rights granted under it, or have the effect or intent of restricting the ability of any person to exercise those rights.

b. Parallel distribution. You may impose terms or technological measures on the Database, a Derivative Database, or the whole or a Substantial part of the Contents (a "Restricted Database") in contravention of Section 4.7 a. only if You also make a copy of the Database or a Derivative Database available to the recipient of the Restricted Database:

i. That is available without additional fee;

ii. That is available in a medium that does not alter or restrict the terms of this License, or any rights granted under it, or have the effect or intent of restricting the ability of any person to exercise those rights (an "Unrestricted Database"); and

iii. The Unrestricted Database is at least as accessible to the recipient as a practical matter as the Restricted Database.

c. For the avoidance of doubt, You may place this Database or a Derivative Database in an authenticated environment, behind a password, or within a similar access control scheme provided that You do not alter or restrict the terms of this License or any rights granted under it or have the effect or intent of restricting the ability of any person to exercise those rights.

4.8 Licensing of others. You may not sublicense the Database. Each time You communicate the Database, the whole or Substantial part of the Contents, or any Derivative Database to anyone else in any way, the Licensor offers to the recipient a license to the Database on the same terms and conditions as this License. You are not responsible for enforcing compliance by third parties with this License, but You may enforce any rights that You have over a Derivative Database. You are solely responsible for any modifications of a Derivative Database made by You or another Person at Your direction. You may not impose any further restrictions on the exercise of the rights granted or affirmed under this License.

5.0 Moral rights

5.1 Moral rights. This section covers moral rights, including any rights to be identified as the author of the Database or to object to treatment that would otherwise prejudice the author's honour and reputation, or any other derogatory treatment:

a. For jurisdictions allowing waiver of moral rights, Licensor waives all moral rights that Licensor may have in the Database to the fullest extent possible by the law of the relevant jurisdiction under Section 10.4;

b. If waiver of moral rights under Section 5.1 a in the relevant jurisdiction is not possible, Licensor agrees not to assert any moral rights over the Database and waives all claims in moral rights to the fullest extent possible by the law of the relevant jurisdiction under Section 10.4; and

c. For jurisdictions not allowing waiver or an agreement not to assert moral rights under Section 5.1 a and b, the author may retain their moral rights over certain aspects of the Database. Please note that some jurisdictions do not allow for the waiver of moral rights, and so moral rights may still subsist over the Database in some jurisdictions.

6.0 Fair dealing, Database exceptions, and other rights not affected

6.1 This License does not affect any rights that You or anyone else may independently have under any applicable law to make any use of this Database, including without limitation:

a. Exceptions to the Database Right including: Extraction of Contents from non-electronic Databases for private purposes, Extraction for purposes of illustration for teaching or scientific research, and Extraction or Re-utilisation for public security or an administrative or judicial procedure.

b. Fair dealing, fair use, or any other legally recognised limitation or exception to infringement of copyright or other applicable laws.

6.2 This License does not affect any rights of lawful users to Extract and Re-utilise insubstantial parts of the Contents, evaluated quantitatively or qualitatively, for any purposes whatsoever, including creating a Derivative Database (subject to other rights over the Contents, see Section 2.4). The repeated and systematic Extraction or Re-utilisation of insubstantial parts of the Contents may however amount to the Extraction or Re-utilisation of a Substantial part of the Contents.

7.0 Warranties and Disclaimer 7.1 The Database is licensed by the Licensor "as is" and without any warranty of any kind, either express, implied, or arising by statute, custom, course of dealing, or trade usage. Licensor specifically disclaims any and all implied warranties or conditions of title, non-infringement, accuracy or completeness, the presence or absence of errors, fitness for a particular purpose, merchantability, or otherwise.

Some jurisdictions do not allow the exclusion of implied warranties, so this exclusion may not apply to You.

8.0 Limitation of liability

8.1 Subject to any liability that may not be excluded or limited by law, the Licensor is not liable for, and expressly excludes, all liability for loss or damage however and whenever caused to anyone by any use under this License, whether by You or by anyone else, and whether caused by any fault on the part of the Licensor or not. This exclusion of liability includes, but is not limited to, any special, incidental, consequential, punitive, or exemplary damages such as loss of revenue, data, anticipated profits, and lost business. This exclusion applies even if the Licensor has been advised of the possibility of such damages.

8.2 If liability may not be excluded by law, it is limited to actual and direct financial loss to the extent it is caused by proved negligence on the part of the Licensor.

9.0 Termination of Your rights under this License

9.1 Any breach by You of the terms and conditions of this License automatically terminates this License with immediate effect and without notice to You. For the avoidance of doubt, Persons who have received the Database, the whole or a Substantial part of the Contents, Derivative Databases, or the Database as part of a Collective Database from You under this License will not have their licenses terminated provided their use is in full compliance with this License or a license granted under Section 4.8 of this License. Sections 1, 2, 7, 8, 9 and 10 will survive any termination of this License.

9.2 If You are not in breach of the terms of this License, the Licensor will not terminate Your rights under it.

9.3 Unless terminated under Section 9.1, this License is granted to You for the duration of applicable rights in the Database.

9.4 Reinstatement of rights. If you cease any breach of the terms and conditions of this License, then your full rights under this License will be reinstated:

a. Provisionally and subject to permanent termination until the 60th day after cessation of breach;

b. Permanently on the 60th day after cessation of breach unless otherwise reasonably notified by the Licensor; or

c. Permanently if reasonably notified by the Licensor of the violation, this is the first time You have received notice of violation of this License from the Licensor, and You cure the violation prior to 30 days after your receipt of the notice.

Persons subject to permanent termination of rights are not eligible to be a recipient and receive a license under Section 4.8.

9.5 Notwithstanding the above, Licensor reserves the right to release the Database under different license terms or to stop distributing or making available the Database. Releasing the Database under different license terms or stopping the distribution of the Database will not withdraw this License (or any other license that has been, or is required to be, granted under the terms of this License), and this License will continue in full force and effect unless terminated as stated above.

10.0 General

10.1 If any provision of this License is held to be invalid or unenforceable, that must not affect the validity or enforceability of the remainder of the terms and conditions of this License and each remaining provision of this License shall be valid and enforced to the fullest extent permitted by law.

10.2 This License is the entire agreement between the parties with respect to the rights granted here over the Database. It replaces any earlier understandings, agreements or representations with respect to the Database.

10.3 If You are in breach of the terms of this License, You will not be entitled to rely on the terms of this License or to complain of any breach by the Licensor.

10.4 Choice of law. This License takes effect in and will be governed by the laws of the relevant jurisdiction in which the License terms are sought to be enforced. If the standard suite of rights granted under applicable copyright law and Database Rights in the relevant jurisdiction includes additional rights not granted under this License, these additional rights are granted in this License in order to meet the terms of this License.

Warranty Remedies

Trimble's sole liability and your exclusive remedy under the warranties set forth above shall be, at Trimble's option, to repair or replace any Product that fails to conform to such warranty ("Nonconforming Product"), and/or issue a cash refund up to the purchase price paid by you for any such Nonconforming Product, excluding costs of installation, upon your return of the Nonconforming Product to Trimble in accordance with Trimble's product return procedures than in effect. Such remedy may include reimbursement of the cost of repairs for damage to third-party equipment onto which the Product is installed, if such damage is found to be directly caused by the Product as reasonably determined by Trimble following a root cause analysis.

Warranty Exclusions and Disclaimer

These warranties shall be applied only in the event and to the extent that (a) the Products and Software are properly and correctly installed, configured, interfaced, maintained, stored, and operated in accordance with Trimble's relevant operator's manual and specifications, and; (b) the Products and Software are not modified or misused. The preceding warranties shall not apply to, and Trimble shall not be responsible for defects or performance problems resulting from (i) the combination or utilization of the Product or Software with hardware or software products, information, data, systems, interfaces or devices not made, supplied or specified by Trimble; (ii) the operation of the Product or Software under any specification other than, or in addition to, Trimble's standard specifications for its products; (iii) the unauthorized, installation, modification, or use of the Product or Software; (iv) damage caused by accident, lightning or other electrical discharge, fresh or salt water immersion or spray (outside of Product specifications); or (v) normal wear and tear on consumable parts (e.g., batteries). Trimble does not warrant or guarantee the results obtained through the use of the Product or that software components will operate error free.

THE WARRANTIES ABOVE STATE TRIMBLE'S ENTIRE LIABILITY, AND YOUR EXCLUSIVE REMEDIES, RELATING TO THE PRODUCTS AND SOFTWARE. EXCEPT AS OTHERWISE EXPRESSLY PROVIDED HEREIN, THE PRODUCTS, SOFTWARE, AND ACCOMPANYING DOCUMENTATION AND MATERIALS ARE PROVIDED "AS IS" AND WITHOUT EXPRESS OR IMPLIED WARRANTY OF ANY KIND BY EITHER TRIMBLE NAVIGATION LIMITED OR ANYONE WHO HAS BEEN INVOLVED IN ITS CREATION, PRODUCTION, INSTALLATION, OR DISTRIBUTION INCLUDING, BUT NOT LIMITED TO, THE IMPLIED WARRANTIES OF MERCHANTABILITY AND FITNESS FOR A PARTICULAR PURPOSE, TITLE, AND NON-INFRINGEMENT. THE STATED EXPRESS WARRANTIES ARE IN LIEU OF ALL OBLIGATIONS OR LIABILITIES ON THE PART OF TRIMBLE ARISING OUT OF, OR IN CONNECTION WITH, ANY PRODUCTS OR SOFTWARE. BECAUSE SOME STATES AND JURISDICTIONS DO NOT ALLOW LIMITATIONS ON DURATION OR THE EXCLUSION OF AN IMPLIED WARRANTY, THE ABOVE LIMITATION MAY NOT APPLY OR FULLY APPLY TO YOU.

NOTICE REGARDING PRODUCTS EQUIPPED WITH TECHNOLOGY CAPABLE OF TRACKING SATELLITE SIGNALS FROM SATELLITE BASED AUGMENTATION SYSTEMS (SBAS) (WAAS/EGNOS, AND MSAS), OMNISTAR, GPS, MODERNIZED GPS OR GLONASS SATELLITES, OR FROM IALA BEACON SOURCES: TRIMBLE IS NOT RESPONSIBLE FOR THE OPERATION OR FAILURE OF OPERATION OF ANY SATELLITE BASED POSITIONING SYSTEM OR THE AVAILABILITY OF ANY SATELLITE BASED POSITIONING SIGNALS.

Limitation or Liability

TRIMBLE'S ENTIRE LIABILITY UNDER ANY PROVISION HEREIN SHALL BE LIMITED TO THE AMOUNT PAID BY YOU FOR THE PRODUCT OR SOFTWARE LICENSE. TO THE MAXIMUM EXTENT PERMITTED BY APPLICABLE LAW, IN NO EVENT SHALL TRIMBLE OR ITS SUPPLIERS BE LIABLE FOR ANY INDIRECT, SPECIAL, INCIDENTAL OR CONSEQUENTIAL DAMAGES WHATSOEVER UNDER ANY CIRCUMSTANCE OR LEGAL THEORY RELATING IN ANY WAY TO THE PRODUCTS, SOFTWARE AND ACCOMPANYING DOCUMENTATION AND MATERIALS, (INCLUDING, WITHOUT LIMITATION, DAMAGES FOR LOSS OF BUSINESS PROFITS, BUSINESS INTERRUPTION, LOSS OF BUSINESS INFORMATION, OR ANY OTHER PECUNIARY LOSS), REGARDLESS WHETHER TRIMBLE HAS BEEN

ADVISED OF THE POSSIBILITY OF ANY SUCH LOSS AND REGARDLESS OF THE COURSE OF DEALING WHICH DEVELOPS OR HAS DEVELOPED BETWEEN YOU AND TRIMBLE. BECAUSE SOME STATES AND JURISDICTIONS DO NOT ALLOW THE EXCLUSION OR LIMITATION OF LIABILITY FOR CONSEQUENTIAL OR INCIDENTAL DAMAGES, THE ABOVE LIMITATION MAY NOT APPLY OR FULLY APPLY TO YOU.

PLEASE NOTE: THE ABOVE TRIMBLE LIMITED WARRANTY PROVISIONS WILL NOT APPLY TO PRODUCTS PURCHASED IN THOSE JURISDICTIONS (E.G., MEMBER STATES OF THE EUROPEAN ECONOMIC AREA) IN WHICH PRODUCT WARRANTIES ARE THE RESPONSIBILITY OF THE LOCAL DEALER FROM WHOM THE PRODUCTS ARE ACQUIRED. IN SUCH A CASE, PLEASE CONTACT YOUR TRIMBLE DEALER FOR APPLICABLE WARRANTY INFORMATION.

Official Language

THE OFFICIAL LANGUAGE OF THESE TERMS AND CONDITIONS IS ENGLISH. IN THE EVENT OF A CONFLICT BETWEEN ENGLISH AND OTHER LANGUAGE VERSIONS, THE ENGLISH LANGUAGE SHALL CONTROL.

Registration

To receive information regarding updates and new products, please contact your local dealer or visit the Trimble website at www.trimble.com/register. Upon registration you may select the newsletter, upgrade or new product information you desire.

Notices

This equipment has been tested and found to comply with the limits for a Class A digital device, pursuant to Part 15 of the FCC rules. These limits are designed to provide reasonable protection against harmful interference when the equipment is operated in a commercial environment. This equipment generates, uses, and can radiate radio frequency energy and, if not installed and used in accordance with the instruction manual, may cause harmful interference to radio communications. Operation of this equipment in a residential area is likely to cause harmful interference, in which case the user will be required to correct the interference at his own expense.

Properly shielded and grounded cables and connectors must be used in order to meet FCC emission limits. TRIMBLE is not responsible for any radio or television interference caused by using other than recommended cables and connectors or by unauthorized changes or modifications to this equipment. Unauthorized changes or modifications could void the user's authority to operate the equipment.

This device complies with Part 15 of the FCC rules. Operation is subject to the following two conditions: (1) this device may not cause harmful interference, and (2) this device must accept any interference received, including interference that may cause undesired operation. Responsible Party:

Trimble Navigation
935 Stewart Drive
Sunnyvale CA 94085
Telephone: 1-408 481 8000

Canada

This Class A digital apparatus complies with Canadian ICES-003. Cet appareil numérique de la classe A est conforme à la norme NMB-003 du Canada.

This apparatus complies with Canadian RSS-GEN.

Cet appareil est conforme à la norme CNR-GEN du Canada.

Europe

The product covered by this guide are intended to be used in all EU member countries, Norway, and Switzerland. Products been tested and found to comply with the requirements for a Class B device pursuant to European Council Directive 89/336/EEC on EMC, thereby satisfying the requirements for CE Marking and sale within the European Economic Area (EEA). Contains a Bluetooth radio module. These requirements are designed to provide reasonable protection against harmful interference when the equipment is operated in a residential or commercial environment. The 450 MHz (PMR) bands and 2.4 GHz are non-harmonized throughout Europe.



CE Declaration of Conformity

Hereby, Trimble Navigation, declares that the GPS receivers are in compliance with the essential requirements and other relevant provisions of Directive 1999/5/EC.

Australia and New Zealand

This product conforms with the regulatory requirements of the Australian Communications and Media Authority (ACMA) EMC framework, thus satisfying the requirements for C-Tick Marking and sale within Australia and New Zealand.



Restriction of Use of Certain Hazardous Substances in Electrical and Electronic Equipment (RoHS)

Trimble products in this guide comply in all material respects with DIRECTIVE 2002/95/EC OF THE EUROPEAN PARLIAMENT AND OF THE COUNCIL of 27 January 2003 on the restriction of the use of certain hazardous substances in electrical and electronic equipment (RoHS Directive) and Amendment 2005/618/EC filed under C(2005) 3143, with exemptions for lead in solder pursuant to Paragraph 7 of the Annex to the RoHS Directive applied.

Waste Electrical and Electronic Equipment (WEEE)

For product recycling instructions and more information, please go to www.trimble.com/ev.shtml.



Recycling in Europe: To recycle Trimble WEEE (Waste Electrical and Electronic Equipment, products that run on electrical power.), Call +31 497 53 24 30, and ask for the "WEEE Associate". Or, mail a request for recycling instructions to:

Trimble Europe BV
c/o Menlo Worldwide Logistics
Meerheide 45
5521 DZ Eersel, NL

Unlicensed radios in products

This device complies with part 15 of the FCC Rules.

Operation is subject to the following two conditions:

- (1) This device may not cause harmful interference, and
- (2) This device must accept any interference received, including interference that may cause undesired operation.

Licensed radios in products

This device complies with part 15 of the FCC Rules.

Operation is subject to the condition that this device may not cause harmful interference.

Safety Information

Always follow the instructions that accompany a Warning or Caution. The information it provides is intended to minimize the risk of personal injury and/or damage to property. In particular, observe safety instructions that are presented in the following format:



WARNING – This alert warns of a potential hazard which, if not avoided, could result in severe injury or even death.



CAUTION – This alert warns of a potential hazard or unsafe practice which, if not avoided, could result in injury or property damage or irretrievable data loss.

Note – An absence of specific alerts does not mean that there are no safety risks involved.

Warnings

Auto guidance



WARNING – Auto guidance systems cannot avoid items in the field such as obstacles. Make sure you are adequately trained to operate the auto guidance system.



WARNING – Obstacles in the field can cause collisions, which may injure you a damage the vehicle. If an obstacle in the field makes it unsafe to continue a particular phase of the Automated Deadzone calibration:

- Stop the vehicle to abort the phase.
 - Turn the steering wheel to disengage the system.
 - Reposition the vehicle and continue from the current test phase.
-



WARNING – Many large and sudden changes in satellite geometry caused by blocked satellites can cause significant position shifts. If operating under these conditions, auto-guidance systems can react abruptly. To avoid possible personal injury or damage to property under these conditions, disable the auto-guidance system and take manual control of the vehicle until conditions have cleared.



WARNING – Installers, technicians, and operators must verify that the Autopilot function (line acquisition and online guidance) is in good, safe, working order before the operator uses NextSwath.



WARNING – Do not use automated implement functions to: 1) control hazardous materials (including NH₃) or 2) operate implements near ground laborers. Failure to follow these restrictions could result in serious injury or death.

Safety Information



WARNING – A trained and qualified operator must be at the controls of the vehicle at all times, and be ready to safely take over controls of the system at anytime. NextSwath is not a safety aid nor a replacement for a skilled operator.



WARNING – NextSwath cannot avoid obstacles. The operator is solely responsible for avoiding obstacles.



WARNING – Interaction with and avoidance of boundaries is solely the operator's responsibility. While NextSwath can use field boundaries for a reference point for turn start points, the trained and qualified operator is responsible for determining offsets from field boundaries. NextSwath does not calculate distance of the vehicle or machinery from the boundary during the turn.

Calibration



WARNING – Anhydrous valve and flow calibrations require the vehicle and implement to be moving and the implement must be in the ground (the implement lift switch must be down). Take all necessary precautions to ensure user safety. Failure to do so may result in serious injury or death.



WARNING – Moving parts during this operation. Make sure that the implement is safe to operate.



WARNING – The wheels can move abruptly during the Proportional Steering Gain procedure while the Autopilot system tests the hydraulic response to the steering commands. These sudden movements can cause collisions with nearby obstacles or cause injury to occupants of the vehicle. Be prepared for sudden wheel movements.



WARNING – The steering coulters can move abruptly during the Proportional Steering Gain procedure while the TrueTracker system tests the hydraulic response to the steering commands. These sudden movements can cause collisions with nearby obstacles or cause injury. Be prepared for sudden steering coulters movements.



WARNING – The vehicle needs to move during the Hydraulic Tracked Pump Knees calibration procedure. To avoid injury, be prepared for vehicle movement.



WARNING – Obstacles in the field can cause collisions, which may injure you and damage the vehicle. If an obstacle in the field makes it unsafe to continue the Automated Deadzone calibration, stop the vehicle and turn the steering wheel to disengage the system.

- 1) Wait until the display prompts you that the phase is ready to begin.
 - 2) Look at the screen to determine whether the next phase will require a left or right turn.
 - 3) Reposition the vehicle so that the turn will use the space that you have available.
 - 4) Tap the button to begin the next phase.
-



WARNING – During the Automated Deadzone calibration, the system moves the wheels that steer the vehicle. To avoid injury, be prepared for sudden vehicle movement and that the area around the vehicle (and implement, if applicable) are clear.



WARNING – During flow calibration, the machine will become operational. Take all necessary precautions to ensure user safety. Failure to do so may result in serious injury or death.



WARNING – Material will be dispensed during calibration. Make sure that the implement is safe to operate.



WARNING – Incorrect adjustment of *Manual Override Sensitivity* could cause this critical safety feature to fail, resulting in personal injury or damage to the vehicle. Do not to choose a setting that is either too sensitive or not sensitive enough. It is vital to avoid setting the sensitivity so low that the system will not detect any steering wheel motion.

Display



WARNING – When the temperature of the display case reaches 65° C (149 ° F) the display shows the following: WARNING! HOT SURFACE, DO NOT TOUCH. The display will dim the screen until the temperature returns to normal. Use caution when touching the display when this warning is visible.

Implement master switch



WARNING – When the implement is down and the master switch is in the On position, the machine is fully operational. Take all necessary precautions to ensure user safety. Failure to do so could result in injury or death.

NH₃, anhydrous ammonia



WARNING – NH₃ is an irritant and corrosive to the skin, eyes, respiratory tract and mucous membranes, and is dangerous if not handled properly. It may cause severe burns to the eyes, lungs, and skin. Skin, and respiratory-related diseases could be aggravated by exposure. It is recommended that protective gloves, boots, slicker and/or pants and jacket, and chemical-splash goggles that are impervious to anhydrous ammonia are worn at all times.



WARNING – Anhydrous valve and flow calibrations require the vehicle and implement to be moving and the implement must be in the ground (the implement lift switch must be down). Take all necessary precautions to ensure user safety. Failure to do so may result in serious injury or death.

Cautions

Data



CAUTION – Deleting data is permanent. You cannot undo the deletion or restore the data.



CAUTION – POTENTIAL LOSS OF DATA!

If you copy files from:

- An FM-1000 Plus application to another or to an FM-1000 integrated display.
- An physical FM-1000 integrated display to another or to an FM-1000 Plus application

First make sure you have created a subfolder labeled with the display serial number for your files. Transfer your files to this subfolder. Otherwise, you will overwrite files when you copy and you will corrupt your data.



CAUTION – Do not remove the USB drive from the socket while the application is copying data. This will corrupt the data.

Display



CAUTION – Do not remove power from the display or the DCM-300 modem for 10 minutes after you tap the **Generate New** button.



CAUTION – If you leave the display powered on after shutting off the vehicle's ignition, the display power can drain the battery.

GNSS interference



CAUTION – The GNSS antenna may experience interference if you operate the vehicle within 100 m (300 ft) of any power line, radar dish, or cell phone tower.

Setup



CAUTION – Always verify implement and NextSwath settings, and verify performance for each implement you use for NextSwath. Failure to do so may result in equipment damage.



CAUTION – Some Raven controllers do not support zero rates. If the target rate is zero, and spray is still being applied, you must turn off the boom sections manually.



CAUTION – Always verify implement and NextSwath settings, and verify performance for each implement you use for NextSwath. Failure to do so may result in equipment damage.



CAUTION – You must configure the correct front/back offset. If you are using:

- An Autopilot system: Set the front/back offset to the distance from the fixed axle of the vehicle to the implement.
- Manual guidance: Set the front/back offset to the distance from the antenna centerpoint to the implement.

Touchscreen



CAUTION – Do not apply glass cleaner directly to the touchscreen.



CAUTION – Do not press on the screen with a sharp object such as a pencil. This could damage the surface of the screen.

Working with anhydrous ammonia

- Contact your NH₃ supplier to review all safety requirements associated with anhydrous ammonia (NH₃).
- Always wear correct personal protective equipment. This includes, but is not limited to:
 - Goggles or face shield
 - Protective suit and gloves
 - Respirator
- Do not allow anyone to operate the system without proper instruction and training.
- Stand up-wind when working around NH₃ and related equipment.
- Always keep NH₃ equipment away from buildings, livestock, and other people.
- Never work on NH₃ equipment in confined spaces.
- Before you attempt to transport the implement, discharge the system of all NH₃ and completely shut down the system. See [Discharging the System \(page 15\)](#).
- If symptoms of illness occur during or shortly after use of NH₃ products, seek immediate medical attention.
- Keep a source of clean water (at least five gallons) readily available. In case of exposure, flush exposed skin or eyes immediately with large quantities of water and seek immediate medical attention.
- NH₃ can be harmful to the environment if not used correctly. Follow all local, state, and federal regulations regarding proper handling of this chemical.

Servicing the Equipment

1. Remove the system from operation before performing any maintenance.
2. Thoroughly bleed all system lines and disconnect the nurse tank hose. See [Discharging the System \(page 15\)](#).
3. Make sure that the gauge pressure is at zero before you open the system.
4. Use extreme caution when opening a previously pressurized system.

Discharging the System

1. Turn off the console or vehicle master switch.
2. Completely close the main shut-off valve on the supply or nurse tank.
3. Resume field application until the pressure gauge shows zero pressure.
4. Check again that the console and/or vehicle master switch, and all section switches, are turned off.
5. Completely close the emergency shut-off valve the cooling tower.
6. Bleed and disconnect the nurse tank supply hose from the system.
7. Turn on the console master switch and all section switches.
8. Stand up-wind from the implement and then slowly open the bleed valve(s) until fully open.
9. Allow at least one (1) hour for the system to fully discharge.
10. Before you open the system, make sure that the pressure gauge on the manifold reads zero and that the cooling tower is not cold to the touch. This ensures that all liquid NH₃ has evaporated and that the pressure is discharged.

Note – Frost on any component is a positive indication of trapped NH₃ at low pressure. Lack of frost does not always indicate a lack of NH₃.

Contents

Safety Information	10
Warnings	10
Cautions	13
Working with anhydrous ammonia	14
1 Introduction	29
About the FM-1000 Plus application	30
Optional features	30
Compatibility	30
Installation	31
Supported features	31
Changes to this document	32
2 FM-1000 Plus application basics	33
Display power on/off	34
Automatic power on	34
Manual power on	34
Automatic power off	34
Manual power off	35
Touch screen basics	36
Interactive controls	36
Cleaning the touch screen	37
Main screens	38
Launcher screen	39
Interruption of services	39
Application menu button	39
Home screen	40
Configuration Selection screen	41
Field Selection screen	43
Configuration screen	44
Run screen	45
On-screen user guide	46
System bar	47
Navigation buttons	47
Emergency button	47
Screenshot	47
Optional features/plugins	48
Vehicle guidance	48
Features for application	48
ISOBUS	48
Implement control	49
Connectivity	49

Contents

Water Management	49
Harvest	49
Screen shots	50
FM-1000 Plus application Passwords	51
Access password	51
Change administration password	51
3 Basic settings	53
Settings	54
FM-1000 Plus application-specific settings	54
FM-1000 Plus application and display settings	54
Display-specific settings	54
Upgrades and unlocks	55
Unlocks and upgrades	56
Firmware upgrades	56
USB upgrades	56
Wireless upgrades	57
Feature unlocks	59
Manual code entry	59
QR code scan	59
Check for unlocks	59
Activate features/plugins for use	60
FM-1000 Plus application settings	61
Data dictionary	62
Data Files	63
EZ-Remote Joystick	64
Field feature mapping settings	65
Guidance settings	66
Language, measurements, keyboard layout	67
Lightbar settings	68
Map settings	70
Port settings	74
Configuration principles	75
Restore default settings	76
Signal input module for OEM switch	77
Sounds	78
Status items	79
Display settings	91
Access display settings	91
Shortcut	91
Launcher screen	91
Date and time settings	91
Languages and units settings for display	92
Users and passwords	93

Add a user	93
Take a photo of a user	93
Wi-Fi settings	94
Restore defaults	94
Admin User Options	94
4 Data management	95
Managing data	96
Transfer data	96
Data Files screen	96
Delete data	99
Data storage structure	101
AB Lines folder	101
Archives folder	102
Autopilot folder	102
Data folder	102
Data Dictionary folder	109
Diagnostics folder	109
Prescriptions folder	110
Summaries folder	110
Task Data folder	112
Data Dictionary categories	112
Default data entry categories	112
Edit data entry categories	112
Create / load a data dictionary	113
5 Connectivity settings	115
GPS receiver settings	116
AgRemote Interface	117
Basic correction settings	118
CenterPoint RTK	119
CenterPoint RTX US or EU (fs)	121
CenterPoint RTX (sc)	123
CenterPoint RTX (ss)	124
OmniSTAR HP/XP/G2 - VBS	126
OmniSTAR HP/XP/G2	128
OmniSTAR VBS	130
RangePoint RTX	131
Frequencies and baud rate	132
GPS output settings	133
CAN GPS messages	133
Serial NMEA messages	134
NMEA messages	135
Remote Output setup	136

Contents

Remote Output settings	136
Calibrate implement lead time	139
Serial Data Input	142
Ag3000 modem	143
Modem activation	143
Modem setup	143
DCM-300 Modem	144
Unlock the modem	144
Service activation	144
Modem setup	145
6 Field feature mapping setup	147
Field feature mapping settings	148
Access Feature Mapping settings	148
Assign feature buttons	148
Create a field feature	149
Edit a field feature	149
Mapping location setting	150
Recording with coverage	151
Field area feature settings	151
Line feature settings	152
Boundary feature settings	152
Point feature settings	154
7 Implement setup	155
Implement setup	156
Create an implement	157
Select an implement	157
Import an implement	158
Edit implement settings	158
Implement Type	158
Measurements	159
Geometry	159
Overlap	160
Switches	160
Delete an implement	160
8 Vehicle guidance setup	161
Guidance settings	162
Manual guidance	162
Autopilot system	164
Begin setup	164
Autopilot calibration	169
Row Guidance	185

Save vehicle profile	186
OnSwath settings	188
NextSwath settings	189
Requirements	189
Restrictions	190
Automatic turn settings	190
Automated headlands management settings	194
EZ-Pilot assisted steering system	199
Vehicle settings for EZ-Pilot system	199
Steering settings for EZ-Pilot system	200
Engage settings for EZ-Pilot system	201
EZ-Pilot system calibration	202
EZ-Steer assisted steering system	205
Engage settings for EZ-Steer	206
Advanced settings for EZ-Pilot	206
EZ-Steer system calibration	208
9 Field-IQ system setup	211
Field-IQ system functionality	212
Pressure limiting	214
Flow control	214
Pressure limiting	214
Setup	215
General setup information	215
Implement setup for Field-IQ	215
Field-IQ system setup	218
Material setup	219
Alarms tab	219
Operation tab	220
Coefficient tab	221
Control setup	222
Material tab	222
Layout	224
Section Control tab	225
Material linking	226
Automatic Section Control	227
Rate Control tab	230
Rate control module setup	232
Section Widths screen	232
Drive Setup screen	233
Row monitoring	237
Sensor tab	237
Equipment calibration for Field-IQ	239
Air Seeder calibration	239

Contents

Anhydrous calibration	240
Planter calibration	242
Sprayer calibration	246
Spreader calibration	251
10 GreenSeeker setup	257
GreenSeeker functionality	258
Care and maintenance	258
Field preparations for nitrogen application	259
Field setup	260
Field preparations for user defined rate	261
Field calibration	261
Delivery system and liquid control	261
Select a nozzle	262
11 ISOBUS setup	263
ISOBUS settings	264
Virtual Terminal setup	264
Task Controller setup	264
GPS output settings	265
Equipment setup	266
12 Serial Rate Control setup	269
Supported variable rate controllers	270
Variable rate controller setup	271
Amazone Amatron +	272
Bogballe Calibrator	272
Flex-Air setup	272
Hardi 5500 and 6500	273
LH5000	274
Raven	274
Rawson and New Leader	276
Vaderstad Control Station	277
Additional controller setup	277
Alarms	278
Coverage mapping	278
Prescriptions	278
Target and applied rates	278
Units	278
13 TrueGuide setup	279
TrueGuide system	280
Benefits	280
Requirements	280

Implement setup and selection	281
TrueGuide setup	282
System aggressiveness settings	282
TrueGuide calibration	283
14 TrueTracker setup	285
TrueTracker	286
Requirements	286
Setup process	287
Implement controller setup for TrueTracker system	287
Vehicle settings for TrueTracker system	288
Engage settings for TrueTracker system	290
Steering settings for TrueTracker system	291
Implement calibration for TrueTracker system	292
Controller orientation setup	292
Proportional Steering Gain calibration	292
Implement Steering Sensor calibration	294
Implement Automated Deadzone calibration	295
Antenna position and roll offset correction	296
Line Acquisition Aggressiveness calibration	299
15 Vehicle Sync setup	301
Vehicle Sync	302
Requirements	302
Setup steps	302
16 Water Management setup	305
Water Management features	306
Requirements	306
FieldLevel II Survey/Design	307
Benchmarks	307
Rebenching	307
Settings	307
FieldLevel II Leveling	310
Requirements	310
Setup process	310
Leveling models	311
Implement settings for FieldLevel II	311
GPS receiver setup	311
FieldLevel II settings	312
Valve module calibration	316
Tandem / dual scraper setup	317
Tandem scraper	317
Dual scraper	317

Contents

Set up	317
Implement setup	318
Prepare connections	318
Primary receiver setup	318
Secondary receiver setup	318
Tandem / Dual settings	318
Tandem / dual calibration	319
WM-Drain setup	320
Implement control settings	321
Valve settings	323
Limit and increment settings	323
Relative heights settings	324
Operation settings	324
Calibrate WM-Drain for cantilever plow	326
Calibrate the valve	330
17 Yield Monitoring setup	331
Yield Monitoring functionality	332
Yield Monitoring best practices	333
Installation	333
Tare calibration	333
Flow calibration	334
Pitch/Roll calibration	334
Test weight	335
Calibrating and operating conditions	335
Yield Monitoring settings	336
Before setup	336
Setup steps	336
Yield sensor / moisture sensor calibration	340
Calibration steps	340
Speed method	341
Cut width method	342
Third-party display instructions	343
Claas Cebis Quantimeter setup	343
Claas Cebis Quantimeter calibration	344
Claas Cebis Auto Pilot calibration	345
Greenstar Monitor: Stop Head Height setup	345
Greenstar Monitor calibrations	346
Command Center (70 Series Combines)	347
18 Operations	351
Operations overview	352
Operation basics	352
Main buttons	353

Feature panels	356
Engage button	359
Coverage button for logging	360
GNSS status	360
On-screen lightbar for vehicle	360
On-screen lightbar for implement	360
Fields	361
Field creation / selection	361
Implement selection	362
Vehicle selection	363
Event summary adjustment	363
Close a field	363
Field feature use	364
Add field features	364
Guidance pattern use	365
Creating patterns	365
Access paths	365
Existing patterns	365
Guidance mapping controls	366
Swaths Management screen	367
Straight guidance pattern	369
Curved pattern	371
Headland pattern	372
Pivot pattern	374
FreeForm pattern	376
Pause recording	377
Access paths	379
Switch to the next pattern	380
Import AB Lines or boundaries	380
Load a pattern	381
Rename a swath	381
Delete a swath	383
Switch to the next pattern	383
Shift a swath	383
Skip a swath	385
Coverage logging	386
Field-IQ operation	389
Field-IQ panel	390
Field-IQ master switch box functions	394
Field-IQ 12-section switch box (optional)	396
Material assignment	396
Enable sections	397
Prescriptions	398
Manual guidance operation	401

Contents

Autopilot system operation	402
Adjust Autopilot guidance	403
Disengage Autopilot system	404
NextSwath operation	405
Automatic turn	406
Auto turn cancel	409
Adjust direction and swath number	410
Start turn now	411
Yellow turn button	411
Red turn button	411
Green turn button	412
TrueSwath operation	413
Using automated headlands management	415
EZ-Pilot system operation	416
Disengage EZ-Pilot system	417
Adjust EZ-Pilot guidance	418
EZ-Steer system operation	419
Disengage EZ-Steer system	420
Adjust EZ-Steer guidance	421
GreenSeeker operation	422
Best practice	422
Variable rate setup	423
Create a custom table	423
Calibrate GreenSeeker	424
ISOBUS operation	427
Task Controller operation	427
Virtual Terminal operation	428
Remote Output operation	429
Crossing a line feature operation	429
Distance-based pulse operation	431
Within range limits	431
Outside range limits	432
Change trigger limits during operation	432
Manually output a pulse	432
Row Guidance operation	433
Use row sensors	434
Shift or skip guidance line	435
Row Guidance adjustments	436
TrueGuide operation	437
Using TrueGuide	438
TrueTracker operation	439
TrueTracker controls	439
Implement status	440
Implement on-screen lightbar	440

Vehicle Sync operation	442
Common uses	442
Benefits	442
Using Vehicle Sync	442
Guidance lines with Vehicle Sync	443
Coverage	444
Water Management functionality	446
Create a survey	446
Design	448
Leveling	450
WM-Drain operation	464
Survey tab	465
Install tab	466
Design tab	467
Design screen	468
Set survey height offset	473
Create a tile / ditch survey line	474
Design a section line	474
Add a fixed point	477
Clip a portion of a section line	477
Installation/ditch cleaning	478
Define boot depth	481
Yield Monitoring operation	482
Yield Monitoring panel	482
Variety tracking	483
Load tracking	484
19 Diagnostics	485
System diagnostics	486
Advanced system diagnostics	486
CAN Bus data	487
Configuration data	487
Network diagnostics	487
Serial Comms	487
Autopilot diagnostics	488
Controls	488
Guidance tab	489
Steering tab	489
Details tab	490
Autopilot Faults screen	490
Warning screen	490
EZ-Pilot diagnostics	490
EZ-Steer diagnostics	491
Field-IQ diagnostics	492

Contents

Operations tab	492
Hardware tab	493
Row Monitor tab	493
Field-IQ faults and troubleshooting	494
FieldLevel II diagnostics valve test	514
GPS status	514
GreenSeeker diagnostics	514
Incorrect data	515
Error conditions	515
Row-Guidance diagnostics	515
Vehicle Sync diagnostics	517
Yield Monitoring diagnostics	518
Status tab	518
Yield Monitor error messages	519
Yield Monitor troubleshooting	521
Yield Monitoring warning messages	522
20 Glossary	527
A	527
B	527
C	528
D	529
E	530
F	530
G	530
H	531
I	531
L	531
M	532
N	532
O	533
P	533
R	533
S	534
T	535
V	535
W	535

Introduction

In this chapter:

About the FM-1000 Plus application	30
Changes to this document	32

This user guide includes information on setting up and using the FM-1000™ Plus application. For installation information, see *XCN-2050 Cabling Guide*.

About the FM-1000 Plus application

With the FM-1000™ Plus application, you can perform:

- Field definition and mapping
- Feature mapping
- Guidance to predefined field patterns
- Logging of coverage data
- Variable rate control
- Boom/Row switching
- Logging of topographic mapping data
- Output of information for analysis in office-based Geographic Information System (GIS) software
- Seed, Liquid, Granular, and Anhydrous Ammonia control
- Seed monitoring

Optional features

The FM-1000 Plus application has a number of optional features /plugins you can install to expand its functionality.

Most of these features require additional hardware. For installation information, see the *XCN-2050 Cabling Guide*.

Note – Some configuration settings are unavailable when a field is open in the Run screen. To access these settings, return to the Run screen and then tap the Home button. When prompted to close the field, tap **Yes**.

Also see [Optional features/plugins \(page 48\)](#), [Feature unlocks \(page 59\)](#) and [Activate features/plugins for use \(page 60\)](#).

Compatibility

The following are compatible with the FM-1000 Plus application:

- Trimble Autopilot™ automated steering system
- Trimble EZ-Steer® assisted steering system
- Trimble EZ-Pilot® steering system
- Trimble TrueTracker™ implement steering system
- Trimble TrueGuide™ implement guidance system
- Trimble FieldLevel™ II

- Trimble WM-Drain[®] farm drainage system
- Trimble Rawson[™] drive
- Trimble Field-IQ[™] crop input control system
- Trimble RangePoint[™] RTX[™]
- Trimble CenterPoint[™] RTX and CenterPoint VRS[™]
- Trimble VRSNow[™]
- Trimble Farm Works Software[®]
- Trimble GreenSeeker[®]
- Trimble Tru Count Air Clutch[®]
- Trimble AutoSense[™]
- Trimble T2[™] terrain compensation technology
- Trimble T3[™] roll compensation
- OmniSTAR[®] wide-area differential GPS service
- Trimble NextSwath[™] end of row turn technology

Installation

To install the display and required cabling for your configuration, see the *XCN-2050 Cabling Guide*.

Supported features

All features available in the FM-1000[™] display are available in the 1.0 version of the FM-1000 Plus application except:

- Remote Assistant
- External speakers for the Trimble EZ-Pilot[®] system and EZ-Steer[®] assisted steering system

Productivity and Delay and cameras are separate applications that you can access from the [Launcher screen \(page 39\)](#).

Changes to this document

The changes for this document for the FM-1000 Plus application version 3.0, revision A are:

- Remote Output: Crossing a Line Feature has been added. See [Remote Output settings \(page 136\)](#) and [Remote Output operation \(page 429\)](#).
- WM Drain: Changes to the *Run* screen and added features, including clipping/deleting a section line and adding fixed points during design. See [WM-Drain operation \(page 464\)](#).
- Serial NMEA messages: 10 Hz has been added as an output. See [Serial NMEA messages \(page 134\)](#).
- The addition of pressure limiting to Field-IQ. See [Pressure limiting \(page 214\)](#).
- The addition of CenterPoint RTX fast satellite for Europe. See [CenterPoint RTX US or EU \(fs\) \(page 121\)](#).

FM-1000 Plus application basics

In this chapter:

Display power on/off	34
Touch screen basics	36
Main screens	38
On-screen user guide	46
System bar	47
Optional features/plugins	48
Screen shots	50
FM-1000 Plus application Passwords	51

The FM-1000 Plus application has five main screens you use for setup and operations. You can also access on-screen help.

Optional features (plugins) are available to add to the FM-1000 Plus application.

Display power on/off

Note – The display must be correctly installed **before** powering on. For more information, see XCN-2050 Cabling Guide.



CAUTION – If you leave the display powered on after shutting off the vehicle's ignition, the display power can drain the battery.

Automatic power on

If the display is connected to the ignition source, power on the vehicle. The TM-200 Module sends power to the display when the vehicle powers on. The display powers on. After a short pause, the [Launcher screen \(page 39\)](#) displays.

To open the FM-1000 Plus application, tap .

Note – After you have initially powered on the display, the FM-1000 Plus application may not open until the TM-200 Module has initialized or finished booting.

Manual power on

To turn on the display manually, hold the power button down briefly (about half a second). The power button is on the rear of the display.

The display powers on. After a short pause, the [Launcher screen \(page 39\)](#) displays.

To open the FM-1000 Plus application, tap .

Note – After you have initially powered on the display, the FM-1000 Plus application may not open until the TM-200 Module has initialized or finished booting.

Automatic power off

If the display is connected to the ignition source, when you switch the ignition off, a shutdown/reboot dialog displays. If you do nothing the display shuts off in 60 seconds. If you choose not to shutdown the display, it will remain powered on indefinitely.

Note – If you fail to close FM-1000 Plus application before power down, you may experience a loss of data.



CAUTION – If you leave the display powered on after shutting off the vehicle's ignition, the display power can drain the battery.

Manual power off

To manually turn the power off, hold the power down button for one to two seconds. See the steps below.

1. Close the FM-1000 Plus application.
2. Turn off the display manually by holding the power button down for about two seconds.
3. Choose one of the following options:
 - Shutdown: Powers down the display
 - Reboot: Restarts the display
 - Cancel: Cancels the power off process

Note – *If you fail to close FM-1000 Plus application before rebooting or shutdown, you may experience a loss of data.*

Note – *Sometimes after you press the power button and tap **Shutdown**, the display does not immediately turnoff. This is because the FM-1000 Plus application is saving settings. The display will power off after all settings are saved.*

If these steps do not cause the power to go off, you can force a shut down of the display by holding the power button for 5 seconds.

Touch screen basics



If you are unfamiliar with using a touch screen, this section contains the basics of using a touch screen and how to clean it.

Interactive controls

Use your fingers to interact with buttons, maps, lists and selectors.



CAUTION – Do not press on the screen with a sharp object such as a pencil. This could damage the surface of the screen.

Item	Action	Explanation
Buttons and selectors	Tapping 	<i>Tap</i> means to touch a point on the screen and then remove your finger from the screen. A <i>tap</i> is a single touch. You do not move your finger while touching the screen. You tap buttons, items in lists, points on a range, and so on.
Lists	Scrolling 	When a list has more items than fit on a screen or in a box, you can move the list to see all items by scrolling up, down, or side to side. To scroll: <ol style="list-style-type: none"> 1. Touch anywhere on the scroll bar and hold your finger on the it. 2. Move your finger in the direction that you want to move the up or down. 3. Remove your finger when you are satisfied with the position of the list.
Settings shortcut	Swiping down 	Swipe down on the upper right area of the screen to quickly access the brightness control and Display settings. See Access display settings (page 91) .

Cleaning the touch screen



CAUTION – Do not press on the screen with a sharp object such as a pencil. This could damage the surface of the screen.

Use the following supplies to clean the touch screen of the display:

- Ammonia-free glass cleaner
- Soft, lint-free cotton cloth
- 50% isopropyl alcohol



CAUTION – Do not apply glass cleaner directly to the touchscreen.

1. Apply a small amount of ammonia-free glass cleaner to the cloth.
2. Gently rub the touchscreen with the cloth.
3. To remove stains or smudges, use a cotton cloth dampened with 50% isopropyl alcohol.



Tip – You can set up status items to show the length of the swath (Swath Length) and the calculated distance to the end of the swath (Along Track Error). See [Status items \(page 79\)](#).

Main screens

The FM-1000 Plus application has the following main screens:

- [Launcher screen \(page 39\)](#): The first screen that displays when you power on the display
- [Home screen \(page 40\)](#): The first screen that displays when you open FM-1000 Plus application
- [Run screen \(page 45\)](#): For performing operations
- [Configuration Selection screen \(page 41\)](#): For switching and editing selections for system, vehicle and implement
- [Configuration screen \(page 44\)](#) (and subsequent setup screens): For setting up the system and features
- [Field Selection screen \(page 43\)](#): For choosing which field to work in
- [On-screen user guide \(page 46\)](#): For viewing immediate help about a screen

Launcher screen



You open applications from the Launcher screen by tapping them, including:

- FM-1000 Plus application
- XCN-2050™ application
- Connected Farm™ applications
- Dealer-specific applications

The FM-1000 Plus application and XCN-2050 application cannot be open at the same time. If you are switching from FM-1000 Plus application to XCN-2050 application or XCN-2050 application to FM-1000 Plus application:

1. Close the FM-1000 Plus application by navigating to the *Home* screen and tapping **Close**.
Note – If you fail to close FM-1000 Plus application before rebooting, you may experience a loss of data.
2. Reboot the display by holding down the power button for 1-2 seconds.
3. When the option menu displays, tap **Reboot**.

Interruption of services

If automatic steering, spraying, seeding or other services are engaged in FM-1000 Plus application and you go to the Launcher screen, the automatic systems will disengage.

Application menu button

To see all the application icons on the Launcher screen, tap the application menu button .

Home screen

The *Home* screen lists the following information about the configuration:

- The display build date, firmware and hardware version
- All optional features/plugins loaded on the application
- The automatic steering system (if applicable)
- The GPS receiver version, correction source and subscription information
- The selected vehicle make and model

The *Home* screen has two tabs:

- Home tab, containing the buttons:
 - **Open Field:** Tap to open the [Configuration Selection screen \(page 41\)](#).
 - **Settings:** Tap to open the [Configuration screen \(page 44\)](#).
 - **Data Transfer:** Tap to display the Data Transfer screen. See [Transfer data \(page 96\)](#).
 - **Modules:** Tap to upgrade hardware modules.
- System Information tab, listing about the configuration:
 - Display firmware build date, firmware, and hardware version
 - Optional features/plugins loaded on the application
 - Vehicle and implement automatic steering controller version, date, and serial number (if applicable)
 - GPS receiver version, correction source, and subscription information
 - Selected vehicle make and model

Configuration Selection screen

Before you enter the *Run* screen, the *Configuration Selection* screen shows the current configuration selected for the:

- System
- Vehicle
- Implement

Access the *Configuration Selection* screen from the *Home* screen.



For each of these you can:

- Switch to another system, vehicle or implement
- Edit settings

The *Configuration Selection* screen shows the current configuration selected for the:

- System
- Vehicle
- Implement

System configuration switching

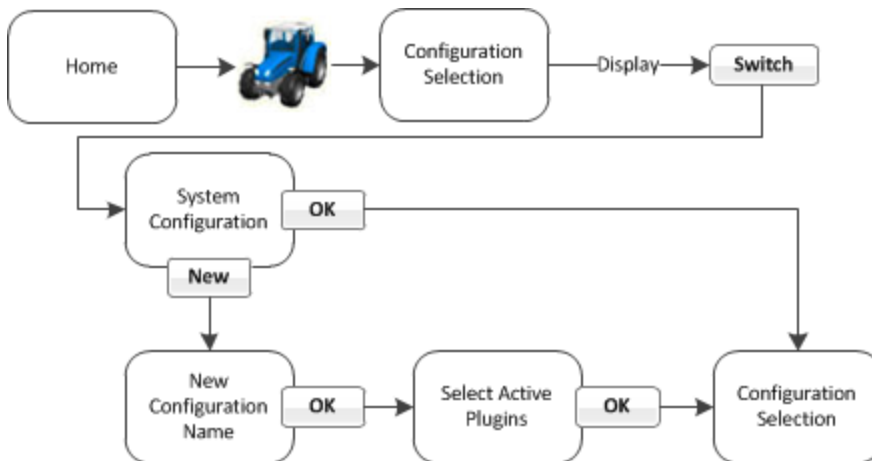

Vehicle configuration switching

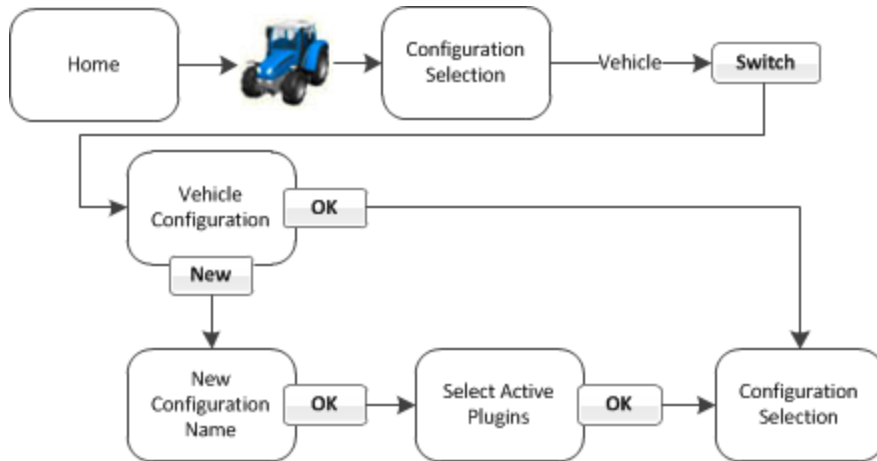

Implement configuration switching

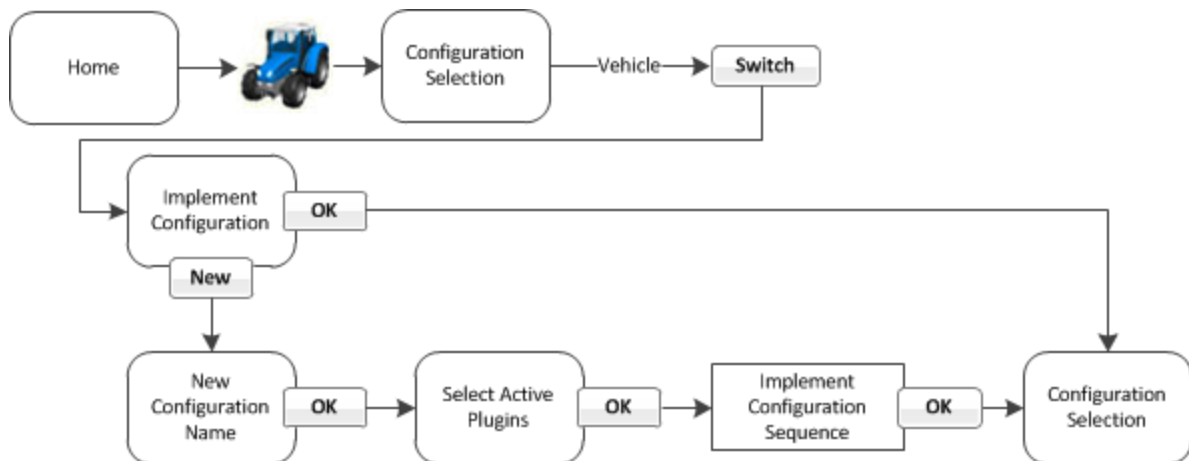

Field Selection screen

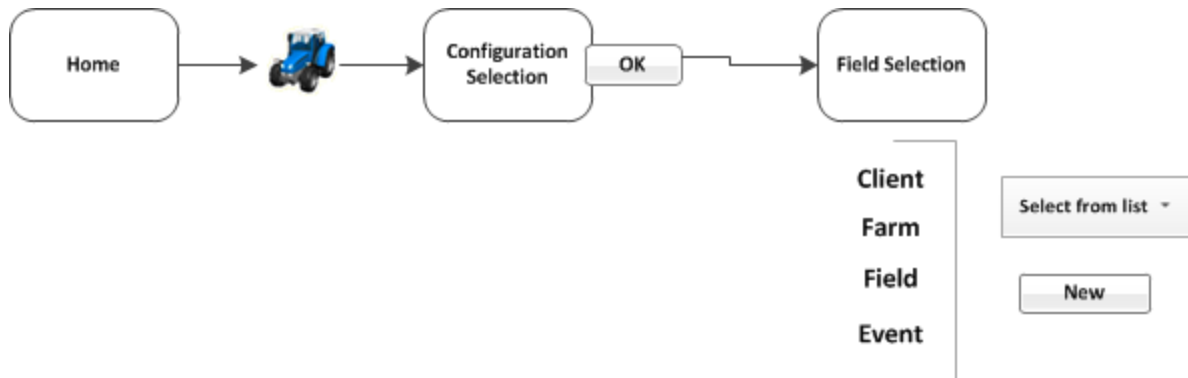



1. When you want to go to a field to begin work in the *Run* screen, tap  at the *Home* screen.
2. If the system, vehicle and implement at the *Configuration Screen* are what you want to use, tap **OK**.
3. At the *Field Selection* screen, you can:
 - Choose existing fields you have created in the system
 - Create a new field (as well as the client, farm and event associated with it)

For more information, see [Field creation / selection \(page 361\)](#).

Configuration screen

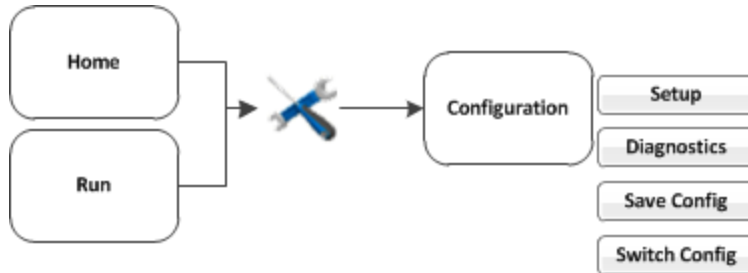
You can access the *Configuration* screen from the *Home* or *Run* screen.



Note – Some configuration settings are unavailable when a field is open in the *Run* screen. To access these settings, return to the *Run* screen and then tap . When prompted to close the field, tap **Close**. Then tap  to access the *Configuration* screen.

For each item shown in the configuration list on the *Configuration* screen, you can:

- Change settings
- View diagnostics
- Save the configuration
- Switch the selected configuration

You can also add or remove features/plugins to perform different operations. See [Activate features/plugins for use \(page 60\)](#).



Run screen

You access the *Run* screen from the *Home* screen.



You can also move between the *Run* screen and the *Configuration* screen in some cases.

The *Run* screen is used during operations and shows your guidance lines and an on-screen representation of your vehicle in the field. The areas of the *Run* screen include:

- [Operational view \(page 355\)](#)
- [Main buttons \(page 353\)](#)
- [On-screen lightbar for vehicle \(page 360\)](#)
- [Optional features/plugins \(page 48\)](#)
- Coverage button and information. See [Coverage button for logging \(page 360\)](#).
- [Engage button \(page 359\)](#) , if applicable

You can navigate from the *Run* screen to the *Configuration* screen to:

- Change settings
- View diagnostics
- Save configuration (in some cases)

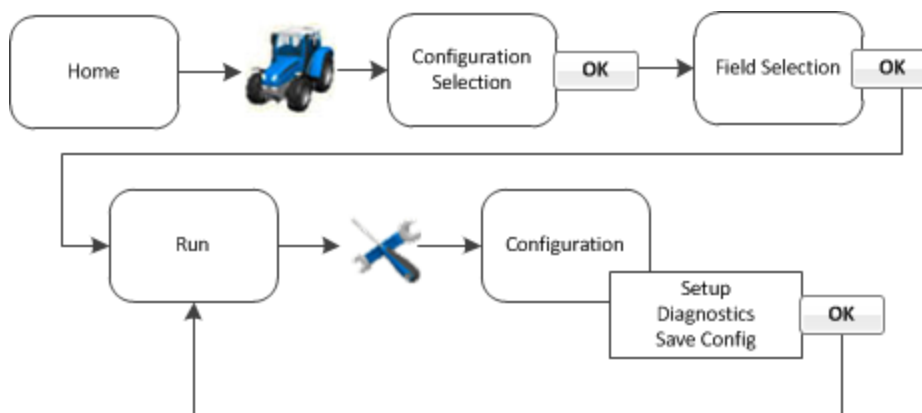

On-screen user guide

To access the on-screen user guide for the FM-1000 Plus application:

1. Close the FM-1000 Plus application by navigating to the *Home* screen and tapping **Close**.

Note – *If you fail to close FM-1000 Plus application before rebooting, you may experience a loss of data.*

2. Go to the [Launcher screen \(page 39\)](#).

3. Tap .

Note – *If automatic steering, spraying, seeding or other services are engaged in FM-1000 Plus application and you go to the Launcher screen without closing the FM-1000 Plus application, the automatic systems will disengage.*

System bar



CAUTION – Do not press on the screen with a sharp object such as a pencil. This could damage the surface of the screen.



The system bar is always available at the bottom of the screen on the FM-1000 Plus application.



Navigation buttons

Navigation buttons in the middle of the bottom display bar enable you to navigate between views.



Button	Tap to...
	Go to the Home screen (page 40) .
	Go to the Launcher screen (page 39) .
	See all views. Tap the view you want to fill the screen.

Emergency button

In the middle of the bottom bar, the Emergency button is displayed at all times. To cancel all functions controlled by the display, tap . This button is useful if you need to quickly disengage an automatic steering system or end application control.

Note – Tapping this button does not turn the vehicle off or stop it. It only cancels display-controlled functions such as automatic steering systems, spraying, seeding and so on.

Screenshot

To capture a screen, tap the camera button  on the far right of the bottom display bar. See [Screen shots \(page 50\)](#).

Optional features/plugins

The FM-1000 Plus application has a number of optional features (plugins) you can install to expand its functionality. Most of these features require additional hardware. You must:

1. Purchase the feature.
2. Install any hardware required by the feature.
3. Unlock the feature. See [Feature unlocks \(page 59\)](#).
4. Activate the feature for use. See [Activate features/plugins for use \(page 60\)](#).
5. Configure the feature.

Vehicle guidance

- Trimble Autopilot™ automated steering system: See [Autopilot system \(page 164\)](#).
- Trimble EZ-Pilot™ assisted steering system: See [EZ-Pilot assisted steering system \(page 199\)](#).
- Trimble EZ-Steer® assisted steering system: See [EZ-Steer assisted steering system \(page 205\)](#).
- RG-100 Row Guidance system: Works with the Autopilot system to center the combine on the rows. See [Row Guidance \(page 185\)](#).

Features for application

- Trimble Field-IQ™ crop input control system: Control sections and vary application rates. See [Field-IQ system setup \(page 218\)](#) and [Field-IQ operation \(page 389\)](#).
- GreenSeeker®: Vary fertilizer rate in real-time using crop vigor measurements. See [GreenSeeker functionality \(page 258\)](#) and [GreenSeeker operation \(page 422\)](#).
- Serial Rate Controller: Use a variable rate controller. See [Additional controller setup \(page 277\)](#).

ISOBUS

- Virtual Terminal: View and use Virtual Terminal. See [Virtual Terminal setup \(page 264\)](#) and [Virtual Terminal operation \(page 428\)](#).
- Task Controller: Use Task Controller. See [Task Controller setup \(page 264\)](#) and [Task Controller operation \(page 427\)](#).

Implement control

- Trimble TrueGuide™ implement guidance system: Use guidance on the implement for greater accuracy. See [TrueGuide system \(page 280\)](#) and [TrueGuide operation \(page 437\)](#).
- Trimble TrueTracker™ implement steering system: Automatically steer the implement for greater accuracy. See [TrueTracker \(page 286\)](#) and [TrueTracker operation \(page 439\)](#).

Connectivity

- Ag3000 modem: Receive cellular RTK corrections. See [Ag3000 modem \(page 143\)](#).
- DCM-300 modem: Receive RTK corrections from a VRS™ network, a third-party RTK provider or a CORS. See [DCM-300 Modem \(page 144\)](#).
- Vehicle Sync: Transmit data between vehicles. See [Vehicle Sync \(page 302\)](#).
- Serial Data Input: Enable data input from an external serial device. See [Serial Data Input \(page 142\)](#).
- Remote Output: Enable remote data output to an external device. See [Remote Output setup \(page 136\)](#).
- EZ-Remote™ Joystick: Control a variety of FM-1000 Plus application functions remotely. See [EZ-Remote Joystick \(page 64\)](#).

Water Management

- Survey and design: Survey a field and then create a design. See [Survey the field \(page 447\)](#) and [Create / save a design \(page 449\)](#).
- FieldLevel™ II:
 - Level the field to a design, install subsurface drainage or surface ditches. See [FieldLevel II Leveling \(page 310\)](#).
 - Control leveling with two GPS receivers, in one of two possible scraper configurations. See [Tandem / dual scraper setup \(page 317\)](#), [Dual scraper controls \(page 462\)](#), and [Tandem scraper controls \(page 463\)](#).
- WM-Drain® farm drainage solution: For subsurface drainage. See [WM-Drain setup \(page 320\)](#) and [WM-Drain operation \(page 464\)](#).

Harvest

- Yield Monitoring: Display yield monitoring data. See [Yield Monitoring settings \(page 336\)](#) and [Yield Monitoring operation \(page 482\)](#).

Screen shots

To save an image of the FM-1000 Plus application screen, tap  on the bottom left of the screen.

The screenshot is stored:

- On the USB drive under Pictures \ Screenshots
- In the Data Dictionary under Diagnostics \ Screenshots

FM-1000 Plus application Passwords

The access and administration passwords apply to the FM-1000 Plus application.

Access password

Any **Setup** or **Calibrate** button marked with a padlock icon  is protected by two passwords:

- Administration password: Your password.
- Master password: A backup password in case you lose the Administration password. If you need the Master password, contact your local reseller.

The password screen displays the first time that you tap a **Setup** or **Calibrate** button after you turn on the FM-1000 Plus application. Use the on-screen keyboard to enter the administration password and then tap **OK**.

Note – Passwords are case sensitive.

Change administration password

Note – To change the Administration password, you need the Master password. If you do not know it, contact your local reseller.

1. If you have not entered the password during the current session, at the *Configuration* screen tap **Setup** or **Calibrate**.
2. If you have already entered the password during this session, tap button and then tap **Lock Configuration**. On the *Configuration* screen tap **Setup** or **Calibrate**.
3. The *Enter Administration Password* screen displays.
4. Enter an incorrect password. The *Wrong Password* screen displays.
5. Tap **Enter Master Password**.
6. Enter the master password and then tap **OK**. The *Change Administration Password* screen displays.
7. Enter your new administration password in both fields. The new administration password is now active.

Basic settings

In this chapter:

Settings	54
Unlocks and upgrades	56
Activate features/plugins for use	60
FM-1000 Plus application settings	61
Display settings	91
Access display settings	91
Date and time settings	91
Languages and units settings for display ...	92
Users and passwords	93
Wi-Fi settings	94
Restore defaults	94

Basic settings include:

- **Upgrades:** Upgrading the system firmware or features you have purchased and activated
- **Unlocks:** Features you purchase are included with a passcode so that you can unlock them on your system.
- **Activation for use:** After you have unlocked a feature, you can activate it for use for your operation. You can also deactivate features in order to activate other features for use.

Settings

You can customize and set up many options for both the FM-1000 Plus application and the XCN-2050 display.

FM-1000 Plus application-specific settings

Some settings are specific to the FM-1000 Plus application only:

- [Data dictionary \(page 62\)](#)
- [EZ-Remote Joystick \(page 64\)](#)
- [Field feature mapping settings \(page 65\)](#)
- [Guidance settings \(page 66\)](#)
- [Language, measurements, keyboard layout \(page 67\)](#)
- [Lightbar settings \(page 68\)](#)
- [Map settings \(page 70\)](#)
- [Restore default settings \(page 76\)](#)
- [Signal input module for OEM switch \(page 77\)](#)
- [Sounds \(page 78\)](#)
- [Status items \(page 79\)](#)

FM-1000 Plus application and display settings

Some settings affect both FM-1000 Plus application and the display, including the Launcher screen:

- [Languages and units settings for display \(page 92\)](#)
- [Date and time settings \(page 91\)](#)
- [Users and passwords \(page 93\)](#)
- [Restore defaults \(page 94\)](#)
- [Wi-Fi settings \(page 94\)](#)

Display-specific settings

Settings in [Display settings \(page 91\)](#) affect the volume, brightness and sounds from the display.

Upgrades and unlocks

Navigate to these settings to upgrade firmware or unlock features:

- [Firmware upgrades \(page 56\)](#)
- [Feature unlocks \(page 59\)](#)

Unlocks and upgrades

Unlocks are passcodes you enter to activate a feature or service on the display after you have purchase it.

Upgrades are firmware updates to the existing firmware or feature that you have already activated.

Note – If you are using the XCN-2050 display for the first time, you must first obtain a GPS position for unlocks to become active. If the display was installed indoors, you must move the equipment with the display outside to gain satellite access.

Firmware upgrades

You can upgrade firmware using a USB drive or wirelessly if your configuration includes a DCM-300 modem, subscription to Office Sync and Wi-Fi or data plan.

USB upgrades

Note – Do NOT shut down the system during upgrades. The upgrade process can take at least 10 minutes, depending on your system's configuration. The system will reboot automatically at least once. It can take up to two minutes for the reboot process to be complete.

1. Turn off the display manually by holding the power button down for about two seconds.
2. Tap **Shutdown**. The display powers off and saves a backup of the database.
3. Power on the display by holding down the power button briefly (about one half of a second).
4. Insert the USB drive in either socket of the XCN-2050 display.
5. At the [Launcher screen \(page 39\)](#), tap .
6. Tap **Firmware Upgrades**.
7. A list displays with the firmware versions available.
8. Choose the version of the firmware package for FM-1000 Plus application and XCN-2050 application you want to upgrade to.
9. Tap the checkmark to continue the upgrade.

Note – Do NOT shut down the system during upgrades. The upgrade process can take at least 10 minutes, depending on your system's configuration. The system will reboot automatically at least once. It can take up to two minutes for the reboot process to be complete.

Wireless upgrades

Note – Do NOT shut down the system during upgrades. The upgrade process can take at least 10 minutes, depending on your system's configuration. The system will reboot automatically at least once. It can take up to two minutes for the reboot process to be complete.

Note – Wireless upgrades require a DCM-300 modem, a subscription to Office Sync and a data plan or access to WiFi. See [Wi-Fi settings \(page 94\)](#) and [DCM-300 Modem \(page 144\)](#).

1. Tap **Shutdown**. The display powers off and saves a backup of the database.
2. Power on the display by holding down the power button briefly (about one half of a second).
3. At the [Launcher screen \(page 39\)](#), tap .
4. Tap **Firmware Upgrades**.
5. Tap **Check for Updates**.
6. A list displays with the firmware versions available.
7. Choose the version of the firmware package for FM-1000 Plus application and XCN-2050 application you want to upgrade to.
8. Tap the checkmark to continue the upgrade.

Settings for wireless upgrades

To access display settings, see [Access display settings \(page 91\)](#).

You can control how FM-1000 Plus application checks for upgrades and when to wirelessly download them.

1. Tap **Firmware Upgrades**.
2. Tap **Settings**.

Setting	Explanation
Auto check for new upgrades	If you activate this, the system will automatically check for new upgrades.
Auto download new upgrades when available	This choice is only available if you have chosen to have the system automatically check for new upgrades. The system will install the updates as they are available.
Auto install firmware on power down	This choice is only available if you have chosen to have the system automatically check for new upgrades. The system will install the updates before the display powers off.
Only download via WiFi	This choice is only available if you have chosen to have the system automatically check for new upgrades. The system

Setting	Explanation
	will download the updates only through a WiFi connection.
Show support beta releases in list	The system includes beta releases available for you to download.

Installed packages

To access display settings, see [Access display settings \(page 91\)](#).

1. Tap **Firmware Upgrades**.
2. Tap **Installed Packages**.

Check for updates

To access display settings, see [Access display settings \(page 91\)](#).

1. Tap **Firmware Upgrades**.
2. Tap **Check for Updates**. If you are set up for wireless upgrades the system checks for updates and begins the upgrade process immediately unless you have altered when the upgrade occurs in Settings.

Feature unlocks

Note – If you are using the XCN-2050 display for the first time, you must first obtain a GPS position for unlocks to become active. If the display was installed indoors, you must move the equipment with the display outside to gain satellite access.

For some optional features, you must enter the unlock password. If you do not have an unlock password, contact your local reseller.

To access display settings, see [Access display settings \(page 91\)](#).

Tap **Feature Unlocks**. You can unlock features by manually entering the code, having the display read the QR code of the unlock, or checking for unlocks.

At the bottom of the screen, the list of currently locked features displays.

Manual code entry

1. Tap the Code text box and enter the code.
2. If the system accepts the code, tap **Accept**.
3. If the system rejects the code, you can try again or contact your reseller for help.

QR code scan

1. Tap **Read QR**.
2. Hold your code image in front of the camera for it to be read.
3. If the system accepts the code, Tap **Accept**.
4. If the system rejects the code, you can try again or contact your reseller for help.

Check for unlocks

1. Tap **Check for Unlocks**.
2. The request will be sent for the display to check for any available service or licenses. It may take several minutes for the unlocks to be processed.

Activate features/plugins for use

All features that have been unlocked must be activated (or "added") for use before you can set up or use them.



1. Open the FM-1000 Plus application if you are not already in it.
2. At the *Home* screen, tap .
- Note* – To add or remove features/plugins, you must access the *Configuration* screen only from the *Home* screen.
3. At the *Configuration* screen, tap **Add/Remove**. The *Select Active Plugins* screen displays.
4. To use a feature, select it from the *Inactive Plugins* list and tap **Add >**.
5. To stop using a feature, select it from the *Active Plugins* list and tap **<Remove**.
6. When you are finished with your choices, tap **OK**. The system returns you to the *Configuration* screen.

FM-1000 Plus application settings



To complete the settings for the FM-1000 Plus application, at the *Configuration* screen, select the *System* option and then tap **Setup**. The *Display Setup* screen displays.

If required, enter the administrator password. See [FM-1000 Plus application Passwords \(page 51\)](#).

1. At the *Configuration* screen, tap  *System* in the list, then tap **Setup**.
2. If necessary, enter the administrator password. See [FM-1000 Plus application Passwords \(page 51\)](#).
3. The *Display Setup* screen displays.
4. At this screen, you can navigate to and edit:
 - [Data dictionary \(page 62\)](#)
 - [EZ-Remote Joystick \(page 64\)](#)
 - [Field feature mapping settings \(page 65\)](#)
 - [Guidance settings \(page 66\)](#)
 - [Language, measurements, keyboard layout \(page 67\)](#)
 - [Lightbar settings \(page 68\)](#)
 - [Map settings \(page 70\)](#)
 - [Port settings \(page 74\)](#)
 - [Signal input module for OEM switch \(page 77\)](#)
 - [Status items \(page 79\)](#) that display on the *Run* screen

You can also return the display to its default settings. See [Restore default settings \(page 76\)](#).

Data dictionary

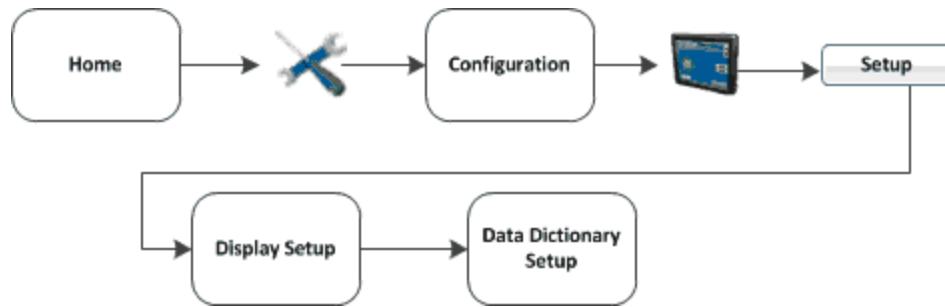

For information about data management, see:

- [Managing data \(page 96\)](#)
- [Data Dictionary categories \(page 112\)](#)
- [Create / load a data dictionary \(page 113\)](#)

Data Files

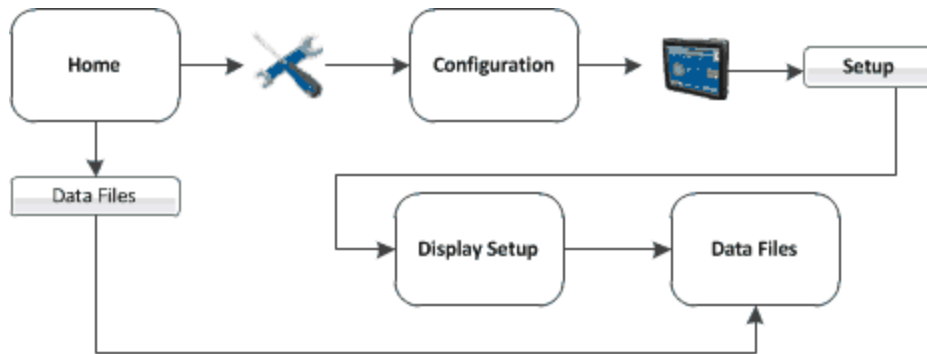

At the *Data Files* screen, you can transfer data. See [Transfer data \(page 96\)](#).

You can access the *Data Files* screen from the *Display Setup* screen as well as from the *Home* screen.

EZ-Remote Joystick

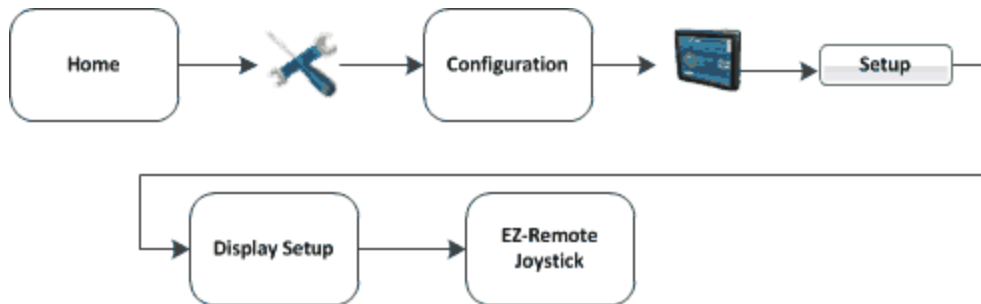

For installation information, see the *EZ-Remote Joystick Quick Reference Card*.

If you use the EZ-Remote joystick, you do not need to tap buttons on the display. This improves your accuracy when you select buttons, and gives you faster reaction times. You can program the EZ-Remote joystick to controls the functions of the FM-1000 Plus application.

Note – The functions available to assign to each button depend on which optional features (plugins) are activated on the display.

1. Connect the EZ-Remote joystick into into a CAN connection on Port A or B of the TM-200 Module. An EZ-Remote joystick icon automatically displays on the *Configuration* screen.
2. At the *Configuration* screen, select *EZ-Remote* and then tap **Setup**. The *EZ-Remote Assignment* screen displays.

Configure each key for the function you want to control remotely. You can also adjust the brightness of the LED joystick buttons.

3. On the EZ-Remote joystick, press the first button you wish to program. The *Function Assignment* screen displays.
4. Tap the feature that you want to program into that button on the control joystick.
5. Tap **Set** and then tap **OK**. The *Keypad Assignment* screen displays again.
6. Repeat steps 2 through 5 to program more buttons as required.
7. When completed, tap **OK**.

Note – You can configure the EZ-Remote control joystick while operating in a field. From the *Run* screen, tap  and then follow the previous steps.

Field feature mapping settings

A field feature is an item you designate on the display while you're in your field to indicate lines (such as fences), areas (such as areas to exclude) and points (such as rocks).

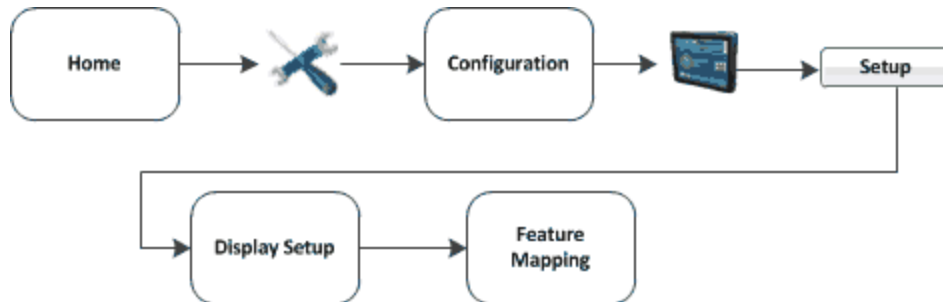

The field feature mapping settings determine:

- What buttons are available on the Mapping Guidance panel of the *Run* screen for creating features in the field
- The reference point for creating field features (center, left or right of the boom)
- If a path should be recorded when you begin logging coverage
- The types of warnings that can trigger when entering a feature or area
- When to restrict remote output
- How a boundary is recorded

For detailed information, see [Field feature mapping settings \(page 148\)](#).

Guidance settings

Note – If you are setting up the system for the first time, you should not need to adjust these settings.

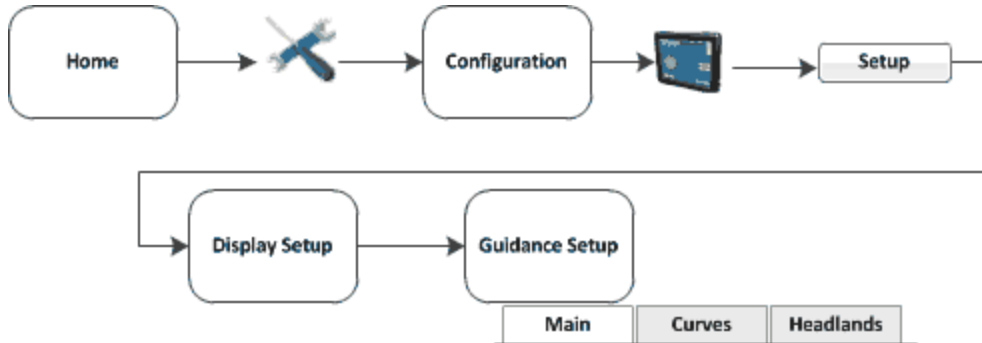

Setting	Explanation
Limit Field Selection	<p>Limits the number of fields that display when you are selecting a field.</p> <ul style="list-style-type: none"> • Yes: Enables Limit Field Selection. The displayed fields are within the set radius of the vehicle's current location, based on the vehicle's GPS position. • No: Disables Limit Field Selection • Selection Radius: Fields that fall within this radius will display. To exclude: <ul style="list-style-type: none"> • More fields, enter a smaller number • Fewer fields, enter a larger number
Auto Steering Lockout	<p>Disables engagement of an automated guidance system until you enable guidance in the <i>Run</i> screen.</p> <ul style="list-style-type: none"> • Yes: System functions as normal. Auto Guidance Enabled on/off is still allowed. • No: System cannot engage. The Engage button shows as red.

Language, measurements, keyboard layout

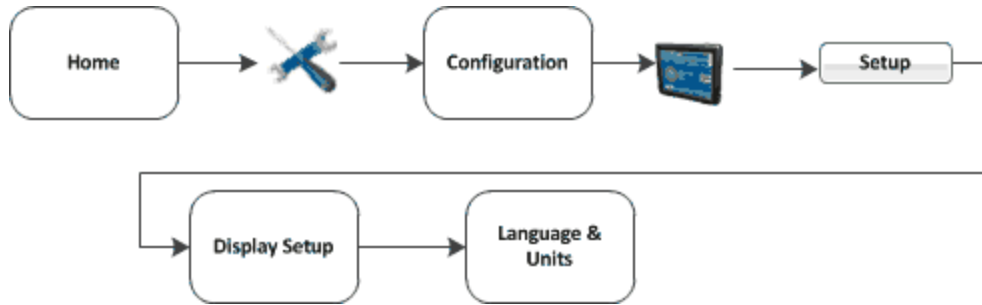

Setting	Explanation
Language Selection	<p>Same as XCN: Sets the language for the FM-1000 Plus application to be the same as that of the XCN-2050 display. This is the default settings.</p> <p>To set the language for the display, see Languages and units settings for display (page 92).</p> <p>FM-1000 Only: Enables you to set a language for the FM-1000 Plus application that is different from the language set for the XCN-2050 display.</p>
Display Units	<p>Select the unit of measure for the display:</p> <ul style="list-style-type: none"> • Metric • Feet and Inches (default) • Decimal Feet
Keyboard Layout	<p>The FM-1000 Plus application uses an on-screen keyboard on the touchscreen. Options for layout:</p> <ul style="list-style-type: none"> • ABCDEF: Letters appear in alphabetical order • QWERTY: Layout the same as a computer keyboard (default)

Lightbar settings

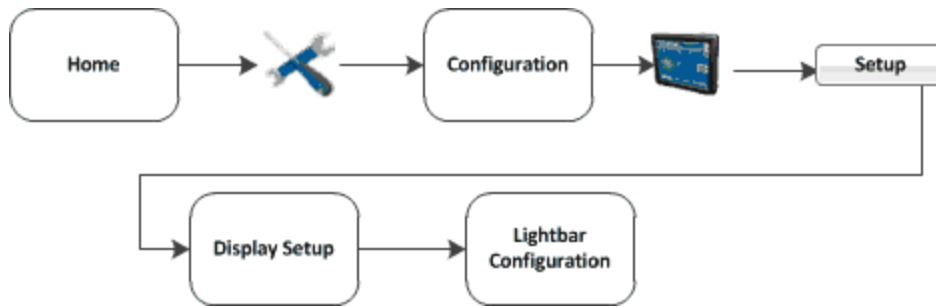

On-screen lightbar

You can edit the default settings for the on-screen (virtual) lightbar.

1. At the *Display Setup* screen, select **Lightbar**.
2. Tap **Setup**. The *Lightbar Configuration* screen displays.
3. Tap **Virtual Lightbar** and tap **Setup**.
4. Complete the settings as appropriate.

Setting	Explanation
LED spacing	<p>The distance represented by each LED on the lightbar.</p> <ol style="list-style-type: none"> a. Tap the appropriate number field. b. Enter the required values. <p>Default: 3 cm per LED/1" per LED</p>
Display Mode	<p>How the LEDs respond to offline distances. When “Show error” is selected, the FM-1000 Plus application shows the direction that you need to move in. When Show correction is selected, the FM-1000 Plus application shows your current distance offline.</p> <ol style="list-style-type: none"> a. From the list, tap the appropriate option. b. Enter the virtual lightbar settings, then tap OK. c. At the <i>Lightbars Configuration</i> screen, tap OK. <p>Default: show error (chase mode)</p>

External lightbar

To set up the external lightbar:

1. Connect the LB25 lightbar to any available CAN connection on Port A or Port B of the AG-815 integrated radio.
2. At the *Display Setup* screen, tap **Lightbar**.
3. Tap **Setup**. The *Lightbar Configuration* screen displays.
4. Tap **Lightbar** and tap **Setup**.
5. Complete the settings as appropriate.

Setting	Explanation
Name	Name and serial number of the lightbar
Orientation	Choose the orientation of the lightbar
Brightness	Setting for how bright the lightbar displays
LED Spacing	The distance represented by each LED on the lightbar. <ol style="list-style-type: none"> a. Tap the appropriate number field. b. Enter the required values. Default: 3 cm per LED/1" per LED
Lightbar Purpose	Choose the purpose of the lightbar
Look ahead time	The distance ahead of the vehicle that the lightbar will use for LED guidance and offline distance. Default: 0 seconds

Map settings

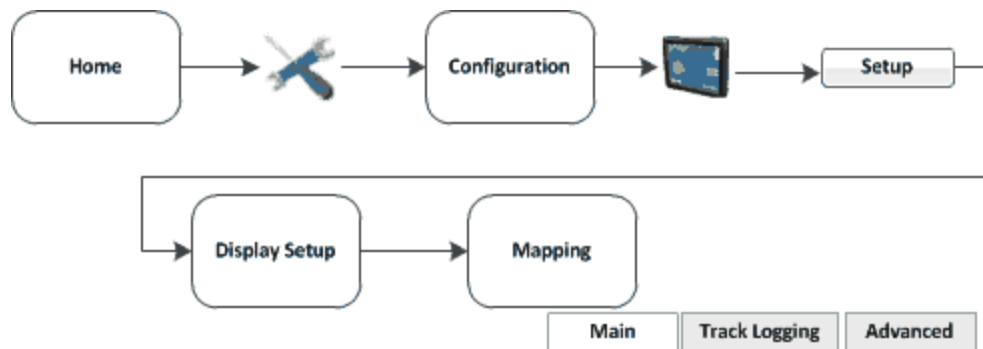

At the *Mapping* screen, you can complete settings on these tabs:

- [Main](#)
- [Track Logging](#)

Main tab

Note – For a new toolbar orientation to take effect, restart the display.

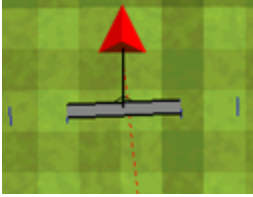
Setting	Explanation
Map orientation	<p>Controls the direction that the screen follows the position of the vehicle.</p> <ul style="list-style-type: none"> • North Up: When you perform a turn, the field remains stationary and the vehicle turns.  <ul style="list-style-type: none"> • Vehicle Up: When you perform a turn, the field rotates but the vehicle remains pointing up.  <p>Note – To change the map orientation from the Run screen, tap the north arrow.</p>
Color scheme	Default mode
Save summaries	<ul style="list-style-type: none"> • On: The FM-1000 Plus application creates a saved file for your work. • Off: The FM-1000 Plus application does not create a saved file for your work.

Track Logging tab

On the TrackLogging tab, you can configure the FM-1000 Plus application to record the vehicle track at either a set time or a set distance. Points along the track are logged at the greater of the two values (either logging time or logging distance).

To always log a point based on either of the two values, set the other value to zero. To disable track logging, set both values to zero.

Setting	Track logging is...
Distance = 0, Time = 0	Turned off
Distance = 1+, Time = 0	Recorded by distance (m)
Distance = 0, Time = >1+	Recorded by time (s)
Distance = >1+, Time = >1+	Recorded by whichever setting is higher

Track logging files

Track logging files are created whenever you open an event. The track file records points at the rate set on the [Track Logging](#) tab. At each point, a number of attributes are recorded.

Note – The data stored in the track logging file (*Track3D_<date time>.dbf*) is in metric units.

The information stored for each point in the track logging file is listed in the following table.

Column	Description	Units
Along_Line	Along line distance from start of swath. Attribute Not Populated	meters
Ant_HAE	Antenna height above ellipsoid. Attribute Not Populated.	meters
Ant_Lat	Antenna latitude (WGS-84).	DD.dddddddd
Ant_Long	Antenna longitude (WGS-84).	DD.dddddddd
Appln_Width	Application width.	meters
As_Applied	Applied rate. Attribute Not Populated	–
Auto_Steer	Auto-Steer flag (1=on, 0=off).	On or off
Corct_Age	DGPS signal correction age.	seconds
Field_Name	The name of the field.	–
GPS_Status	GPS status value (NMEA).	1, 2, 5, 4
Ground_HAE	Ground height above ellipsoid. Attribute Not Populated	meters
HDOP	Horizontal Dilution of Precision – A measure of the quality of positions based on satellite geometry.	–
Heading	Direction of travel with respect to true North.	decimal degrees

Column	Description	Units
Height	Mean sea level height of ground.	meters
Local_Time	Local time.	hh:mm:ss.s
Logging_On	Coverage logging flag (1=on, 0=off).	On or off
Num_Stats	Number of GPS satellites.	–
Offline	Offline distance from swath center line.	meters
Pitch	The pitch. Attribute Not Populated	–
Relative_Height	Height.	meters
Roll	The roll. Attribute Not Populated	–
Speed	GPS-derived ground speed.	kph
Status_Text	GPS status description.	–
Swath_Num	Current swath/headland number.	
Swath_Wdth	Swath width.	meters
Target	The target rate at the current position.	–
Total_Qty	Total volume of material as applied for the current field. Only supported for the Aerial Flow Controller, Autocal Flow controller, and Crophawk Flow Meter.	–
Units	Units. Attribute Not Populated	metric
UTC_Date	Point creation date.	YYYYMMDD
UTC_Time	UTC time.	hh:mm:ss.s
Version	Track attribute file version.	–
Yaw	The yaw. Attribute Not Populated	–

Port settings

The *Port Setup* screen displays information about:

- Receiver connection status
- The TM-200 Module serial number
- The serial number of the AG-815 integrated radio, if connected

To configure your system:

1. Connect hardware. See the *XCN-2050 Cabling Guide*.
2. [Assign](#) the primary USB port and the EXP-100(s) in the *Port Setup* screen.
3. Complete port information for each optional feature/plugin as you set it up.

Assignments

1. Choose which EXP-100 is used as primary, secondary and tertiary.
2. Assign which USB port of the XCN-2050 display should be used to transfer data to a USB drive.

Setting	Choose the serial number of the...
EXP-100 #1	Primary EXP-100 Note – Typically used for SerialVR or external receivers. Equivalent to Port A or Port B on a physical FM-1000 integrated display.
EXP-100 #2	Secondary EXP-100 Note – Typically used for SerialVR or external receivers. Equivalent to Port A or Port B on a physical FM-1000 integrated display.
Receiver EXP-100 or AG-815 integrated radio (This label changes, depending on your configuration)	EXP-100 (third port expander cable) Note – Used to assign GNSS-2 or external radios. Typically used for TrueTracker. Equivalent to Port D on a physical FM-1000 integrated display.

Configuration principles

Use these rules to configure the settings of your configuration.

- Any serial connection requires an EXP-100. You can connect up to three EXP-100s together. However, port A of the TM-200 Module is used for Autopilot.
- For CAN connections, two CAN ports are available on the TM-200 Module. The EZ-Steer system and EZ-Pilot system use Port B on the TM-200 Module.

Restore default settings

Note – These default settings for the FM-1000 Plus application are different from the [Restore defaults \(page 94\)](#) settings for the XCN-2050 display.

You can reset the FM-1000 Plus application to its default values. This can be useful if:

- You made changes to the display settings. The results are poor, but you cannot determine which setting was the cause.
- You move the display from one vehicle to another.

Note – If you restore the defaults, the Autopilot vehicle setup information is not reset.

To restore the default settings:

1. At the *Configuration* screen, select the  System option and then tap **Setup**. The *Display Setup* screen displays.
2. Tap **Default**. A confirmation screen displays.
3. Tap **Yes**. The default settings are restored.

Signal input module for OEM switch

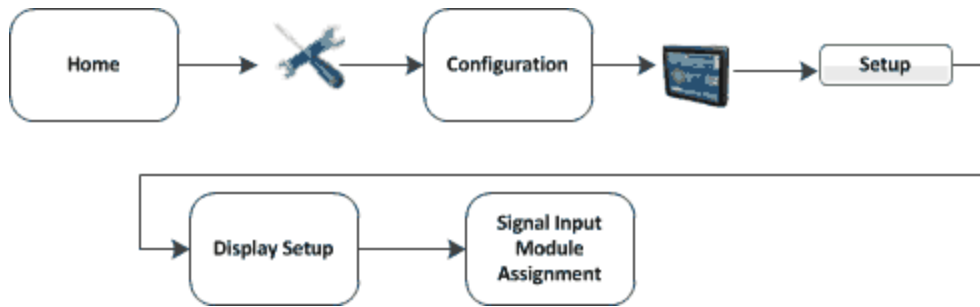

The signal input module (SIM) can interface with existing equipment inputs to control on-screen buttons and features. A SIM must be connected to assign features to the buttons.

1. To assign the buttons, highlight the action in the Actions list.
2. Tap <-- Set to set the action to the specified input.

Sounds

The ways sounds can be produced are:

- Through the internal speaker of the FM-1000 Plus application
 - If Autopilot is part of your configuration, you can use an external Sonalert
1. At the *Display Setup* screen, select Sounds and tap setup.
 2. Complete the settings and tap **OK**.

Setting	Explanation
Alarm	Off, External Speaker, AP Sonalert. Note – Sonalert works only with Autopilot.
Warning	Off, External Speaker, AP Sonalert. Note – Sonalert works only with Autopilot.
Track Logging	Off, External Speaker
Touch Screen	Both high, Off, External low

Status items

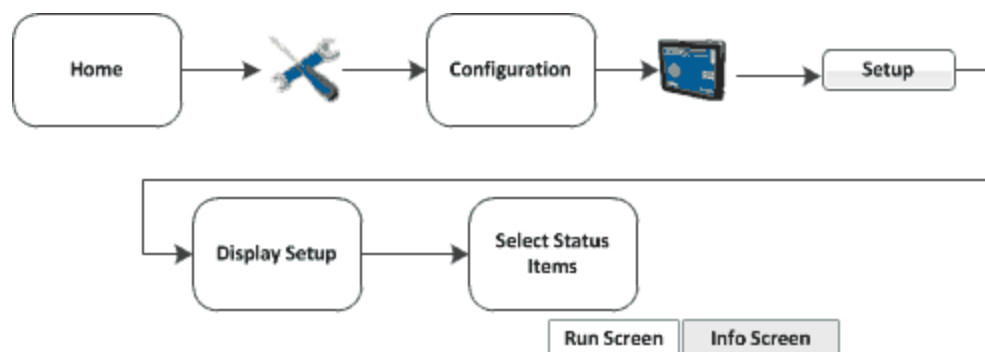

The status items are features you have activated for use. See [Activate features/plugins for use \(page 60\)](#). If a feature is deactivated, the status items associated with it are no longer available.

The *Select Status Items* screen has two tabs where you can configure various FM-1000 Plus application options for the status text items.

Run screen slide-out status

On the Run Screen tab, you can set what items display on the *Run* screen in the status slide-out panel when you tap the edge of the panel. The status text items appropriate for the features/plugins you are currently using display in the *Info Items* list.

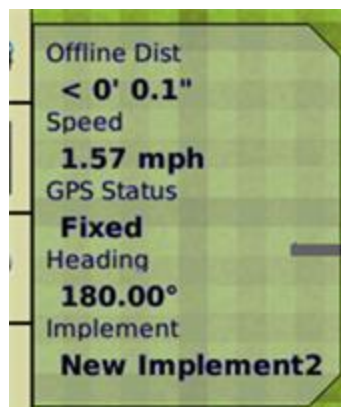

1. Set the upper left status text item:
 - a. From the Info Items list, tap the item you want to use.
 - b. Tap the left ^ **Set Item** button. The information displays in the upper left field.
2. Set the upper right status text item:
 - a. From the Info Items list, tap the item you want to use.
 - b. Tap the right ^ **Set Item** button. The information displays in the upper right field.

3. From the *Timeout* list, select a time. This is how long the tab remains on-screen before retracting. To have the tab extended until you close it manually, select *Never*.
4. To add status items to the slide-out tab:
 - a. Tap the position on the tab that you want to fill. For example, to add an item to the first position on the list, tap at the location shown.
 - b. From the *Info Items* list, tap the item you want to use.
 - c. Tap **<- Set Item**.
5. To save the configuration, tap **OK**.

Info screen

On the *Info Screen* tab, you can determine which items will be displayed on the *Info* panel when you tap .

The status text items appropriate for the features/plugins you are currently using display in the *Info Screen* list.

1. Set the left *Info* text items:
 - a. From the *Info Items* list, tap the item you want to use.
 - b. Tap the left **^ Set Item** button.
 - c. Repeat steps a and b until you have all the items you want, or the list is full. The information displays in the left field.
2. Set the right *Info* text items:
 - a. From the *Info Items* list, tap the item you want to use.
 - b. Tap the right **^ Set Item** button.
 - c. Repeat steps a and b until you have all the items you require, or the list is full. The information displays in the right field.
3. To save the configuration, tap **OK**.

Status option list

The following list shows the status items you can choose to display on the *Run* screen. The status items available depend on the optional features/plugins that are currently activated.

In the *Display Setup* screen, select **Status Items** and then tap **Setup**.

Status Item	Explanation
(blank)	Status text item is not shown
Along Track Error	

Status Item	Explanation
Altitude	Current height of the vehicle
Applied Rate	Current application rate
Area to Empty	Area that can still be applied before the tank is empty
Auxiliary Valve	Current status of the auxiliary valve
Available Memory	Amount of free space on the display's internal memory
Average Population	Average rate across all rows
Avg Seed Spacing	Average distance between seeds based on the average sample size
Blade Height	Current height of the blade
Boot Depth	Depth of the boot when installing tiles or the depth of the blade when cleaning surface ditches (used with the Autoslope leveling model)
CH1 - CH4 Product Level	Current level of the products that are in channels 1-4
Client Name	Name of the current client
CMR Percent	Percentage of radio CMR packets received over the last 100 seconds
Control Speed	Speed reported to the multi-application controller
Correction Age	Length of time since the last correction was received
Correction Type	Correction type that is being used
Coverage Percent	Percentage of the field area that is covered area
Current Flow	Current flow of material
Cut/Fill	<p>Difference between the Blade Height and the Target Height:</p> <ul style="list-style-type: none"> • When Cut is shown, the current ground height is above the target height. The height adjustment indicator shows a red down arrow, which means that the blade needs to move down to reach the Target Height. • When Fill is shown, the current ground height is below the target height. The height adjustment indicator shows a red up arrow, which means that the blade needs to move up to reach the Target Height.
Design Height	Height the blade will attempt to reach. This is the Design Height \pm the Offset. When the blade reaches the Target Height, the arrows turn green.

Status Item	Explanation
Design Slope	When using the Autoslope leveling model, this displays the design slope with respect to the current location along the section line.
Dist to Feature	Distance to the nearest feature
Dist to Pause	Distance to the pause position
East	Distance that the vehicle is to the east of the field origin point (a negative number means the vehicle is to the west of the field origin point)
Engaged Time	Length of time that the system has been engaged
Event Coverage Area	Area that has been logged during the current event
Event Coverage Distance	Distance covered while logging during the current event
Event Coverage Time	Length of time that coverage logging has been engaged during the current event
Event Name	Name of the current event
Farm Name	Name of the current farm
Field Area	Field area within a pivot or headland boundary
Field Name	Name of the current field
Free External Storage	Amount of free space on the USB drive
Free Internal Storage	Amount of free space on the display's internal memory
GMT Time	Current Greenwich Mean Time
GPS Position Spacing	
GPS Status	GPS correction type that the GPS receiver is currently using
H Error	Horizontal error: An estimation of the level of precision of the GPS position in 2 dimensions
Heading	Current heading of the vehicle, in degrees, from direct north
Heading to Feature	Vehicle location relative to the nearest feature (feature is directly ahead = 0°; directly behind = 180°)
Heading to Pause	Direction vehicle is facing relative to the paused vehicle position (directly ahead = 0°; directly behind = 180°)
Impl. Altitude	Current height of the implement
Impl. CMR Percent	Percentage of radio CMR packets received by the implement GPS

Status Item	Explanation
	receiver over the last 100 seconds
Impl. Correction Age	Age of the corrections used by the implement receiver
Impl. Correction Type	Correction type used by the implement receiver
Impl. East	Distance that the implement is to the east of the field origin point (a negative number means the implement is to the west of the field origin point)
Impl. Engaged Time	Time that the implement has been engaged
Impl. GPS Status	The status of the GPS correction used for the implement
Impl. H Error	Implement horizontal error: An estimation of the level of precision of the implement GPS position in 2 dimensions
Impl. HDOP	Horizontal Dilution of Precision of the implement receiver: A measure of accuracy based on the geometry of the satellites in the sky. If the satellites are near each other in the sky, the HDOP is higher (lower is better).
Impl. Heading	Current heading of the implement, in degrees, from direct north
Impl. Latitude	Implement's current latitude
Impl. Long-Term XTE	Implement Cross Track Error (XTE) when passes occur more than one hour apart
Impl. Longitude	Implement's current longitude
Impl. Network ID	RTK network ID of the implement receiver's corrections
Impl. North	Distance that the implement is to the north of the field origin point (a negative number means the implement is to the south of the field origin point)
Impl. Nudge/Trim	Amount of nudge or trim currently applied to the implement position
Impl. Offline Dist	Distance away from the guidance line
Impl. Satellites	Number of satellites the implement receiver is reading
Impl. Short-term XTE	Implement pass-to-pass Cross Track Error (XTE) when passes occur within less than 15 minutes
Impl. Speed	Current implement speed

Status Item	Explanation
Impl. Steering Angle	Steering angle of the implement
Impl. Up	Vertical height of the implement relative to the field origin point (a negative number means the implement is lower than the field origin point)
Impl. Vehicle Model	Implement profile name
Implement	Name of the current implement
Implement F/B Offset	Distance of front to back offset
Implement L/R Offset	Distance of left to right offset
Implement Width	Width of the implement
Latitude	Vehicle's current latitude
Line Feature Length	Length of the current line feature
Local Time	Current local time
Long-term XTE	Vehicle Cross Track Error (XTE) when passes occur more than one hour apart.
Longitude	Vehicle's current longitude
Longitude	Vehicle's current longitude
NDVI	Normalized Difference Vegetation Index
Nearest Point Name	Name of the nearest point feature
Network ID	RTK network ID of the GPS receiver's corrections
Network Status	Current status of the wireless cellular network
North	Distance that the vehicle is to the north of the field origin point (a negative number means the vehicle is to the south of the field origin point)
Nudge	Amount of nudge currently applied
Nudge/Trim	Amount of nudge or trim currently applied
Offline Dist.	Distance away from the guidance line
Offset X	Relative Position X offset from the master benchmark
Offset Y	Relative Position Y offset from the master benchmark
P Altitude	Current height of the vehicle as reported by the primary blade GPS

Status Item	Explanation
	receiver
P Blade Height	Current height of the primary blade
P Boot Depth	Depth of the boot when installing tiles or the depth of the blade when cleaning surface ditches (used with the Autoslope leveling model)
P CMR Percent	Percentage of radio CMR packets received over the last 100 seconds by the primary blade GPS receiver
P Correction Age	Time since the GPS corrections were last received from the primary FieldLevel™ GPS receiver
P Correction Type	Correction type used by the primary blade receiver
P Cut/Fill	Difference between the Primary Blade Height and the Primary Target Height: <ul style="list-style-type: none"> • When Cut is shown, the current ground height is above the target height. The height adjustment indicator shows a red down arrow, which means that the blade needs to move down to reach the Target Height. • When fill is shown, the current ground height is below the target height. The height adjustment indicator shows a red up arrow, which means that the blade needs to move up to reach the Target Height.
P Design Height	Height the primary blade will attempt to reach. This is the Design Height ± the Offset. When the blade reaches the Target Height, the arrows turn green.
P Design Slope	When using the Autoslope leveling model, this displays the design slope with respect to the current location along the section line.
P Distance Traveled	Distance traveled since Auto mode was enabled. (For use with FieldLevel II Point to Slope mode). The d
P East	Distance that the primary blade receiver is to the east of the field origin point (a negative number means the receiver is to the west of the field origin point)
P GPS Status	GPS correction type that the primary blade GPS receiver is currently using
P H Error	(Horizontal error) An estimation of the level of precision of the primary blade GPS position in 2 dimensions

Status Item	Explanation
P HDOP	Horizontal Dilution of Precision of the primary blade receiver: A measure of accuracy based on the geometry of the satellites in the sky. If the satellites are near each other in the sky, the HDOP is higher (lower is better).
P Heading	Current heading of the primary blade, in degrees, from direct north
P Latitude	Primary blade's current latitude
P Longitude	Primary blade's current longitude
P Network ID	RTK network ID of the primary blade receiver's corrections
P North	Distance that the primary blade receiver is to the north of the field origin point (a negative number means the receiver is to the south of the field origin point)
P Offset	Separate plane that is parallel to the design plane. The offset is defined by a single measurement, which is the height that the offset plane is from the design plane.
P Offset X	Relative Position X offset from the master benchmark
P Offset Y	Relative Position Y offset from the master benchmark
P Satellites	Number of satellites the system is currently being received by the FieldLevel II GPS receiver
P Section Line Number	Line number of the primary blade
P Speed	Speed of the vehicle as reported by the primary blade GPS receiver
P Target Height	Height the primary blade will attempt to reach. This is the Design Height \pm the Offset. When the blade reaches the Target Height, the arrows turn green.
P Up	Height of the primary blade receiver relative to the field origin point (a negative number means the blade is lower than the field origin point)
P VDOP	Vertical Dilution of Precision of the FieldLevel II GPS receiver: A measure of accuracy based on the geometry of the satellites in the sky. If the satellites are near each other in the sky, the VDOP is higher (lower is better).
P Vertical Error Estimate	Current estimate of error in the height calculated by the FieldLevel II GPS receiver
Pressure	Current pressure as reported by the primary pressure sensor

Status Item	Explanation
Productive Area	Area of Area Features that are designated as "productive"
Radio Signal Strength	DCM-300 wireless signal strength
S Altitude	Current height of the vehicle as reported by the secondary blade GPS receiver
S Blade Height	Current height of the secondary blade
S CMR Percent	Percentage of radio CMR packets received over the last 100 seconds by the secondary blade GPS receiver
S Correction Age	Time since the GPS corrections were last received from the secondary FieldLevel GPS receiver
S Correction Type	Correction type used by the secondary blade receiver
S Cut/Fill	<p>Difference between the Secondary Blade Height and the Secondary Target Height:</p> <ul style="list-style-type: none"> • When Cut is shown, the current ground height is above the target height. The height adjustment indicator shows a red down arrow, which means that the blade needs to move down to reach the Target Height. • When Fill is shown, the current ground height is below the target height. The height adjustment indicator shows a red up arrow, which means that the blade needs to move up to reach the Target Height.
S Design Height	Height the secondary blade will attempt to reach. This is the Design Height \pm the Offset. When the blade reaches the Target Height, the arrows turn green.
S Distance Traveled	Distance traveled since Auto mode was enabled (for use with FieldLevel II Point to Slope mode)
S East	Distance that the secondary blade receiver is to the east of the field origin point (a negative number means the receiver is to the west of the field origin point)
S GPS Status	GPS correction type that the secondary blade GPS receiver is currently using
S H Error	(Horizontal error) Estimation of the level of precision of the secondary blade GPS position in 2 dimensions
S HDOP	Horizontal Dilution of Precision of the secondary blade receiver: A measure of accuracy based on the geometry of the satellites in the

Status Item	Explanation
	sky. If the satellites are near each other in the sky, the HDOP is higher (lower is better).
S Heading	Current heading of the secondary blade, in degrees, from direct north
S Latitude	Secondary blade's current latitude
S Longitude	Secondary blade's current longitude
S Network ID	RTK network ID of the secondary blade receiver's corrections
S North	Distance that the secondary blade receiver is to the north of the field origin point (a negative number means the receiver is to the south of the field origin point)
S Offset	Separate plane that is parallel to the design plane. The offset is defined by a single measurement, which is the height that the offset plane is from the design plane.
S Offset X	Relative Position X offset from the master benchmark
S Offset Y	Relative Position Y offset from the master benchmark
S Satellites	Number of satellites the system is currently being received by the FieldLevel II GPS receiver
S Section Line Number	Line number of the secondary blade
S Speed	Speed of the vehicle as reported by the secondary blade GPS receiver
S Target Height	Height the secondary blade will attempt to reach. This is the Design Height \pm the Offset. When the blade reaches the Target Height, the arrows turn green.
S Up	Height of the secondary blade receiver relative to the field origin point (a negative number means the blade is lower than the field origin point)
S VDOP	Vertical Dilution of Precision of the FieldLevel II GPS receiver: A measure of accuracy based on the geometry of the satellites in the sky. If the satellites are near each other in the sky, the VDOP is higher (lower is better).
S Vertical Error Estimate	Current estimate of error in the height calculated by the FieldLevel II GPS receiver
Satellites	Number of satellites the system is currently receiving

Status Item	Explanation
Secondary Pressure	Current pressure, as reported by the secondary pressure sensor
Section Line Number	Number of the current section line
Seed Mults %	Percentage of time an more than one seed is placed for every intended drop
Seed Population	Amount of seed planted per acre/hectare
Seed Singulation	Percentage of time an individual seed is placed for every intended drop
Seed Skips %	Percentage of seed that has not been planted
Seed Spacing	Percentage of seed that has been applied in the specified spacing
Session Coverage Area	Area that has been logged during the current session
Session Coverage Dist	Distance covered while logging during the current session
Session Coverage Time	Length of time that coverage logging has been engaged during the current session
Session Time	Length of the current field session
Short-term XTE	Vehicle pass-to-pass Cross Track Error (XTE) when passes occur within less than 15 minutes
Speed	Current vehicle speed
Steering Angle	Angle reported by the rotary potentiometer or the AutoSense™ device
Survey Area	Total area of the current survey
Survey Cut/Fill	<p>Difference between the Blade Height and the Target Height:</p> <ul style="list-style-type: none"> • When Cut is shown, the current ground height is above the target height. The height adjustment indicator shows a red down arrow, which means that the blade needs to move down to reach the Target Height. • When Fill is shown, the current ground height is below the target height. The height adjustment indicator shows a red up arrow, which means that the blade needs to move up to reach the Target Height.
Survey Points	Number of survey points that have been created
Swath Length	Length of the current guidance line

Status Item	Explanation
	Note – FreeForm™ curves are made up of line segments, so the Swath Length value is not appropriate for FreeForm curves.
Swath Number	Swath number (L = left, R = right) Note – FreeForm curves are made up of line segments, so the Swath Number value is not appropriate for FreeForm curves.
Swath Points	The number of points that define the current line.
Tank Level	Current level of the tank
Tank Level N	Level of nitrogen currently in the tank
Tank Level NH3	Level of anhydrous ammonia currently in the tank
Tank/Bin Level	Current level of the tank or bin
Target Rate	Application target rate
Total Boundaries Area	Total area between the current boundaries
Total Seed Rate	Total seed rate that is currently being applied
Total Vol Applied	Total volume of material applied
Total Vol Applied N	Total volume of nitrogen applied
Total Vol Applied NH3	Total volume of anhydrous ammonia applied
Transfer Status	Connected Farm™ transfer activity
TrueGuide Roll	Roll corrections in degrees that are applied
TrueGuide Trim	Distance from the guidance line that the vehicle has been shifted
Up	Vertical height of the vehicle relative to the field origin point (a negative number means the vehicle is lower than the field origin point)
VDOP	Vertical Dilution of Precision of the FieldLevel II GPS receiver: A measure of accuracy based on the geometry of the satellites in the sky. If the satellites are near each other in the sky, the VDOP is higher (lower is better).
Vehicle Model	Model of vehicle that is configured
Vehicle Type	Type of vehicle that is configured
Vertical Error Estimate	Current estimate of error in the height calculated by the FieldLevel II GPS receiver

Display settings

Most of the display settings affect the XCN-2050 display and the FM-1000 Plus application.



Access display settings

You can access settings for the XCN-2050 display from the:

- [Shortcut to settings](#)
- [Launcher screen](#)



Shortcut

You can access *XCN-2050 display settings only* using a shortcut.

1. Navigate to the [Home screen \(page 40\)](#) and tap **Close** to close the FM-1000 Plus application.
Note – *If you fail to close FM-1000 Plus application before rebooting, you may experience a loss of data.*
2. At the upper right of the display screen, swipe down.
3. Tap .
4. Tap .

Launcher screen

You can access *XCN-2050 display settings only* from the [Launcher screen \(page 39\)](#).

1. Navigate to the [Home screen \(page 40\)](#) and tap **Close** to close the FM-1000 Plus application.
Note – *If you fail to close FM-1000 Plus application before rebooting, you may experience a loss of data.*
2. Tap  to navigate to the [Launcher screen \(page 39\)](#).
3. Tap .

Note – *If you have an automatic steering system that is currently engaged, before you go to the Launcher screen, the steering system will disengage.*

Date and time settings

The time and date for the display and the FM-1000 Plus application is automatically obtained from the GNSS receiver in the TM-200 Module.

Setting	Tap to...
Automatic date and time	Turn on or off. If you choose to use the automatic date and time, the Set date and Set time controls are disabled. The display then obtains time and date from the GNSS receiver in the TM-200 Module.
Set date	Choose the current date. Scroll in the month, date and year columns.
Set time	Choose the current time. Scroll in the hour, minute and AM/PM columns.
Select time zone	Choose time zone. Scroll the list of time zones and tap the time zone that applies to you. You must set the time zone. The system does not automatically set this.
Use 24-hour format	Turn on or off.
Select date format	Choose the date format you want to see on the screen. Options are: MM/dd/YYYY, dd/MM, YYYY/MM/dd.

See [Access display settings \(page 91\)](#).

Languages and units settings for display

At this settings page, you can set for the XCN-2050 display (such as the [Launcher screen \(page 39\)](#)):

- The language
- The type of units of measure
- Whether the password entry is always obscured or delayed from being obscured

Setting	Tap to view or choose...
Languages	The language for the display. Scroll the list and tap the language you want.
Display Units	The type of units you want on the display: English or Metric
Number Format	Either commas or periods.

You can choose to have a different language on the FM-1000 Plus application from that on the XCN-2050 display. See [Language, measurements, keyboard layout \(page 67\)](#).

See [Access display settings \(page 91\)](#).

Users and passwords

User profiles and passwords are system-wide, meaning they are active for the FM-1000 Plus application and XCN-2050 application as well as other Trimble applications.

Setting	Tap to...
Enable Operators	Turn this feature on to use operator login.
Add User	Add a user
(Existing user name)	Edit the user profile

See [Access display settings \(page 91\)](#).

Add a user

1. Tap **Add User**.
2. Enter the Operator ID.
3. Enter and confirm the user's password.
4. Tap **Create User**.

Take a photo of a user

You can capture a photo of the user, which will display:

- Next to the user's information in the Users and passwords section of Settings
 - On the top display bar when the user is logged in
1. At the Users and passwords section, Tap the user icon on the right of the user information.
 2. The camera activates and displays a frame on the screen. Make sure the user's face is contained within this frame.
 3. To capture the photo, tap **Capture**. The photo displays on the lower right. You can continue to tap **Capture** until you are satisfied with the photo.
 4. When you are ready to save the photo, tap **Done**.

Wi-Fi settings

With a DCM-300 modem and additional subscription services, Wi-Fi enables you to transfer data wirelessly from:

- Vehicle to office using Office Sync
- Vehicle to vehicle using Vehicle Sync

You can use Wi-Fi in addition to or instead of the cellular network.

At Wi-Fi network settings, turn on Wi-Fi.

Note – Before you can configure Wi-Fi settings in the FM-1000 Plus application, you must turn this setting on for Wi-Fi to operate properly.

At Available Networks, tap **Refresh** to scan for additional networks you can connect to.

For content on:	See:
Diagnostics and status	GPS status (page 514)

Restore defaults

During troubleshooting, you may be asked by Support to perform a reset.

See [Access display settings \(page 91\)](#).

Admin User Options

Setting	Tap to...
Restore Default user Preferences	Restore the default preferences for the user currently logged in.
Restore Preferences to Factory Defaults	Restore the display to default factory settings. Erases all custom settings for all user accounts for FM-1000 Plus application and XCN-2050 application.
Factory Reset	Erase all user accounts, system and application data, coverage, configurations, feature unlocks, minor firmware updates and downloaded applications. Note – Only perform a factory reset on the advice of technical support.

Data management

In this chapter:

Managing data	96
Transfer data	96
Delete data	99
Data storage structure	101
Data Dictionary categories	112

This chapter explains:

- How to transfer data between a USB drive and the FM-1000 Plus application
- The structure of data on the USB and computer
- The Data Dictionary

Managing data

As part of data management, you can:

- Transfer files. See [Transfer data \(page 96\)](#).
- Delete files. See [Delete data \(page 99\)](#).
- Edit and add to the data entry categories by editing the data dictionary. See [Data Dictionary categories \(page 112\)](#).
- Create or load a data dictionary. See [Create / load a data dictionary \(page 113\)](#).
- View a PDF file of an event summary. See [Event subfolder \(page 105\)](#).
- Import an AB line or boundary. See [Import AB Lines or boundaries \(page 380\)](#).
- Save an Autopilot system vehicle configuration file (.vdb). See [Save vehicle profile \(page 186\)](#).

Files generated by the FM-1000 Plus application are saved in a specific structure on the USB drive. See [Data storage structure \(page 101\)](#).

Transfer data



At the *Data Files* screen, you can:

- Transfer data between a USB drive and the display's internal storage. See [Transfer to USB \(page 97\)](#) or [Transfer from USB \(page 98\)](#).
- Transfer data between a USB drive and a computer. See [USB to computer \(page 98\)](#).
- Delete data from a USB drive or the display's internal storage. See [Delete data \(page 99\)](#).

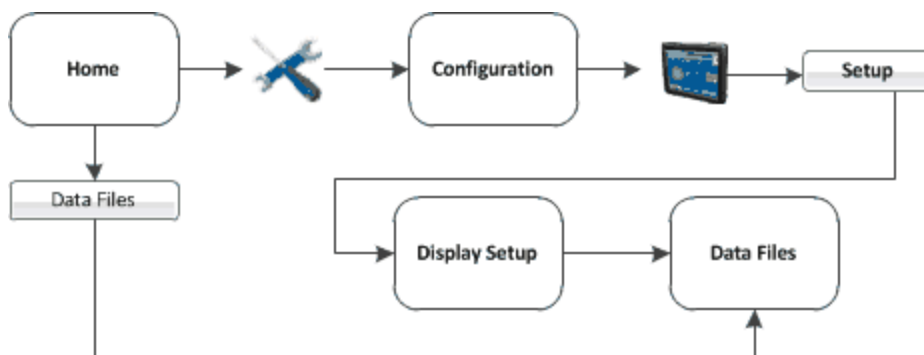
Data Files screen



You can access the *Data Files* screen from either:

- The *Home* screen: Tap **Data Files**.
- The *Configuration* screen:
 - a. At the **Home** screen, tap .
 - b. At the *Configuration* screen, tap  System and then tap **Setup**.
 - c. If necessary, enter the administration password and then tap **OK**.
 - d. Select Data Files from the list and then tap **Manage**. The *Data Files* screen displays.

Data File categories

The categories available on the Data Files screen are:

Category	Subcategories and data
Summary Files	PDF summary files listed under client name
Diagnostics	Screen shots: Folder containing screen captures System logs
Configuration	Features: Implements: System Archive: Varieties: Vehicle Archive:
Data Dictionary	Data dictionary. See Data Dictionary categories (page 112) .
Field Data	Data for all activities in the field. Data is structured as: Client / Farm / Field / Event

Transfer to USB



CAUTION – Do not remove the USB drive from the socket while the application is copying data. This will corrupt the data.







CAUTION – POTENTIAL LOSS OF DATA!

If you copy files from:

- An FM-1000 Plus application to another or to an FM-1000 integrated display.
- An physical FM-1000 integrated display to another or to an FM-1000 Plus application

First make sure you have created a subfolder labeled with the display serial number for your files. Transfer your files to this subfolder. Otherwise, you will overwrite files when you copy and you will corrupt your data.

- At the *Data Files* screen from the display's  Internal Storage list, tap the item to copy. You can:
 - Select all files in the category: Select the entire category by tapping the category name.
 - Select individual files: See files within a category by tapping . The arrow changes to a down arrow  and shows the files stored under the category. Then select the file or files you want.
 - Select all files: Select Everything.
- Tap **Copy** >. The item is copied to the  USB list.

Transfer from USB



CAUTION – Do not remove the USB drive from the socket while the application is copying data. This will corrupt the data.







CAUTION – POTENTIAL LOSS OF DATA!

If you copy files from:

- An FM-1000 Plus application to another or to an FM-1000 integrated display.
- An physical FM-1000 integrated display to another or to an FM-1000 Plus application

First make sure you have created a subfolder labeled with the display serial number for your files. Transfer your files to this subfolder. Otherwise, you will overwrite files when you copy and you will corrupt your data.

USB to FM-1000 Plus application

- At the *Data Files* screen from the  USB list, tap the item to copy. You can:
 - Select all files in the category: Select the entire category by tapping the category name.
 - Select individual files: See files within a category by tapping . The arrow changes to a down arrow  and shows the files stored under the category. Then select the file or files you want.
 - Select all files: Select Everything.
- Tap **Copy** >. The item is copied to the  Internal Storage list.

USB to computer

After you have transferred data from the FM-1000 Plus application to the USB:

- Remove the USB drive from the display.
- Insert the USB drive into your computer.

If you place the files in a series of folders, the combined filename and folder path may become too long and the operating system may not allow you to open the files. To avoid this, it is recommended that you place data in your computer's C:\ folder.

- Copy the appropriate folder to the office computer using an application such as Windows[®] Explorer. This copies all the sub-folders and files in the folder.

Note – When you copy or move files using Windows Explorer, you must keep all the shape-files (.dbf, .shp, and .shx) together so that office software can open the theme file. To ensure that the files stay together, always copy the entire folder rather than just the individual files.

- If you create a new event in a field, and you already have the \Field\ folder containing any previous events on the office computer, you should still copy the \Field\ folder so that the new EventHistory information is copied.

Delete data



CAUTION – Deleting data is permanent. You cannot undo the deletion or restore the data.



If you need to create more space, you can use the FM-1000 Plus application to delete from the FM-1000 Plus application internal memory or the USB drive:

- Clients
- Farms
- Fields
- Events

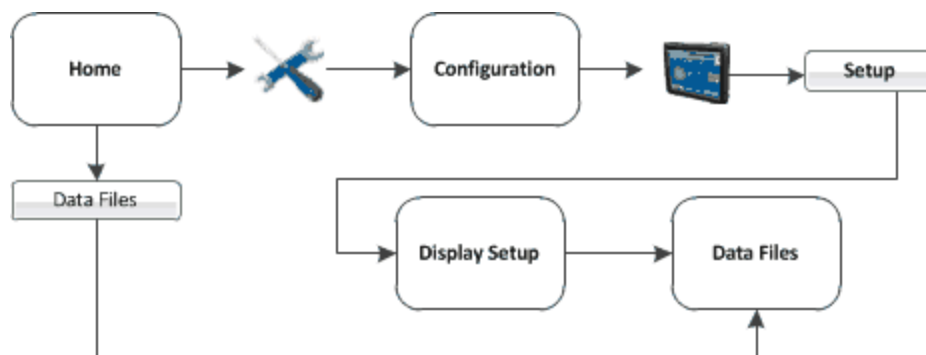
Note – You cannot undo data deletion or restore the data.



- At the *Data Files* screen, tap **Delete Data**. The *Delete Data Storage* screen displays.
- If you want to delete from:

- The internal memory of the FM-1000 Plus application: Tap the  Internal tab.
 - The USB drive: Tap the  USB Drive tab.
3. To delete a specific item from the FM-1000 Plus application:
 - a. In the lists for Client, Farm, Field or Event, tap the item you want to delete.
 - b. Tap **Delete**.
 - c. To exit the *Delete Data Storage* screen, tap **OK**.
 4. To delete all materials from the FM-1000 Plus application:
 5. To delete all events from the FM-1000 Plus application:
 - a. Tap **Delete All Events**.
 - b. Enter the administration password.
 6. To delete all files from the FM-1000 Plus application:
 - a. Tap **Delete EVERYTHING**.
 - b. Enter the administration password.
 7. The system displays a message asking you to confirm the deletion. If you want to proceed, tap **Yes**.

Data storage structure

The FM-1000 Plus application stores client, farm, field, and event data in a specific structure on the computer and USB drive. The first level folder is AgGPS.

Depending on your system configuration and the operations you perform, the top level folders of the structure are:

- [AB Lines folder \(page 101\)](#)
- [Archives folder \(page 102\)](#)
- [Autopilot folder \(page 102\)](#)
- [Data folder \(page 102\)](#)
- [Data Dictionary folder \(page 109\)](#)
- [Diagnostics folder \(page 109\)](#)
- [Prescriptions folder \(page 110\)](#)
- [Summaries folder \(page 110\)](#)
- [Task Data folder \(page 112\)](#)

AB Lines folder

There is one set of boundary and AB Line shapes for each field:

- **Boundary.*** - Fields with boundaries include a boundary polygon stored in the boundary.shp file. Fields without boundaries do not contain a boundary file.
- **Swath.*** - For fields with boundaries, AB polylines are stored in the swath.shp file.

Note – Units are always metric in files created by the FM-1000 Plus application.

The following is stored in the boundary and AB line attribute files.

Column	Field Description	Format
Area	Field area (Boundary area)	ha
Date	Date the field was created	YYYYMMDD
Dist1		
Dist2		
ID	AB Line number ID	
Length	Length of the AB Line	meters

Column	Field Description	Format
Name	Name assigned to the AB Line	
Perimeter	Field perimeter distance (Boundary only)	meters

The size of the field is not defined unless a field has a boundary. Therefore, the %_Complete in the EventHistory.dbf file is always zero for fields without boundaries

Note – If you browse the .dbf files using an Excel spreadsheet, date fields may appear in a different format, depending on your local settings. Unless a field has a boundary, the size of the field is not defined. Therefore, for fields without boundaries the %_Complete in the EventHistory.dbf file is always zero.

Archives folder

When the ProgramLog.txt file becomes larger than 1024 KB, it is backed up to a file named ProgramLog.old and stored in the Archives folder.

Autopilot folder

The Autopilot folder contains the following subfolders:

- Configuration
- Custom Vehicle Configurations
- VDB
- Vehicle Database

Data folder

The data folder contains the client subfolder and all subsequent subfolders related to the client.

Client subfolder

The client is the customer for whom the work is being done. This folder contains at least one Farm subfolder for each client.

Farm subfolder

A farm is a collection of fields. This folder contains at least one Field subfolder related to each farm.

Field subfolder

You create an on-screen field to represent an actual field, part of an actual field, or a group of more than one actual fields.

This folder contains an Event subfolder for each event performed on the field as well as the following files:

Data	Explanation	Files
Field AB Line	Boundary and/or AB Line polylines	Swaths.shp Swaths.dbf Swaths.shx
Field Boundary	Polygon (Only available if the field is a headland field and therefore has a boundary)	Boundary.shp Boundary.dbf Boundary.shx
Coordinates	Contains coordinates of the field boundary file	<Latitude Longitude Altitude>.pos
Paused Files	Information regarding guidance being paused	
Event history	Information about each event carried out in the field	EventHistory.dbf Version / Client / Farm / Field / Event / Operator / Material / Date Open / Time Open / Date Close / Time Close / Duration / Primary AB / ABLine / Cover Area / Cover Distance / Cover Time / Engage Time
Point features	Attribute ID and latitude, longitude, and height	PointFeature.shp PointFeature.dbf PointFeature.shx
Line features	Line with attribute ID	LineFeature.shp LineFeature.dbf LineFeature.shx
Area features	Area polygons with attribute ID	AreaFeature.shp AreaFeature.dbf AreaFeature.shx

Event History file

The EventHistory.dbf file contains information on every event carried out in the field.

Data	Explanation
ABLine	Guidance line used
Client	Client name
Cover area	Area covered
Cover distance	Distance covered
Cover time	Total time to cover the covered area
Date close	Date the field was closed
Date open	Date the field was opened
Duration	Length of time that the field was open (seconds)
Engage time	Time engaged
Event	Event name
Farm	Farm name
Field	Field name
Material	Material name
Operator	Operator name
PrimaryAB	Number of the primary AB Line
Time close	Time the field was closed
Time open	Time the field was opened
Version	FM-1000 Plus application firmware version

Data in features file

One row of data is stored in the <type>.dbf file for each feature of that feature type recorded in the field.

Data	Explanation	Format / Notes
Area	Field area (Area only)	ha
Date	Date the feature was created.	yyyy/mm/dd
Dist1		
Dist2		

Data	Explanation	Format / Notes
ID	Feature ID	
Length	Length of the AB Line.	meters
Name	Feature name	
Perimeter	Field perimeter distance (Area only)	meters
PrefWeight		
SwathsIn		
Time	Time the feature was recorded.	hh:mm:ss.s
Version	Features attribute file version.	

The following data is only recorded in point features.

Data	Explanation	Format / Notes
AlarmRad	Alarm radius	meters
Height	Ground mean sea level height at antenna position. If you are mapping on a slope, the height may be wrong.	meters
Latitude	Antenna latitude	decimal degrees
Longitude	Antenna longitude	decimal degrees
Status_Txt	GPS status	meters
WarningRad	Warning radius	meters

Event subfolder

An event is a precision agriculture application or activity on a particular field. For example:

- Planting of seed
- Application of fertilizer or lime
- Spraying with fungicide, herbicide, or insecticide

Files stored in this folder are:

Data	Explanation	Files
Coverage	Graphical files containing polygons	Coverage.shp Coverage.dbf Coverage.shx
Track	Graphical files containing a series of 3D points with attributes	Track3D_<date time>.shp Track3D_<date time>.dbf Track3D_<date time>.shx
Free Form Guidance	Graphical files containing paths for free form guidance	Swaths.shp Swaths.shx Swaths.dbf

Coverage logging file

The display creates a coverage logging file when any application coverage is recorded. For each coverage polygon, the following information is saved to the coverage logging file.

Data	Field Description
AppType	Application type ID
AppliedRate	Applied rate reported by the variable rate controller
DateClosed	Date the polygon was closed
GPS_Status	Numeric GPS status value
Height	Height in meters
Speed	Average GPS ground speed for the polygon (in meters per second)
Status_Txt	GPS status description
Swath	The current swath number when coverage was recorded
TimeClosed	Time the polygon was closed
Version	Coverage attribute file version
XTE	Implement Cross Track Error (in meters)

Track logging file

A track logging file is created whenever the event is opened. At each point, a number of attributes are recorded.

The units stored in the track attribute file (Track3D_<date time>.dbf) are in metric units.

Also see: [Map settings \(page 70\)](#).

Data	Field Description	Format / Notes
Along_Line	Along Line distance from start of swath	meters
Ant_HAE	Antenna height above ellipsoid	meters
Ant_Lat	Antenna latitude (WGS-84)	DD.dddddddd
Ant_Long	Antenna longitude (WGS-84)	DD.dddddddd
Appln_Width	Application width	meters
As applied	The actual rate applied by the rate control system when serial rate control, TAC or the Field-IQ system are used	
Auto_Steer	Auto-Steer Flag (1=on, 0=off)	On or off
Corct_Age	DGPS signal correction age	seconds
DOP	Horizontal Dilution of Precision – a measure of the quality of positions based on satellite geometry	–
Field_Name	Name of the field	–
GPS_Status	GPS status value	1 to 12
Ground_HAE	Ground height above ellipsoid	meters
Heading	Direction of travel with respect to true North.	decimal degrees
Height	Mean sea level height of ground	meters
Local_Time	Local time	hh:mm:ss.s
Logging_On	Coverage logging Flag (1=on, 0=off)	On or off
NDVI	The NDVI values recorded when using the GreenSeeker plugin (not currently implemented)	
Num_Stats	Number of GPS satellites	–
Offline	Offline distance from swath center line	meters
Pitch	The pitch	–
Relative_Height	Height	meters
Roll	The roll	–
Speed	GPS derived ground speed	kph
Status_Text	GPS status description	–

Data	Field Description	Format / Notes
Swath_Num	Current swath/headland number	
Swath_wdth	Swath width	meters
Target	Target rate at the current position	–
Target	Target application rate when serial rate control, TAC or the Field-IQ system are used	
Total_Qty	Total volume of material as applied for the current field Only supported for the: <ul style="list-style-type: none"> • Aerial Flow Controller • Autocal Flow controller • Crophawk Flow Meter 	–
TRACK_ID	Date and time stamp	–
Units	Units	metric
UTC_Date	Point creation date	YYYYMMDD
UTC_Time	UTC time	hh:mm:ss.s
Version	Track attribute file version	–
Yaw	The yaw	–

Graphical data formats

The FM-1000 Plus application uses the Environmental Systems Research Institute (ESRI) 3D shapefile format for storing the layers of graphical information collected in the field (for example, spray coverage, track logging points, and features). The three files in a shapefile set are:

- <filename>.dbf file: Contains the feature attributes
- <filename>.shp file: Contains position information
- <filename>.shx file: An index file that links the position information with its attributes

The term *shapefile* is used to refer to these three files collectively.

The FM-1000 Plus application records all latitude, longitude, and height data in decimal degrees.

Note – The FM-1000 Plus application reads and writes ESRI ArcView version 2.0 or 3.1 3D polylines, polygons, and points. The M and Z entity types introduced in ArcView 3.1 can be generated in the track logging files, but cannot be read by the display. For more information, visit the ESRI website (www.esri.com).

Graphical file editing

ESRI shape (.shp) and attribute (.dbf) files can be used in many other software packages that can import or use .shp and .dbf formats.

The Farm Works Software® is recommended. For more information, go to www.farmworks.com.

Data collected by the FM-1000 Plus application can be opened directly into the Farm Works software. You can make changes to the files and save them on an office computer.

The Microsoft Excel® spreadsheet software and most database software also let you open and view the data in the attribute (.dbf) file.

The FM-1000 Plus application can load files that you created in office software. Save Shapefile or Agfile (.gdx) prescriptions to the \AgGPS\Prescriptions\ folder on the USB drive to send rates to a variable rate controller.

Data Dictionary folder

The Data Dictionary folder contains text files you can add to customize the data dictionary. See [Data Dictionary categories \(page 112\)](#) and [Create / load a data dictionary \(page 113\)](#).

Diagnostics folder

Diagnostic logs are stored for the FM-1000 Plus application and XCN-2050 application activities. Logs are useful for Trimble Support to troubleshoot system operation issues.

The ProgramLog.txt file is saved in the Diagnostics folder and can be useful for troubleshooting. This file contains data from checks performed by the FM-1000 Plus application:

- When the display is turned on or off
- Periodically, while running

The file can be read with a text editor such as Notepad.

When this file becomes larger than 1024 KB, it is backed up to a file named ProgramLog.old and stored in the Archives folder. See [Archives folder \(page 102\)](#).

The Diagnostics folder contains the following subfolders:

- Autopilot (if you are using the Autopilot system)
- Preferences: System settings stored in the <Preferences>.xml file
- Screenshots: Screenshot files automatically numbered Screenshot_<num>.png
- gps
- logs
- Screenshots

Autopilot subfolder

This folder contains Autopilot configuration settings (vehicle.cfg).

Screenshots folder

The Screenshots folder contains screenshots you have captured.

System folder

The system folder contains log files used in troubleshooting.

Program log files

The ProgramLog.txt file can be useful for troubleshooting. This file contains data from checks performed by the FM-1000 Plus application:

- When the display is turned on or off
- Periodically, while running

When this file becomes larger than 1024 KB, it is backed up to a file named ProgramLog.old and stored in the Archives folder. See [Archives folder \(page 102\)](#).

The file can be read with a text editor such as Notepad.

Prescriptions folder

For each prescription that you generate, the system stores three prescription files in either of these formats:

- ESRI shape-file format:
 - <prescription_name>.shp
 - <prescription_name>.dbf
 - <prescription_name>.shx
- .gdx file format:
 - <prescription_name>.gdx

Some GIS software packages generate other files and include different contents in the files. If these files are on the USB drive, they are ignored when you transfer from the USB to the FM-1000 Plus application.

Summaries folder

The Summaries folder contains files such as:

- Program log files
- PDF summary file

PDF summary file

When you close a field, the FM-1000 Plus application creates a PDF summary file. This file is saved to the folder: \AgGPS\Summaries\

Event Details	
Event Number	0000-000-000-000000
Coverage Checked	0000-000-000-000000
Applied Rate	0000-000-000-000000
GPS Quality	0000
Average XTE Coverage Layer	0000
Event Date	0000-00-00
Event Time	00:00:00
Event Location	
Event Name	
Event Operator	
Event Vehicle	
Event Implement	
Event Status	
Event Notes	
Event Comments	
Event Summary	

Coverage Layers	
Layer 1	0000-000-000-000000
Layer 2	0000-000-000-000000

Equipment	
Vehicle	0000-000-000-000000
Implement	0000-000-000-000000
Implement Serial	0000-000-000-000000
Event Date	0000-00-00
Event Time	00:00:00

The Event Summary PDF file may include the following images of the field:

- Overlap: Coverage and any overlaps
- Height: Vertical height of the GPS position
- Applied rate: Volume at which the spray boom applied solution
- GPS quality
- Average XTE coverage layer: Degree of implement drift

The file also shows information about the:

- Event
- Vehicle setup

To view a summary report on a computer:

1. Remove the USB drive from the display.
2. Insert the USB into an office computer.
3. Select the folder \AgGPS\Summaries\.
4. Open the file Index.html.

Note – If you use the Microsoft® Internet Explorer® Internet browser, you may need to allow ActiveX® technology to see all of the summary file.

Task Data folder

The TaskData folder contains yield data collected in the ISO11783 BIN format, which is read by Farm Works and other precision agriculture software.

Data Dictionary categories

The data dictionary editor enables you to edit default data entry categories and add new ones.

Default data entry categories

The following are default categories in the Data Dictionary.

- Application method
- Client
- Crop
- Custom 1, 2, 3 and 4
- Event
- Farm
- Farm location
- Field
- Harvest
- Harvest year
- Implement
- Material
- Operator
- Operator EPA#
- Sky conditions
- Soil conditions
- Soil type
- Stoppage reason
- Target pests
- Vehicle
- Wind direction
- Wind gust speed
- Wind speed

Edit data entry categories

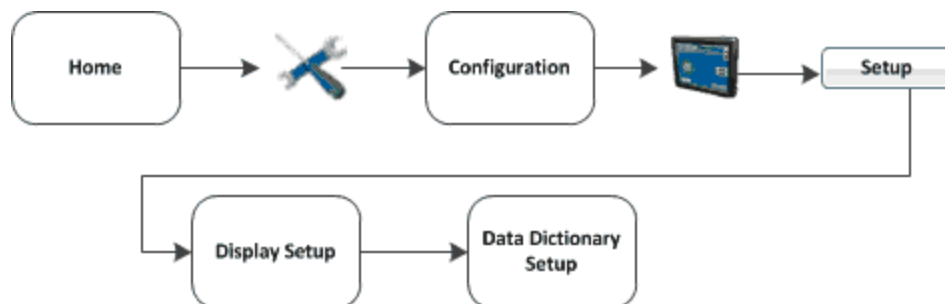

1. At the *Display Setup* screen, tap Data Dictionary.
2. Tap **Setup**. The *Data Dictionary Setup* screen displays.
3. From the data list, select the data item you want to add or change.

- Tap **New** to create a new item.
 - Tap **Edit** to change an existing item.
4. Define the custom entry by manually entering or updating the name, then tap **OK**.
 5. The new or edited entry displays in the data list on the *Data Dictionary Setup* screen.

Create / load a data dictionary

The FM-1000 Plus application can load data dictionaries that enable you to select field entry data (for example, Client, Farm, Field, and Event) from a list of predefined values. This saves you time from continually entering commonly used categories.

You can create a data dictionary either through the FM-1000 Plus application or using Farm Works software.

To create a data dictionary on a computer:

1. On a computer, create a text file. The text file can have any name, but the file extension must be .txt.
2. Enter the text.
3. Copy the .txt file to the \AgGPS\Data Dictionary\ folder on a USB drive.
4. On specific FM-1000 Plus application screens (for example, at the *Client* screen), the file entries will display.
5. To access the entries in the dictionary:
 - a. At the *Field Setup* screen, tap **New**.
 - b. Tap any list's down arrow to see the available items in the list.
 - c. Select the appropriate item from the list.
 - d. Tap **OK**.

Note – You can still enter new information as before, but these entries are not added to the data dictionary. To add items to the data dictionary, edit the .txt file on an office computer.

Connectivity settings

In this chapter:

GPS receiver settings	116
GPS output settings	133
Remote Output setup	136
Serial Data Input	142
Ag3000 modem	143
DCM-300 Modem	144

This chapter covers connectivity related to:

- GPS receiver settings, including corrections
- GPS output
- Serial data input
- Remote Output setup

GPS receiver settings

The FM-1000 Plus application automatically adds a GPS receiver option that controls the internal GPS receiver, when you install:

- Manual Guidance
- Autopilot
- FieldLevel II

In addition, the system may need second GPS receiver. For example, the TrueTracker system uses a second receiver that is configured with a separate GPS receiver option.

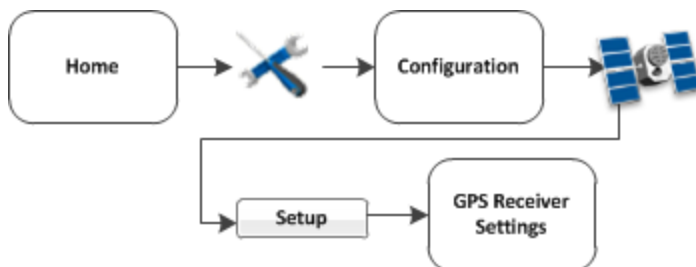

Note – GPS receiver settings will show different options, depending on how your system is setup.

Setup of the GPS receiver begins with corrections. The following corrections are available:

- Autonomous (no GPS corrections): WAAS and EGNOS
- CenterPoint™ RTK. See [CenterPoint RTK \(page 119\)](#).
- CenterPoint RTX™. See [CenterPoint RTX US or EU \(fs\) \(page 121\)](#).
- [CenterPoint RTX \(sc\) \(page 123\)](#)
- [CenterPoint RTX \(ss\) \(page 124\)](#)
- OmniSTAR® wide-area differential GPS service. See [OmniSTAR HP/XP/G2 \(page 128\)](#).
- [RangePoint RTX \(page 131\)](#)
- SBAS: Tracks DGPS correction systems using WAAS

AgRemote Interface

Note – Only advanced users should use the AgRemote interface.

The FM-1000 Plus application has an on-screen AgRemote interface for manually adjusting GPS receiver settings.

To access the on-screen AgRemote interface:

1. At the *Configuration* screen, tap  GPS Receiver and then tap **Diagnostics**. The *GPS Status* screen displays.
2. Tap **AgRemote**. The on-screen AgRemote interface displays.

For more information on the correct use of the AgRemote interface, refer to the *AgRemote Software Guide for AgGPS Receivers* on www.trimble.com.

Basic correction settings

For the basic corrections, complete the following steps.

1. At the *Configuration* screen, tap  GPS Receiver, then tap **Setup**. The *GPS Receiver Settings* screen displays.
2. On the Settings tab, from the Corrections list select either:
 - Autonomous
 - SBAS
3. On the Advanced tab, enter the settings.

Setting	Explanation
Elevation Mask	
SNR Mask	
RTK Base Station Filter	Enabled, Disabled
RTK Base Station CMR ID	Can be edited if Filter is enabled
Scintillation Filter	On or Off

4. On the Logging tab, if you want to record logs, select Record Logs.
5. On the Radar Output tab, enter the settings.

Setting	Explanation
Connector	TM-200 Port B connector P6 Radar output works for the EZ-Steer system or the Autopilot system.
Radar Frequency Rate	Enter Hz/mph rate

6. When you have completed the settings, tap **OK**.

CenterPoint RTK

Trimble CenterPoint™ RTK is radio-broadcast corrections from a ground-based reference station using either:

- Single-based line (CenterPoint RTK)
- Internet with a DCM-300 modem (CenterPoint VRS)

1. At the *Configuration* screen, tap  GPS Receiver, then tap **Setup**. The *GPS Receiver Settings* screen displays.
2. On the *Settings* tab, complete the settings.

Setting	Explanation
Antenna Selection	Select a supported antenna type
Corrections	Choose CenterPoint RTK
Net ID	
GPS Output	Tap to open the <i>GPS Output Settings</i> screen to send messages. See GPS output settings (page 133) .

3. On the *xFill* tab, enter the settings.

Setting	Explanation
x-Fill™ technology	On or Off During RTK signal interruptions, xFill technology can sustain RTK operation for up to 20 minutes.
Frequency	See Frequencies and baud rate (page 132) .
Baud Rate	See Frequencies and baud rate (page 132) .
Datum Selector	Choose the datum that was used when the RTK base station was surveyed. For more information contact your local reseller. Note – You must select the correct base datum for your location. If you select an incorrect value, this will result in incorrect xFill operation.

4. On the *SecureRTK* tab, enter the key or keys and an optional description.

The base station access code provided by your base station service provider. After you enter this code, the *Status* and *Expiry* values change to show the current status of the security feature.

SecureRTK is a Trimble proprietary base station security feature that enables a service provider with a RTK base station to generate time-based access codes for their supported rovers. If SecureRTK is enabled on the base station, rovers with authorized access codes can use corrections from that base.

SecureRTK requires firmware version 1.59, or later, on MS750™ GPS receivers, and firmware version 4.60 or later on AgRTK, AgGPS 442, and Ag GPS 542 base stations.

Note – Rovers without a SecureRTK access code are unable to access a secure Trimble RTK base station.

- On the Advanced tab, only alter the settings if directed by Support.

Setting	Explanation
Elevation Mask	
SNR Mask	
RTK Base Station Filter	Enabled, Disabled
RTK Base Station CMR ID	Can be edited if Filter is enabled
Scintillation Filter	On or Off

- On the Logging tab, if you want to record logs, select Record Logs.
- On the Radar Output tab, enter the settings.

Setting	Explanation
Connector	TM-200 Port B connector P6 Radar output works for the EZ-Steer system or the Autopilot system.
Radar Frequency Rate	Enter the required rate.

- When you have completed the settings, tap **OK**.

CenterPoint RTX US or EU (fs)

CenterPoint RTX™ (fs - fast satellite) is a satellite-based subscription correction service for the United States and European Union.

Note – Make sure you have unlocked the service before setting it up.

1. At the *Configuration* screen, tap  GPS Receiver, then tap **Setup**. The *GPS Receiver Settings* screen displays.
2. On the *Settings* tab, complete the settings.

Setting	Explanation
Antenna Selection	Select a supported antenna type
Corrections	Choose CenterPoint RTX US or EU (fs), depending on your region
GPS Output	Tap to open the <i>GPS Output Settings</i> screen to send messages. See GPS output settings (page 133) .

3. On the *Frequencies* tab, enter the settings for Frequency and Baud Rate. See [Frequencies and baud rate \(page 132\)](#).
4. On the *Advanced* tab, only alter the settings if directed by Support.

Setting	Explanation
Elevation Mask	
SNR Mask	
RTK Base Station Filter	Enabled, Disabled
RTK Base Station CMR ID	Can be edited if Filter is enabled
Scintillation Filter	On or Off

5. On the *Logging* tab, enter the settings.

Setting	Explanation
Record AgRemote Logs	Off or Record Logs

6. On the Radar Output tab, enter the settings.

Setting	Explanation
Connector	TM-200 Port B connector P6 Radar output works for the EZ-Steer system or the Autopilot system.
Radar Frequency Rate	Enter the required rate.

7. When you have completed the settings, tap **OK**.

CenterPoint RTX (sc)

CenterPoint RTX (sc - standard cell) is a satellite-based subscription correction service.

Note – Make sure you have unlocked the service before setting it up.

1. At the *Configuration* screen, tap  GPS Receiver, then tap **Setup**. The *GPS Receiver Settings* screen displays.
2. On the *Settings* tab, complete the settings.

Setting	Explanation
Antenna Selection	Select a supported antenna type
Corrections	Choose CenterPoint RTX (ss)
FastRestart	On or off FastRestart technology greatly reduces the time needed for OmniSTAR HP/XP/G2/VBS and CenterPoint RTX convergence. After the satellite signal has initially converged, you can turn off the receiver. When you turn the receiver on again, accuracy levels will be similar to those experienced before shutdown.
Convergence Threshold	Disabled
GPS Output	Tap to open the <i>GPS Output Settings</i> screen to send messages. See GPS output settings (page 133) .

3. On the *Logging* tab, if you want to record logs, select **Record Logs**.
4. On the *Radar Output* tab, enter the settings.

Setting	Explanation
Connector	TM-200 Port B connector P6 Radar output works for the EZ-Steer system or the Autopilot system.
Radar Frequency Rate	Enter the required rate.

5. When you have completed the settings, tap **OK**.

CenterPoint RTX (ss)

CenterPoint RTX (ss - standard satellite) is a satellite-based subscription correction service.

Note – Make sure you have unlocked the service before setting it up.

1. At the *Configuration* screen, tap  GPS Receiver, then tap **Setup**. The *GPS Receiver Settings* screen displays.
2. On the *Settings* tab, complete the settings.

Setting	Explanation
Antenna Selection	Select a supported antenna type
Corrections	Choose CenterPoint RTX (ss)
FastRestart	On or off FastRestart technology greatly reduces the time needed for OmniSTAR HP/XP/G2/VBS and CenterPoint RTX convergence. After the satellite signal has initially converged, you can turn off the receiver. When you turn the receiver on again, accuracy levels will be similar to those experienced before shutdown. Note – Do not move the vehicle from the point of system shut down. Otherwise this feature will not work.
Convergence Threshold	Disabled
GPS Output	Tap to open the <i>GPS Output Settings</i> screen to send messages. See GPS output settings (page 133) .

3. On the *Frequencies* tab, enter the settings for Frequency and Baud Rate. See [Frequencies and baud rate \(page 132\)](#).
4. On the *Advanced* tab, only alter the settings if directed by Support.

Setting	Explanation
Elevation Mask	
SNR Mask	
RTK Base Station Filter	Enabled, Disabled
RTK Base Station CMR ID	Can be edited if Filter is enabled
Scintillation Filter	On or Off

5. On the *Logging* tab, if you want to record logs, select Record Logs.

6. On the Radar Output tab, enter the settings.

Setting	Explanation
Connector	TM-200 Port B connector P6 Radar output works for the EZ-Steer system or the Autopilot system.
Radar Frequency Rate	Enter the required rate.

7. When you have completed the settings, tap **OK**.

OmniSTAR HP/XP/G2 - VBS

OmniSTAR VBS is a satellite-based subscription correction service delivered either by:

- Satellite
- Internet using a DCM-300 modem with <1.5" (3.8 cm) accuracy and GLONASS compatibility

Note – Make sure you have unlocked the service before setting it up.

1. At the *Configuration* screen, tap  GPS Receiver, then tap **Setup**. The *GPS Receiver Settings* screen displays.
2. On the *Settings* tab, complete the settings.

Setting	Explanation
Antenna Selection	Select a supported antenna type
Corrections	Choose OmniSTAR HP/XP/G2 - VBS
FastRestart	On or off FastRestart technology greatly reduces the time needed for convergence. After the satellite signal has initially converged, you can turn off the receiver. When you turn the receiver on again, accuracy levels will be similar to those experienced before shutdown. Note – Do not move the vehicle from the point of system shut down. Otherwise this feature will not work.
Convergence Threshold	Disabled
GPS Output	Tap to open the <i>GPS Output Settings</i> screen to send messages. See GPS output settings (page 133) .

3. On the *Advanced* tab, only alter the settings if directed by Support.

Setting	Explanation
Elevation Mask	
SNR Mask	

4. On the *Logging* tab, if you want to record logs, select **Record Logs**.

5. On the Radar Output tab, enter the settings.

Setting	Explanation
Connector	TM-200 Port B connector P6 Radar output works for the EZ-Steer system or the Autopilot system.
Radar Frequency Rate	Enter the required rate.

6. When you have completed the settings, tap **OK**.

OmniSTAR HP/XP/G2

OmniSTAR HP/XP/G2 is a high-accuracy, satellite-based subscription correction service. The accuracy for each type is:

- HP: 2-4" (5-10 cm) accuracy
- XP: 3-4" (8-10 cm) accuracy
- GP: 2-4" (8-10 cm) accuracy (compatible with GLONASS)

Note – Make sure you have unlocked the service before setting it up.

1. At the *Configuration* screen, tap  GPS Receiver, then tap **Setup**. The *GPS Receiver Settings* screen displays.
2. On the *Settings* tab, complete the settings.

Setting	Explanation
Antenna Selection	Select a supported antenna type
Corrections	Choose OmniSTAR HP/XP/G2
FastRestart	On or off FastRestart technology greatly reduces the time needed for convergence. After the satellite signal has initially converged, you can turn off the receiver. When you turn the receiver on again, accuracy levels will be similar to those experienced before shutdown.
Convergence Threshold	The required accuracy of the correction service before the signal will converge and the automatic steering system will engage.
GPS Output	Tap to open the <i>GPS Output Settings</i> screen to send messages. See GPS output settings (page 133) .

3. On the *Advanced* tab, only alter the settings if directed by Support.

Setting	Explanation
Elevation Mask	
SNR Mask	

4. On the *Logging* tab, if you want to record logs, select **Record Logs**.

5. On the Radar Output tab, enter the settings.

Setting	Explanation
Connector	TM-200 Port B connector P6 Radar output works for the EZ-Steer system or the Autopilot system.
Radar Frequency Rate	Enter the required rate.

6. When you have completed the settings, tap **OK**.

OmniSTAR VBS

OmniSTAR VBS is a satellite-based subscription correction service with 6-8" (15-20 cm) accuracy.

Note – Make sure you have unlocked the service before setting it up.

1. At the *Configuration* screen, tap  GPS Receiver, then tap **Setup**. The *GPS Receiver Settings* screen displays.
2. On the *Settings* tab, complete the settings.

Setting	Explanation
Antenna Selection	Select a supported antenna type
Corrections	Choose OmniSTAR VBS
GPS Output	Tap to open the <i>GPS Output Settings</i> screen to send messages. See GPS output settings (page 133) .

3. On the *Advanced* tab, only alter the settings if directed by Support.

Setting	Explanation
Elevation Mask	
SNR Mask	

4. On the *Logging* tab, if you want to record logs, select **Record Logs**.
5. On the *Radar Output* tab, enter the settings.

Setting	Explanation
Connector	TM-200 Port B connector P6 Radar output works for the EZ-Steer system or the Autopilot system.
Radar Frequency Rate	Enter the required rate.

6. When you have completed the settings, tap **OK**.

RangePoint RTX

Trimble RangePoint™ RTX is a satellite-based subscription correction service with pass-to-pass <6" (15 cm) accuracy and GLONASS compatibility.

Note – Make sure you have unlocked the service before setting it up.

1. At the *Configuration* screen, tap  GPS Receiver, then tap **Setup**. The *GPS Receiver Settings* screen displays.
2. On the *Settings* tab, complete the settings.

Setting	Explanation
Antenna Selection	Select a supported antenna type
Corrections	Choose RangePoint RTX
GPS Output	Tap to open the <i>GPS Output Settings</i> screen to send messages. See GPS output settings (page 133) .

3. On the *Frequencies* tab, enter the settings for Frequency and Baud Rate. See [Frequencies and baud rate \(page 132\)](#).
4. On the *Logging* tab, if you want to record logs, select Record Logs.
5. On the *Radar Output* tab, enter the settings.

Setting	Explanation
Connector	TM-200 Port B connector P6 Radar output works for the EZ-Steer system or the Autopilot system.
Radar Frequency Rate	Enter the required rate.

6. When you have completed the settings, tap **OK**.

Frequencies and baud rate

When you receive satellite signals, you must select the frequency and baud rate based on your specific region.

Region	Baud Rate
Western North America (RTX WN)	1557.8615 MHz at 600 baud
Central North America (RTX CN)	1557.8150 MHz at 2400 baud
Eastern North America (RTX EN)	1557.8590 MHz at 600 baud
South/Central America (RTX SA)	1539.8325 MHz at 600 baud
Europe/Africa (RTX EA)	1539.9525 MHz at 600 baud
Europe (RTX FS)	1529.7250 MHz at 2400 baud
Asia Pacific (RTX AP)	1539.8325 MHz at 600 baud

Note – These frequencies do change occasionally. If you experience issues with the satellite signal, contact your reseller for updated satellite information.

GPS output settings

To access the *GPS Output Settings* screen:

1. At the *Configuration* screen, tap  **GPS Receiver**, then tap **Setup**. The *GPS Receiver Settings* screen displays.
2. On the *Settings* tab, tap **GPS Output**. The *GPS Output Settings* screen displays. There are three tabs available:
 - [CAN GPS messages \(page 133\)](#)
 - [NMEA messages \(page 135\)](#)
 - [Serial NMEA messages \(page 134\)](#)

CAN GPS messages

You can set up specific messages to be sent from the GPS receiver from a CAN port. If you are using an ISO-certified implement, use this setting to send information to the implement (such as speed).

At the *CAN GPS* tab on the *GPS Output Settings* screen, complete the settings and tap **OK**.

Section	Setting	Explanation
Output	Port	The TM-200 CAN connection on Port A or Port B you want the GPS speed to be sent from
	Rate	How often you want the message to be sent
Simulated Speeds	Wheel Speed Port	The TM-200 CAN connection on Port A or Port B you want the wheel speed to be sent from
	Wheel Speed Rate	Off or On
	Radar/Ground Speed Port	The TM-200 CAN connection on Port A or Port B you want the radar/ground speed to be sent from
	Radar/Ground Speed Rate	Off or On

Serial NMEA messages

Note – Depending on your configuration, NMEA message output may require: Part number 67091, FmX to DE9, RS232 cable (Port A or B), Part number 59043, DB9(F) to DB9(F) modem cable.

Some GPS receivers can output serial NMEA messages to an external device. For example, if you have an external device connected to the Autopilot controller, you can have the receiver send GPS position information to the device. The messages are output through the NavController harness laptop connector.

Note – To enable NMEA output from another receiver for an optional feature, make sure the feature has been selected from the feature list.

At the Serial NMEA Messages tab on the *GPS Output Settings* screen, complete the settings and tap **OK**.

Setting	Explanation
Message Rate	How often the message is sent. Options are: <ul style="list-style-type: none"> • Off • 1 min • 30 sec • 10 sec • 1 Hz • 3 Hz • 5 Hz • 10 Hz
Output Port	What Serial port the message should be sent on Note – The output port may be on a EPX-100 typically assigned to Receiver EXP-100 or the Autopilot serial port.
Baud Rate	Baud rate. Options are: <ul style="list-style-type: none"> • 2400 • 4800 • 9600 • 19200 • 38400 • 57600
Maximum CGA Quality	How high the quality of the message should be
Lat/Lon Precision	Options are 1 through 10

NMEA messages

Some GPS receivers can output NMEA GGA type messages to an external device. For example, if you have an external device connected to the Autopilot controller, you can have the receiver send GPS position information to the device. The messages are output through the NavController harness laptop connector.

Note – To enable NMEA output from another receiver for an optional feature (for example, the GPS receiver connected to an TrueTracker system controller), make sure the feature has been selected from the feature list.

At the NMEA tab on the *GPS Output Settings* screen, complete the settings and tap **OK**.

Setting	Explanation
Message Rate	How often you want the message sent
Baud Rate	Baud rate
Messages Enabled	<p>On: Send NMEA message. Off: Do not send NMEA message. Message types supported are:</p> <ul style="list-style-type: none"> • CGA • VTG • GSA • GST • RMC • ZDA

Remote Output setup

When remote output is activated, the FM-1000 Plus application sends pulses to an external device. For example, you can use a remote output signal to control a tree planter.

To set up Remote Output:

1. Install Remote Output. See [Activate features/plugins for use \(page 60\)](#).
2. Set up Remote Output. See [Remote Output settings \(page 136\)](#).
3. Calibrate the lead time. See [Calibrate implement lead time \(page 139\)](#).

Remote Output settings

To enable pulse remote output:

1. Navigate to [Port settings \(page 74\)](#) and assign the EXP-100s to the first position or the second position.
2. At the *Configuration* screen, select  Remote Output and then tap **Setup**.
3. The *Remote Output* screen displays. Complete the settings and tap **OK**.
4. For Remote Output Connector:
Select the digital input/output connection assigned by EXP-100 #1 or EXP-100 #2.
See [Port settings \(page 74\)](#).
5. For Remote Output Type, choose the type:
 - a. For Time Based Pulse, enter:

Setting	Explanation
Time	The pulse interval in seconds
Duration	The pulse duration in milliseconds

- b. For Distance Based Pulse, enter:

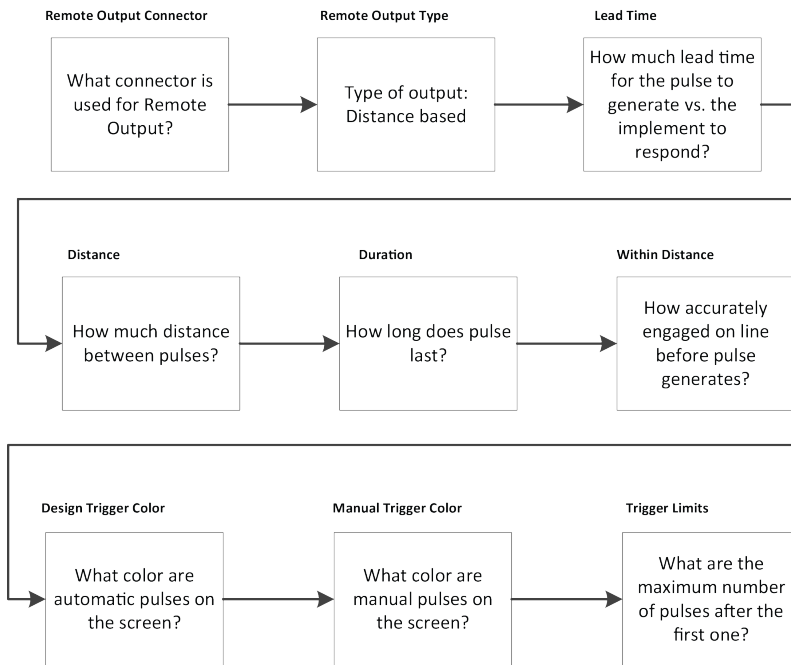

Setting	Explanation
Lead Time	See Calibrate implement lead time (page 139) .
Distance	The distance in meters/decimal feet/feet and inches. The pulse occurs at each increment of this distance. The first pulse occurs at the A point. Pulse remote output is not recommended for Headland patterns.
Duration	The duration of the pulse in milliseconds (ms)
Within Line Distance	The pulse occurs only when the vehicle is within this distance of being online. If the vehicle is more than this distance offline, no pulse occurs
Design Trigger Color	The color of the pulse indicator that will display on the screen when the system automatically outputs a pulse
Manual Trigger Color	The color of the pulse indicator that will display on the screen when you press the manual trigger button
Trigger Limits	If you select None, the pulses triggered by the system are unlimited. If you select Edit, enter the maximum number of pulses (per swath) that will be triggered after you pass the A point.

Note – This option works with straight AB and A+ lines.

For using remote output using distance based pulses, see [Distance-based pulse operation \(page 431\)](#).

- c. For When Within Area Feature, enter the Lead Time. Calibrate the Lead Time setting to match your implement. See [Calibrate implement lead time \(page 139\)](#). The pulse occurs only when Remote Output is enabled. You must also enable Remote Output for each area feature individually in the Mapping setup. See [Field feature use \(page 364\)](#).
- d. For When Engaged, there are no options to set. Remote output occurs when the system is engaged.
- e. For When Crossing a Line Feature, enter:

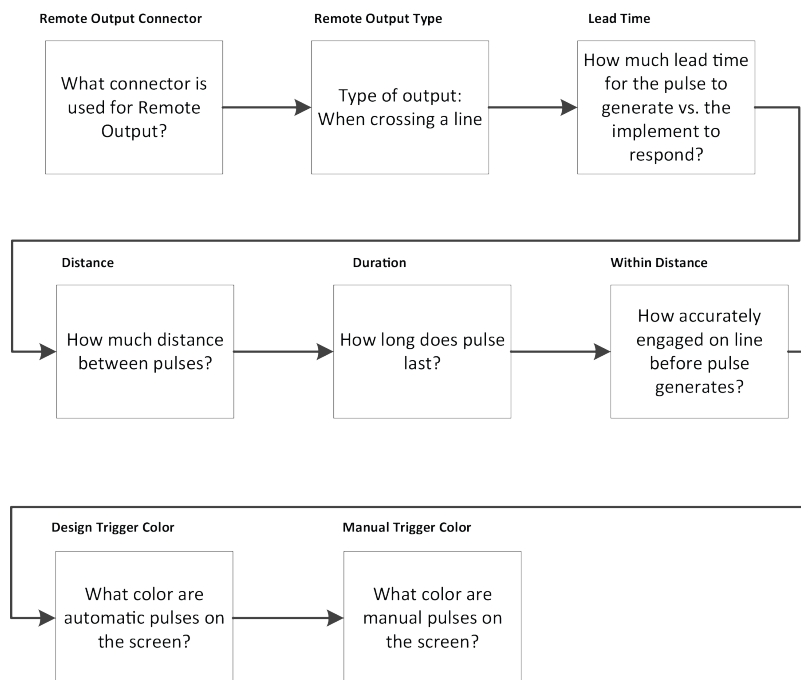

Setting	Explanation
Lead Time	See Calibrate implement lead time (page 139) .
Distance	The distance in meters/decimal feet/feet and inches. The pulse occurs at each increment of this distance. The first pulse occurs at the A point. Note – Pulse remote output is not recommended for Headland patterns.
Duration	The duration of the pulse in milliseconds (ms)

Setting	Explanation
Within Line Distance	The pulse occurs only when the vehicle is within this distance of being online. If the vehicle is more than this distance offline, no pulse occurs
Design Trigger Color	The color of the pulse indicator that will display on the screen when the system automatically outputs a pulse
Manual Trigger Color	The color of the pulse indicator that will display on the screen when you press the manual trigger button

Be sure to edit the line feature to enable remote output and the trigger warning. See [Line feature settings \(page 152\)](#). Complete the settings and tap **OK**.

Note – This option works with straight AB and A+ lines, pivots and curves.

For using remote output using when crossing a line feature, see [Crossing a line feature operation \(page 429\)](#).

6. Tap **OK** when your are finished.

Calibrate implement lead time

There is usually a gap between the time when the system generates a pulse and the time when that pulse triggers an action on the implement. To compensate for this system delay, you can set a lead time to trigger the pulse slightly early so that the action occurs at the correct location.

For this calibration, drive the vehicle along a line and back, using Remote Output to mark points on the ground. If the remote output is correctly calibrated, the points that you create when driving in both directions will be close together.

To calibrate implement lead time:

1. [Set front/back offset \(page 139\)](#).
2. [Calibrate front/back offset \(page 140\)](#).
3. [Set lead time \(page 140\)](#).

Set front/back offset

Configure the correct front/back offset.

1. Accurately measure either of these as appropriate:
 - Autopilot systems: The distance between the fixed axle of the vehicle and the part of the implement where the trigger marks will be applied on the ground.
 - Manual guidance systems: The distance between the antenna center-point and the part of the implement where the trigger marks will be applied on the ground.

2. At the *Configuration* screen, tap *Implement Setup*.
3. Enter the measurement as the F/B Offset distance on the *Implement Boom Setup* screen.

Calibrate front/back offset

1. Create a straight AB Line.
2. At the *Remote Output* screen, set the *Lead Time* to 0.
3. Drive as slowly as possible down the AB Line from point A to point B, marking points on the ground where the remote output triggers.
4. At the end of the line, turn the vehicle around.
5. Drive back down the line from point B to point A, marking another set of trigger points.
6. Measure the distance between the points from the first run and the points from the second run.
7. Divide the distance by two.
8. Adjust your *Front/Back Offset* value by this amount.
9. If the return points are nearer where you originally started than the first set of points, increase the F/B offset.
10. If the return points are further from where you originally started than the first set of points, lower the F/B offset.

Set lead time

1. Drive at your intended application speed down the AB Line from point A to point B, marking points on the ground where the remote output triggers. Ensure that your speed remains constant.
2. At the end of the line, turn the vehicle around.
3. Drive back down the line from point B to point A, marking the trigger points.
4. Measure any offset distance between the points from the first run and the points from the second run.
5. Divide the distance by two.
6. Convert your speed from mph to inches/second.
 $\text{Inches/second} = \text{mph} \times 17.6$
7. To calculate the lead time setting (in seconds), divide the distance between the points (in inches) from Step 5 by the vehicle speed (in inches/second).
 $\text{Lead Time} = \text{Half the distance between points (inches)} \div \text{speed (inches per second)}$
8. Enter the lead time at the *Remote Output* screen.
For example, if a 4 mph pass creates a 14" distance between each set of points:

- Divide the distance between the points by 2. (In this example, 14" / 2 = 7")
 - Convert the speed from mph to inches/second. (4 mph = (4 x 17.6) = 70.4 inches/second)
 - Divide the halved distance between the points by the speeds
7" divided by 70.4" per second = 0.999 Lead time in seconds
9. Drive along the AB line and then back at your application speed while you create trigger points.
 10. Ensure that the trigger points are sufficiently close to one another.
 11. If the gap between the points is unacceptable, repeat the calibrations.

Serial Data Input

Serial Data Input is an optional feature/plugin. When it is activated, the FM-1000 Plus application can receive and log NMEA messages from an external device (for example, an infra-red sensor).

1. Install Serial Data Input. See [Activate features/plugins for use \(page 60\)](#).
2. At the *Configuration* screen, select Serial Data Input and tap **Setup**. The *Serial Data Input* screen displays.
3. Complete the settings and tap **OK**.

Setting	Explanation
Port	The port the device is connected to. Usually an EXP-100 assigned to EXP-100#1 or EXP-100#2 used for serial communication on the Port settings (page 74) screen.
Baud rate	The rate information is transferred. Enter the appropriate rate for your region. See Frequencies and baud rate (page 132) .
Parity	
Data bits	
Stop bits	
Prefix	<p>The start point of the data you want to collect.</p> <ul style="list-style-type: none"> • To log data from the start of the line, leave this field empty. • To drop introductory characters, enter them. For example, if you receive data that begins with "\$GPGGA...", enter "\24GP" in this field. The data will then begin with "GGA...". ("\24" is the ASCII code for "\$".)
Suffix	<p>The end point of the data you want to collect.</p> <p>To log to the end of the line, keep the default field ("\0D\0A").</p>
Log Interval	How regularly the data is written to the file.

Ag3000 modem

The Ag3000 modem enables the FM-1000 Plus application to receive RTK corrections from a:

- Trimble VRS network
- Third-party RTK provider
- Continuously Operating Reference Station (CORS)

Modem activation

In the USA, the Ag3000 is bundled with a Trimble-installed AT&T card, which is tied to your Ag3000 unit and cannot be separated. You cannot use any other SIM cards with this device.

Additionally, the Ag3000 modem does not work in a CDMA network.

Outside of the USA, you must contact your local VRS Now™ or third-party cell provider for a SIM card.

Modem setup

Activate VRS for use. See [Activate features/plugins for use \(page 60\)](#).

1. At the *Configuration* screen, select VRS and then tap **Setup**.
2. The *VRS Configuration* screen displays.
3. Select the VRS Server Setup tab. Enter the required settings, as provided by your Trimble VRS Now™ or Network RTK operator.

Setting	Explanation
Server Name/Address	RTK/VRS/CORS base station broadcast name
Server Port Number	Base station port number
Mount Point	Base station mount point
User Name	Assigned username
Password	Assigned password

4. If you are inside the USA, tap **OK**. The *Configuration* screen displays. The Ag3000 modem is now configured.
5. If you are outside the USA, select the SIM Card Setup tab. Enter the details of the SIM card from the card provider, then tap **OK**.

DCM-300 Modem

The DCM-300 modem is a rugged and sealed 3G communications solution for customers who need reliable communications for their farming operations. This modem enables the FM-1000 Plus application to receive RTK corrections from a:

- Trimble VRS network
- Third-party RTK provider
- Continuously Operating Reference Station (CORS)

The benefits of using the DCM-300 modem include:

- More acres of RTK accuracy from Trimble VRS Now delivered to the FM-1000 Plus application.
- Easy interface and configuration with the FM-1000 Plus application.
- Roof-mounted high-gain cellular antenna for enhanced signal reception to minimize cell phone signal related drop outs.
- On-screen wireless status and diagnostics.
- Vehicle Sync
- Office Sync

The DCM-300 modem is available:

- With a HSDPA modem for use with GSM wireless networks globally
- An EVDO modem for use with the Verizon wireless network in the USA

Unlock the modem

The DCM-300 modem is available at different prices for Asset Tracking and VRS/File Transfer. The VRS/File Transfer functionality in the DCM-300 modem must be unlocked to use VRS or data transfer.

To unlock the DCM-300 with a passcode, you must connect the modem to the display and then turn it on. The *Unlock* screen shows the DCM-300 when connected.

Enter the passcode in the FM-1000 Plus application and then tap **OK** to send it to the modem. When the modem is successfully unlocked, a message displays to reboot the modem.

Service activation

Services for the DCM-300 modem can be purchased from a Trimble store. Services include:

- VRS Now Ag correction service
- Sync data transfer

- Dispatch asset tracking
- Wireless data plans (USA only)

Modem setup

Activate VRS for use. See [Activate features/plugins for use \(page 60\)](#).

To use VRS corrections, the GPS Setup tab must be configured with a Correction type of Trimble VRS.

Note – *The display must be unlocked for RTK to use the Trimble VRS correction type.*

1. At the *Configuration* screen, select VRS and then tap **Setup**. The *VRS Configuration* screen displays.
2. From the *Device* list, select the type of modem that is connected. The default is DCM-300.
3. Select the VRS Server Setup tab. Enter the required settings, as provided by your Trimble VRS Now or Network RTK operator.

Setting	Explanation
Server Name/Address	RTK/VRS/CORS base station broadcast name
Server Port Number	Base station port number
Mount Point	Base station mount point
User Name	Assigned username
Password	Assigned password

4. If you are inside the USA and:

Subscribe to the AT&T or Verizon data plans and have a DCM-300G modem, tap **OK**. The *Configuration* screen displays.

Supply your own SIM card and have a DCM-300G modem, enter the details of the SIM card from the card provider, then tap **OK**.

Note – *The DCM-300C modem for Verizon does not use the SIM card setup tab.*

Field feature mapping setup

In this chapter:

Field feature mapping settings	148
Mapping location setting	150
Recording with coverage	151
Field area feature settings	151
Line feature settings	152
Boundary feature settings	152
Point feature settings	154

You can place features on the screen that represent points, areas and lines in your field.

Field feature mapping settings

You can place field features in the field while driving to define on the screen points of interest or areas to avoid. There are three types of field feature:

- Point: A single point in the field, such as a tree
- Line: A straight or curved line in a field, such as a fence
- Area: An area of land, such as a pond

You can customize:

- Which features display on the Mapping Guidance panel at the *Run* screen
- The settings of each feature

Access Feature Mapping settings

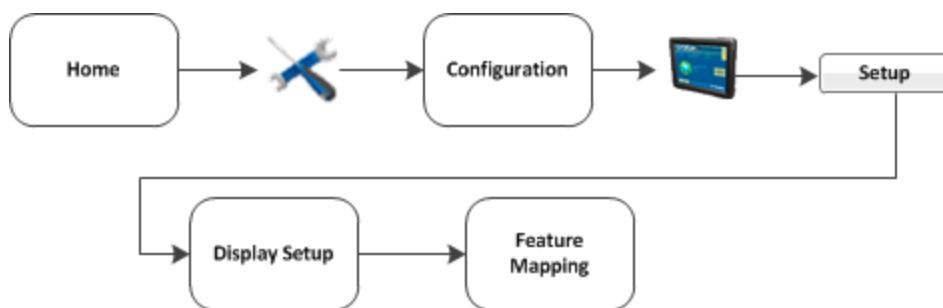

1. At the *Home* screen tap . The *Configuration* screen displays.
2. Select *System* and tap **Setup**. The *Display Setup* screen displays.
3. Select *Feature Mapping* and tap **Setup**. The *Feature Mapping* screen displays.

Assign feature buttons

To assign the feature buttons that will be available on the Mapping Guidance panel in the *Run* screen:

1. At the *Feature Mapping* screen, tap one of the four buttons under the *Selected Features* section. The *Select Feature* screen displays.
2. At the top left-hand list, choose the type of feature: *Area*, *Line* or *Point*. The options available to you for that feature type are listed below.
3. Select the feature option you want and tap **OK**.

Create a field feature

To create a feature in your field:

1. At the *Feature Mapping* screen, tap one of the four buttons under the **Selected Features** section. The *Select Feature* screen displays.
2. At the top left-hand list, choose the type of feature: Area, Line or Point.
3. Tap **New**. The *Edit Area/Line/Point Feature* screen displays.
4. Tap in the entry box for the name of the feature. The *Enter Area/Line/Point Feature Name* screen displays.
5. Enter the name of the feature and tap **OK**. You are returned to the *Edit Area/Line/Point Feature* screen.
6. Complete the settings for the feature you have added. For specifics, see:
 - [Field area feature settings \(page 151\)](#)
 - [Line feature settings \(page 152\)](#)
 - [Point feature settings \(page 154\)](#)
7. Tap **OK**. The *Feature Mapping* screen displays again, showing the button of the feature you just created.

Edit a field feature

To edit a feature you have placed in your on-screen field:

1. At the *Feature Mapping* screen, tap one of the four buttons under the **Selected Features** section. The *Select Feature* screen displays.
2. At the top left-hand list, choose the type of feature: Area, Line or Point.
3. Tap **Edit**. The *Edit Area/Line/Point Feature* screen displays.
4. To edit the name:
 - a. Tap in the entry box for the name of the feature. The *Enter Area/Line/Point Feature Name* screen displays.
 - b. Enter the name of the feature and tap **OK**. You are returned to the *Edit Area/Line/Point Feature* screen.
5. Edit the settings for the feature you have added. For specifics, see:
 - [Field area feature settings \(page 151\)](#)
 - [Line feature settings \(page 152\)](#)
 - [Point feature settings \(page 154\)](#)



6. Tap **OK**. The *Feature Mapping* screen displays again, showing the button of the feature you just edited.

Mapping location setting

As you place features in your on-screen field, they are placed in relation to the:

- Center of the boom
- Right of the boom
- Left of the boom



Access these settings at the *Feature Mapping* screen.

1. At the *Home* screen tap . The *Configuration* screen displays.
2. Select  System and tap **Setup**. The *Display Setup* screen displays.
3. Select Feature Mapping and tap **Setup**. The *Feature Mapping* screen displays.
4. Complete the settings for the Mapping Location section and tap **OK**.

Setting	Explanation
Point Features	Point features should be placed in your on-screen field relation to: <ul style="list-style-type: none"> • Boom Center: The center of the boom • Boom Right: To the right of the boom • Boom Left: To the left of the boom
Line/Area Features	Line and area features should be placed in your on-screen field relation to: <ul style="list-style-type: none"> • Boom Center: The center of the boom • Boom Right: To the right of the boom • Boom Left: To the left of the boom

Recording with coverage

You can choose to have line features be recorded when you have enabled coverage.

1. At the *Home* screen tap . The *Configuration* screen displays.
2. Select  System and tap **Setup**. The *Display Setup* screen displays.
3. Select Feature Mapping and tap **Setup**. The *Feature Mapping* screen displays.
4. From the Record Line with Coverage list, choose:
 - None: The line will not automatically record when you begin logging coverage.
 - As Applied:
 - Fence:
5. Tap **OK**.

Field area feature settings

You can use area features to define areas of land as productive or unproductive. If the sprayer passes into an area that is defined as unproductive, the boom sections turns off. This can be useful for setting exclusion zones that you do not want to spray (such as waterways).

Setting	Explanation
Name	Name of the feature
Color	Select the feature appearance color
Area Type	Productive: Choose this option if the area feature will be a section of land that can be included in area calculations. Non-productive: Chose this option if the area is unproductive land.
Trigger Warning	No Warning: No warning displays. Entering Area: A warning displays while you are inside the area. Leaving Area: A warning displays while you are outside the area.
Remote Output	Set to Enabled if a signal pin is attached to the system. This enables you to trigger a pulse to an external device when you enter or exit this area. See Remote Output setup (page 136) and Remote Output operation (page 429) .
Expand by	Options are:

Setting	Explanation
	<ul style="list-style-type: none"> • 1/2 swath width • 1 swath width

Line feature settings

1. At the *Feature Mapping* screen, tap one of the four buttons under the Selected Features section. The *Select Feature* screen displays.
2. At the top left-hand list, choose the Line feature.
3. Tap **New**. The *Edit Area/Line/Point Feature* screen displays.
4. Tap in the entry box for the name of the feature. The *Enter Area/Line/Point Feature Name* screen displays.
5. Enter the name of the line and tap **OK**. You are returned to the *Edit Area/Line/Point Feature* screen.
6. Complete the settings for the line:

Setting	Explanation
Color	Select the feature appearance color
Trigger Warning	Enabled: Warning is enabled Disabled: No warning will be issued
Remote Output	Set to Enabled if a signal pin is attached to the system. This enables you to trigger a pulse to an external device when you enter or exit this area. See Remote Output setup (page 136) and Remote Output operation (page 429) .

7. Tap **OK**. The *Feature Mapping* screen displays again, showing the button of the feature you just created.

Boundary feature settings

The FM-1000 Plus application includes the field boundary feature that enables you to map multiple-bounded areas within a field.

Field boundaries create a separate boundary file that can be used to calculate area and control automatic section switching at the edge of the field.

1. At the *Feature Mapping* screen, tap one of the *Selected Features* buttons. The *Select Feature* screen displays.
2. From the feature list, select *Area* and then tap **New**.
3. From the list of features, select *Boundary* and then tap **Edit**. The *Edit Area Feature* screen displays.
4. Set one or more of the following the attributes for the boundary features.

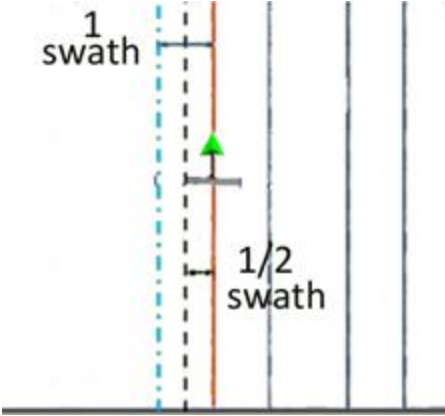
Setting	Explanation
Name	Custom name that displays on the Feature Mapping tab.
Color	Color of the boundary outline and also the infill color, if selected.
Draw as	Outlined or Filled
Trigger Warning	Visual and audible warning when entering or leaving the boundary edge.
Remote Output	Enabled: Restricts remote output pulses from being triggered while outside the boundary. Disabled: Does not restrict remote output. See Remote Output setup (page 136) .
Expand By	How the boundary is actually recorded: <ul style="list-style-type: none"> • Nothing: Maps the boundary exactly at the recorded position. • ½ Swath Width: Expands the recorded boundary location by ½ the swath width after the boundary is closed. • 1 Swath Width: Expands the recorded boundary location by 1 additional swath width after the boundary is closed. 

5. Tap **OK**. The *Select Feature* screen displays.

6. Tap **OK**. The *Feature Mapping* screen displays.
7. Tap **OK**. The *Display Setup* screen displays.
8. Tap **OK**.

Point feature settings

1. At the *Feature Mapping* screen, tap one of the four buttons under the Selected Features section. The *Select Feature* screen displays.
2. At the top left-hand list, choose the Point feature.
3. Tap **New**. The *Edit Area/Line/Point Feature* screen displays.
4. Tap in the entry box for the name of the feature. The *Enter Area/Line/Point Feature Name* screen displays.
5. Enter the name of the line and tap **OK**. You are returned to the *Edit Area/Line/Point Feature* screen.
6. Complete the settings for the point:

Setting	Explanation
Alarm Radius	<ul style="list-style-type: none"> • Displays as a solid red block when the vehicle comes within this radius of the feature • More serious than the warning radius. Set it to a shorter distance.
Warning Radius	<ul style="list-style-type: none"> • Distance around the feature that causes a warning message to appear • Displays on the screen as an orange line
Average Position	<p>Improves the quality of the point feature position</p> <ul style="list-style-type: none"> • Yes: The FM-1000 Plus application calculates the average position of the feature over 30 seconds. • No: The FM-1000 Plus application places the feature at the coordinates that the vehicle is at when you tap the button.

Implement setup

In this chapter:

Implement setup	156
Create an implement	157
Select an implement	157
Import an implement	158
Edit implement settings	158
Delete an implement	160

Before you can begin operations, you must select an implement that has been created and set up in the system.

Implement setup

Settings for an implement vary depending on the implement type and the operation it will be performing.

Implement setup ensures the system can tell:

- Which type of implement is attached
- How much area it covers
- How far offset the implement is from the guidance line or pattern

Note – *Some configuration settings are unavailable when a field is open in the Run screen. To access these settings, return to the Run screen and then tap the Home button. When prompted to close the field, tap **Close**.*

Create an implement

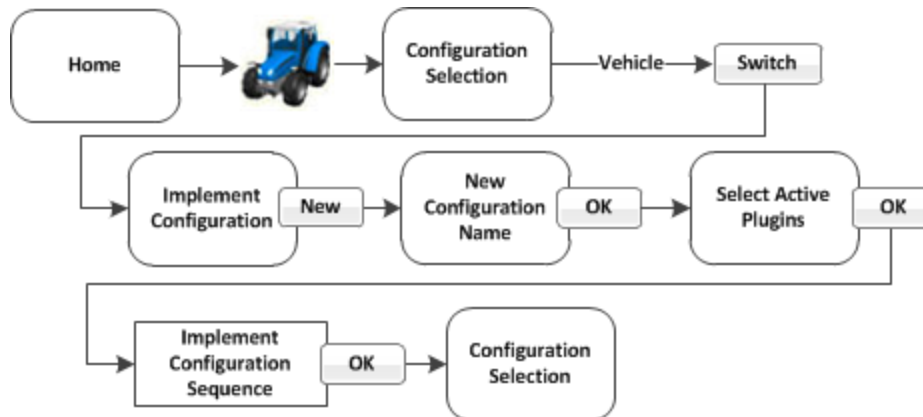

1. At the *Home* screen, tap .
 2. At the *Configuration Selection* screen, tap **Switch** next to the implement.
 3. If necessary, enter the administrative password. See [FM-1000 Plus application Passwords \(page 51\)](#).
 4. At the *Implement Configuration* screen, tap **New**.
 5. The *New Configuration Name* screen displays with an on-screen keyboard.
 6. Enter a name for the new implement and tap **OK**. The *Select Active Plugins* screen displays.
 7. Select the optional features/plugins that will be used with this implement and then tap **OK**.
 8. The *Implement Setup* wizard displays. See [Edit implement settings \(page 158\)](#) to complete the settings.
- Note** – The information needed for implement setup depends on the plugins that you selected in the previous step.
9. Tap **OK**. Your current configuration now displays in the *Configuration* screen.

Select an implement



To select an implement that has been configured:

1. At the *Home* screen, tap .
2. At the *Configuration Selection* screen, tap **Switch** next to the implement.
3. If necessary, enter the administrative password. See [FM-1000 Plus application Passwords \(page 51\)](#).

1. At the *Implement Configuration* screen, select the implement you want to switch to and then tap **OK**.
Note – If there is only one available implement, it is selected by default.
2. The currently selected implement is displayed in the *Configuration Selection* screen.

Import an implement

To import an implement:

1. Copy the implement file into the AgGPS folder on the USB drive.
2. Insert the USB drive into the FM-1000 Plus application and then turn on the display. Open the FM-1000 Plus application.
3. At the *Home* screen, tap .
4. At the *Current Configurations* screen, tap **Setup**.
5. If necessary, enter the Administration password. See [FM-1000 Plus application Passwords \(page 51\)](#).
6. At the *Configuration* screen, select  System and then tap **Setup**.
7. Select Data Files and then tap **Manage**.
8. Select Implement from the list on the left of the screen and then tap **Copy**.

The implements from the *FieldManager* screen now display in the *Implement Configuration* screen.

Edit implement settings

At the *Implement Setup* screen, you can change:

- **Implement Type**: Primary task for the current implement
- **Measurements**: Basic information required for guidance using an automatic steering system
- **Geometry**: More detailed implement dimensions required both with and without a GPS receiver on the implement
- **Overlap**: Values required to apply or avoid overlap
- **Switches**: Settings for switches tied to implement control system

Implement Type

In the *Implement Type* tab, choose the type of implement you want to set up.

Measurements

Note – The screen is scaled to the swath or application width, whichever is larger. If any offset is greater than this, the tractor image may pass the edge of the screen.

Note – This setting is used for navigation. At the Run screen, when you tap **Skip** to adjust the guidance line, the guidance line moves to the current location of the vehicle or can be moved by a user entered distance or number of rows. Row width is defined by the swath width divided by the number of rows.

Measurement	Explanation
Swath Width	Set the distance between guidance passes.
Application Width	The applied width of the tool or boom, which sets the width of the coverage logging and mapping.
Application Offset	Measured from the fixed axle of the vehicle to the point on the implement where coverage logging will be mapped. The fixed axle varies depending on vehicle type: <ul style="list-style-type: none"> • Rear axle on front steering tractor and self-propelled sprayer. • Front axle on a harvester and 4x4 tractor • Center of tracks on a tracked tractor
Rows	Number of rows that are covered by the implement.
Left/Right Offset	Measure from the center of the vehicle to the center of the implement or header. This measurement adjusts the tractor path so that an offset implement is centered on the guidance line.

Geometry

Set up the measurements required for accurate implement modeling.

Measurement	Explanation
Type	Select the implement type. The antenna offsets are required when a GPS antenna is mounted on the implement for TrueGuide and TrueTracker.
Hitch to Ground Contact Point	Measured from the tractor hitch pin to the soil engagement point that the implement rotates about. For planters this is typically the seeding units or the midpoint of several rows of tools

Note – For modeled implements, shortening this setting causes the implement to come online more quickly while lengthening the setting causes the implement to come online more slowly.

Overlap

When you map a headland, you create an inner boundary and an outer boundary. At this tab, set the Infill Boundary:

- Select **Inner** to shut off sections when the implement reaches the inner boundary.
- Select **Outer** to shut off sections when the implement reaches the outer boundary.

Switches

1. At the **Switches** tab, tap **Setup**.
2. At the *Add / Edit Implement Lift Sensor* screen, enter the appropriate settings.

Measurement	Explanation
Status	On: Select if you have one or more implement switches tied into your implements control system. Off: Select if you have no implement switches tied into your implements control system.
Number of Switches	Select the number of implement switches that you have tied into your implement control system.
Minimum Changed Switches	Enter the number of implement switches the system should recognize to determine if the implement is lifted.

Delete an implement

To delete an implement:

1. At the *Configuration Selection* screen, tap **Switch** next to the implement.
2. At the *Implement Configuration* screen, select the appropriate implement from the list.
3. Tap **Delete**.
4. When prompted, tap **Yes** to confirm the deletion.

Vehicle guidance setup

In this chapter:

Guidance settings	162
Manual guidance	162
Autopilot system	164
OnSwath settings	188
NextSwath settings	189
EZ-Pilot assisted steering system	199
EZ-Steer assisted steering system	205

Setup for vehicle guidance includes choosing the type of guidance system that your vehicle is configured for.

Guidance settings

- [Manual guidance \(page 162\)](#): For systems without any automatic steering system
- [Autopilot system \(page 164\)](#)
- [EZ-Pilot assisted steering system \(page 199\)](#)
- [EZ-Steer assisted steering system \(page 205\)](#)

All guidance systems require GPS. See [GPS receiver settings \(page 116\)](#).

For operational information, see:

- [Autopilot system operation \(page 402\)](#)
- [EZ-Pilot system operation \(page 416\)](#)
- [EZ-Steer system operation \(page 419\)](#)

Manual guidance

To set up manual guidance, complete the settings and complete the [GPS receiver settings \(page 116\)](#).

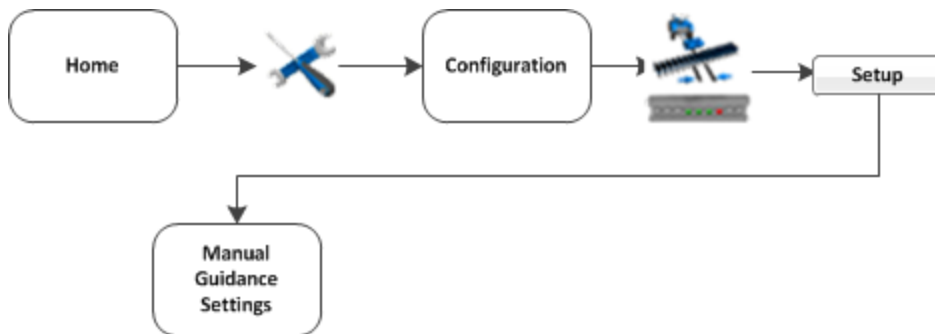

1. At the *Home* screen, tap . The *Configuration* screen displays.
2. Select Manual Guidance and then tap **Setup**. The *Manual Guidance Settings* screen displays.
3. In the *Vehicle* tab, complete the settings and tap **OK**.

Setting	Explanation
Vehicle Type	Type of vehicle
Axle to Antenna Offset	The horizontal distance between the axle and the antenna.

Setting	Explanation
	<p>Measure the distance accurately (within 3 inches). An incorrect offset may cause poor steering performance.</p> <p>Note – <i>Measure the offset distance as accurately as possible (within 3"); an incorrect offset may cause poor steering performance.</i></p> <ul style="list-style-type: none"> • If the antenna is in front of the axle, enter a forward distance. • If the antenna is behind the axle, enter a back distance.
Antenna Height	Measure the antenna height vertically, from the ground to the base of the antenna.
Wheelbase	The horizontal distance between the center of the front wheel and the center of the back wheel.

Note – Any changes you make to the vehicle settings remain, even if you replace the Manual Guidance option with the Autopilot option.

4. Complete the [GPS receiver settings \(page 116\)](#).

Autopilot system

Note – Autopilot system setup is typically done when the system is professionally installed.

For cabling information, see the *XCN-2050 Cabling Guide*.

For operational information, see [Autopilot system operation \(page 402\)](#).

The sequence of setting up the Autopilot system is:

1. Complete the [GPS receiver settings \(page 116\)](#) if you have not already done so.
2. Complete the settings for the Autopilot system.
3. Calibrate the Autopilot automated steering system for your vehicle. See [Autopilot calibration \(page 169\)](#).

Note – The subsequent configuration steps are usually done when the system is professionally installed.

Begin setup

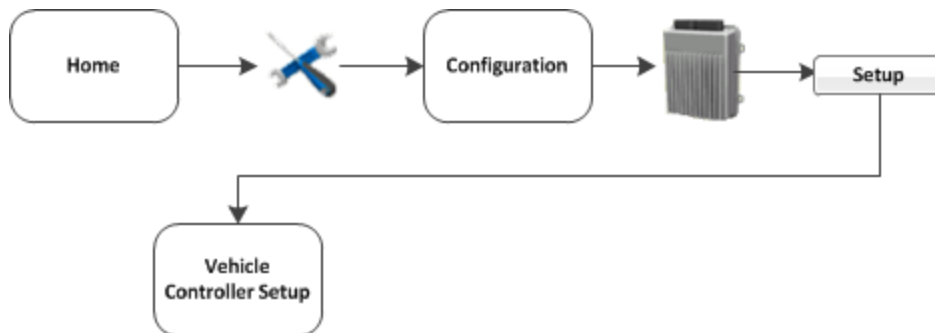

1. At the *Home* screen, tap . The *Configuration* screen displays.
2. Select Autopilot (Vehicle) and tap **Setup**. The *Vehicle Controller Setup* screen displays.

Vehicle settings for Autopilot system

Complete the settings in the *Vehicle* tab.



Setting	Explanation
Connector	Select Port A of the TM-200 Module.
Current Selection	Displays the current vehicle profile (.vdb) that is loaded. To change this setting, see Select a vehicle (page 168) .

Vehicle settings for Autopilot system

Complete the settings in the Vehicle tab.





Setting	Explanation
Connector	Select Port A of the TM-200 Module.
Current Selection	Displays the current vehicle profile (.vdb) that is loaded. To change this setting, see Select a vehicle (page 168) .

Engage settings for Autopilot system

At the Engage tab, complete settings related to the engagement of the Autopilot system.



Setting	Explanation
Operator Timeout	The amount of time of inactivity before an operator timeout message displays.
Coverage Log	How coverage logging occurs: <ul style="list-style-type: none"> • Manual: Coverage logging only occurs when you tap . • When Engaged: Coverage logging occurs when Autopilot steering is engaged, by tapping  (yellow). See Engage button (page 359).

Steering settings for Autopilot system

At the Steering tab, complete the settings related to steering on the guidance line.



Setting	Explanation
Nudge Increment	The distance the Nudge buttons in the <i>Run</i> screen move to for the vehicle to line up with the guidance line.
End of Row Warning Dist	The distance the vehicle is from the end of a row to trigger the end-of-row warning.
AutoSense	On or off. Note – Most recent Autopilot systems use an AutoSense device require this setting to be On.
Valve on Speed	<ul style="list-style-type: none"> • Normal: Speed threshold >0.4 m/s (1.3 ft/s). For normal operating speeds. • Low: Speed threshold >0.1 m/s (0.3 ft/s). For vehicles operating and very slow speeds. • Ultra Low: Speed threshold >0.2 m/s (0.7 ft/s). For vehicles operating and very slow speeds. Note – The NavController must have firmware version 5.10 or higher to support low and ultralow settings.
Legacy Sensors	For older Autopilot systems that use the electrical system to measure vehicle status. <ul style="list-style-type: none"> • None • Wheel Speed Only • Gear Level Only • Wheel and Gear This list is only available when AutoSense is set to Off.

Measurements for NextSwath

At the Measurements tab, complete the settings for using the NextSwath feature. See [NextSwath settings \(page 189\)](#) and [NextSwath operation \(page 405\)](#).

Vehicle Controller Setup

Vehicle
Engage
Steering
Measurements
Advanced

Setting	Explanation
Fixed Axle to Tow Hitch	Measure the distance from the center point of the drawbar hitch pin to the control point of the vehicle. Control points depend on the type of vehicle: <ul style="list-style-type: none"> MFWD: Rear axle Tracked tractor: Center of rotation Sprayer: Rear axle Combine/harvester: Front axle 4WD/articulated: Rear axle <p>Note – If you are using a 2-point hitch, measure from the fixed axle to the pivot point on the implement.</p>
Fixed Axle to 3-Point Hitch	Measure the distance from the rear axle of the vehicle to the location where the three point fixture attaches. Also use this measurement for fixed applications such as harvesting and spraying with a self-propelled sprayer.

Advanced settings for Autopilot system



Advanced settings are located in the Advanced tab. For more information regarding the Advanced tab settings, contact your local reseller.

Vehicle Controller Setup

Vehicle
Engage
Steering
Measurements
Advanced

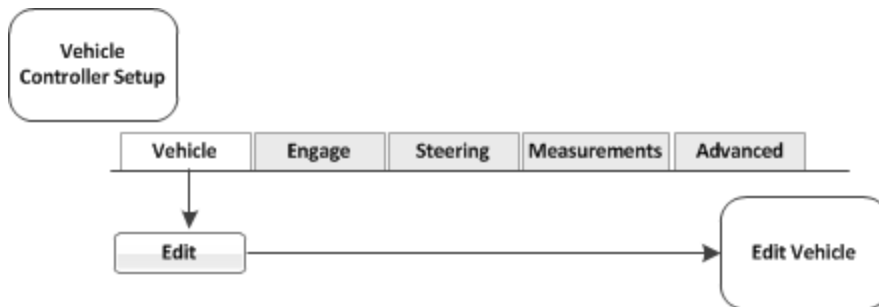
Select a vehicle



1. At the *Home* screen, tap . The *Configuration* screen displays.
2. Select  Autopilot (Vehicle) and tap **Setup**. The *Vehicle Controller Setup* screen displays.
3. Tap **Edit**. The *Edit Vehicle* screen displays.
4. From the Vehicle Profile Location list, select the source of the pre-configured vehicle profile you want:
 - Autopilot **controller**: The majority of vehicle profiles are stored on the Autopilot controller.
 - Vehicle profile **database** file: As additional profiles become available or are updated, they are added to a vehicle profile database. You can download the database and load profiles from it.
 - **Saved file**: You can install an individual vehicle profile that you configured previously and saved. See [Save vehicle profile \(page 186\)](#).

For Vehicle Profile Location, if you choose...	Then...
From Controller (New)	<ol style="list-style-type: none"> a. From the Model list, select the make and model you want. b. Tap Use Vehicle.
From Database (new)	<ol style="list-style-type: none"> a. Tap Browse. b. Select the .vdb file you want. c. Tap OK. d. Tap Use Vehicle.
From Saved File (existing)	<ol style="list-style-type: none"> a. Tap Browse. b. Select the file you want.

For Vehicle Profile Location, if you choose...	Then...
	<p>c. Tap OK.</p> <p>d. Select Save Vehicle to save the new settings.</p> <p>e. When a message displays that the profile you selected on the NavController, tap OK.</p> <p><i>Note</i> – If you select a vehicle make and model but do not upload that configuration to the Autopilot controller, that make and model may not be loaded.</p> <p>f. Tap OK when another message displays explaining the NavController will be reinitialized.</p>

Autopilot calibration

After you configure the vehicle make and model, calibrate the system for your vehicle. The calibration process records additional details about your vehicle which helps the system to steer the vehicle more accurately. For high accuracy systems, all settings must be correct.

All vehicle types

Four calibration items are required for all types of vehicles:

- [Controller orientation \(page 170\)](#): Correctly associates the outputs of the Autopilot controller sensors with the direction of the vehicle.
- [Manual Override Sensitivity calibration \(page 171\)](#): Required for platforms that employ a pressure transducer for the manual override function. Change the default only if the operation of the manual override function is acceptable.
- [Roll / antenna compensation calibration \(page 177\)](#): Compensates for antenna height and static roll caused by minor variations in the Autopilot controller and the GPS receiver mounting.
- [Line acquisition aggressiveness calibration](#): How aggressively the vehicle approaches the guidance line

Articulated and front-wheel-steered types

For articulated and front-wheel-steered vehicle types, additional calibrations are required:

- [Steering angle sensor calibration \(page 172\)](#): Converts the sensor output into commands for steering full left, full right and any position in between.
- [AutoSense calibration \(page 172\)](#): Orients Autosense.
- [Automated Deadzone calibration \(page 173\)](#): Required to learn the vehicle's steering deadzone.



- [Proportional steering gain calibration \(page 175\)](#): Required only if system steering performance is not satisfactory.

Tracked tractors

For tracked tractors, there are several calibrations required. See [Tracked tractor calibrations \(page 183\)](#).

Begin calibration



1. At the *Home* screen, tap .
2. At the *Configurations* screen, tap **Setup** next to the vehicle.
3. Select  Autopilot (Vehicle) and tap **Calibrate**. The *Vehicle Calibration* screen displays.
4. Select a calibration and tap **OK**.

Controller orientation

1. At the *Vehicle Calibration* screen, select **Controller Orientation** and tap **OK**. The *Autopilot Controller Orientation* screen displays. A graphic of the controller represents the current mounting orientation of the controller.

The image is shown as though:

- You are looking down on the vehicle from above.
 - The top of the screen points to the nose of the vehicle.
2. Use the buttons to select the orientation of the controller.
- If the controller is set at a sloped angle, the vehicle profile will set the NavController orientation.
- Note** – Install the NavController as described in the vehicle install instructions. If custom angles are used, the on-screen image of the controller does not display.
3. Tap **OK** to accept the new orientation or tap **Cancel** to exit.

Manual Override Sensitivity calibration



WARNING – Incorrect adjustment of the Manual Override Sensitivity calibration setting could cause this critical safety feature to fail, resulting in personal injury or damage to the vehicle. Any adjustment to this setting must be made only by an authorized dealer.

Note – *Manual Override Sensitivity calibration is valid only for platforms that employ a pressure transducer for the manual override function. The software automatically detects whether or not the vehicle configuration includes this type of sensor and provides this option if required.*

Manual override is one method of disengaging the Autopilot system by turning the steering wheel. When you turn the steering wheel, there is a voltage spike that then tapers off. This spike and decline occurs at different levels for different models of tractor.

The manual override sensitivity is the level that the voltage must spike to before the override occurs and the system disengages. The voltage must also taper below that level before automated steering can be engaged again. If you set a:

- High level of sensitivity, the system will disengage more quickly and you will have to wait longer before you can re-engage.
- Low level of sensitivity, the system will take longer to disengage and you will be able to re-engage more quickly.

Incorrect adjustment of the Manual Override Sensitivity calibration setting could cause this critical safety feature to fail, resulting in personal injury or damage to the vehicle. Any adjustment to this setting must be made only by an authorized dealer.

We strongly recommend that you perform this calibration only if the default sensitivity is unacceptable under all conditions. **Do not to choose a sensitivity setting that is either too sensitive or not sensitive enough.** In either case, manual override may cease to function correctly. On some platforms, you could set the sensitivity so low that the manual override function will not detect any steering wheel motion. It is vital that you avoid this.

Calibration steps

1. At the *Vehicle Calibration* screen, select Manual Override and tap **OK**. The *Autopilot Manual Override Calibration* screen displays.
2. Test the current manual override setting. Turn the steering wheel. The **Override Inactive** button changes color when the Override becomes active. With the system active, assess whether the manual override feature is at an acceptable level of sensitivity for:
 - Speed of steering wheel turn
 - Distance of steering wheel turn
3. To adjust the manual override sensitivity setting, move the slider bar.

Slider Bar Direction	Sensitivity is...	Manual Override is triggered...
Left	Increased	More easily
Right	Decreased	Less easily

The value above the slider bar on the right is the current setting. The total range of the slider bar is 0.5 to 2.5 (where 0.5 is the most sensitive setting and 2.5 is the least sensitive).

4. To try the new setting, tap **OK**. The *Vehicle Calibration* screen displays.
5. Select **Manual Override** again. The *Autopilot Manual Override Calibration* screen displays again.
6. Repeat steps 1 through 4 to test each new setting.

Note – You can also evaluate the performance of the manual override feature under conditions of loading and/or activities which may affect the pressure of the hydraulic system. For example, you can turn on the auxiliary hydraulics while you evaluate the manual override sensitivity.

7. Tap **OK** to accept the new setting or tap **Cancel** to exit.

AutoSense calibration

1. At the *Vehicle Calibration* screen, select **Autosense Calibration** and tap **OK**. The *Autopilot AutoSense Calibration* screen displays.
2. From the **Location** list, select the AutoSense position.
3. From the **Orientation** list, select the AutoSense orientation.
4. Tap **OK** to confirm selections.

Steering angle sensor calibration

Note – Perform the steering sensor calibration only if a rotary potentiometer is installed on the vehicle. If an AutoSense device is selected as the steering angle sensor, the *Steering Sensor* screen does not appear.

Steering sensor calibration converts the voltage output of the steering sensor into an equivalent steering angle measurement.

Note – Complete this calibration before you attempt to calibrate the steering deadzone or roll correction procedures.

This calibration requires the vehicle to be in motion. Ensure that you:

- Perform this procedure on a hard, level surface that is free of obstructions.
- Maintain a tractor speed above 1.6 kph (1 mph).
- Watch the **Sensor Angle** value:
 - For a symmetrical angle reading at the steering extremes while you manually steer the wheels to full right and full left

- To ensure that the angle reading is near zero while you manually steer the wheels straight ahead

Calibration steps

To run the steering sensor calibration:

1. At the *Vehicle Calibration* screen, select **Manual Override** and tap **OK**. The *Autopilot Steering Sensor Calibration* screen displays.
2. Move the tractor forward slowly.
3. Center the steering wheel and then tap **Next**.
4. Turn the steering wheel completely to the left and then tap **Next**. If the steering wheel is not turned completely to the left or if the steering sensor requires adjustment or replacement, an error message displays.

The value for **Volts** updates as you turn the steering wheel:

5. Turn the steering wheel completely to the right and then tap **Next**. If the steering wheel is not turned to the full right position or if the steering sensor requires adjustment or replacement, an error message displays.
6. At the next screen, center the steering wheel. While the wheel is at the center position, tap **Next**. The value for **Volts** updates as you turn the steering wheel.
7. Tap **OK** to accept the calibration.

Automated Deadzone calibration



WARNING – During the Automated Deadzone calibration, the system moves the wheels that steer the vehicle. To avoid injury, be prepared for sudden vehicle movement and that the area around the vehicle (and implement, if applicable) are clear.



WARNING – Obstacles in the field can cause collisions, which may injure you and damage the vehicle. If an obstacle in the field makes it unsafe to continue the Automated Deadzone calibration, stop the vehicle and turn the steering wheel to disengage the system.

- 1) Wait until the display prompts you that the phase is ready to begin.
 - 2) Look at the screen to determine whether the next phase will require a left or right turn.
 - 3) Reposition the vehicle so that the turn will use the space that you have available.
 - 4) Tap the button to begin the next phase.
-

The Automated Deadzone calibration runs a series of tests on the valve and steering hydraulics to determine the point at which steering movement occurs.

In this test, the system independently opens and closes each side of the steering system while determining the point at which wheel movement occurs.

- You must complete the Steering Angle procedure before you run this procedure.
- To ensure optimal system performance, the hydraulic fluid must be at normal operating temperature when you run this procedure. On some vehicles with large reservoirs, it may take several hours for the fluid to reach operating level, especially if the implement circuit is lightly loaded. Consult the vehicle documentation to determine if the hydraulic fluid temperature can be shown on a vehicle console.
- If you perform the calibration while the system is still cold, repeat both the Deadzone and the Proportional gain calibration procedures after the system is at operating temperature.

Calibration steps

Place the vehicle in a large field that is free of hazards. To minimize the effect of the ground conditions, the field should have smooth soil that is loose but firm.

At the *Vehicle Controller Setup* screen, select Automated Steering Deadzone and tap **OK**. The *Autopilot Automated Deadzone Calibration* screen displays.

1. Tap **Next**.
2. Tap **Next** in the two screens that display.
3. Follow all instructions. Tap the **Test Right** and **Test Left** buttons to perform the Deadzone calibration.
4. As ground conditions affect the results of this calibration, it is recommended that you perform the calibration at least three times, or until the average deadzone values change by less than about 0.5.

To minimize the total amount of space needed for the complete calibration, you can reposition the vehicle between the phases of the test. If the available flat, smooth space is extremely limited, re-align the vehicle after each segment of the calibration.

To reposition the vehicle:

- a. Wait until the software prompts you that the next phase is ready to begin.
 - b. Look at the screen to determine whether the next phase will require a left or right turn.
 - c. Reposition the vehicle so that the turn will use the space that you have available.
 - d. Tap the button to begin the next phase.
5. Reposition the vehicle and continue from the current test phase.

Automated Deadzone error messages

Error -	Explanation
Manual Override Detected	Manual override was detected before the calibration cycle could be completed. Retry.
Vehicle Moving Too Slow	The vehicle was moving too slowly for the calibration

Error -	Explanation
	cycle to successfully finish. Make sure the vehicle is moving at least 0.8 kph (0.5 mph) during each calibration cycle.
Steering Close To End Stops	Before the calibration cycle could be completed, the measured steering angle approached the end stops. Retry, and if the problem persists, instead of centering the steering at the start of each cycle, try turning the steering in the opposite direction to that which is being tested so that the calibration procedure has a greater range to test over.
Valve Connectors Could Be Swapped	The calibration test sensed the steering turning in the opposite direction to what was expected. Retry, and if the problem persists either the valve connectors have been accidentally swapped or the steering sensor calibration was performed incorrectly.
No GPS	A GPS receiver must be connected and outputting positions before the software can run the calibration procedure.
No Steering Response Detected	During the calibration cycle, insufficient movement was sensed for the calibration to complete. If the problem persists, the hydraulic installation could be faulty.
Unable To Determine DZ: Try Again	A problem occurred when trying to compute dead zone. Retry, and if the problem persists, contact Technical Support.
Software Problem Detected	The software was unable to complete the calibration due to insufficient movement of the vehicle. If the problem persists, contact Technical Support.

Proportional steering gain calibration



WARNING – The wheels can move abruptly during the Proportional Steering Gain procedure while the Autopilot system tests the hydraulic response to the steering commands. These sudden movements can cause collisions with nearby obstacles or cause injury to occupants of the vehicle. Be prepared for sudden wheel movements.

Note – Complete the steering sensor calibration **before** you perform the proportional gain calibration. Perform the proportional steering gain calibration **only** when the Autopilot system performance is less than satisfactory.

The Proportional Steering Gain (PGain) setting enables a balance between rapid steering response and stability. When you modify the PGain setting, two steering characteristics are affected:

- Slew Time: The amount of time that the front wheels take to move from the far left to the far right position and vice versa.
- Overshoot: The percentage by which the front wheels exceed the commanded angle before they settle on the correct value.

To correct slight variations caused by valve current response, friction, and hydraulic fluid viscosity, alter the PGain value:

- High PGain value: Decreases the slew time and increase the overshoot. This provides rapid responses, but can cause the steering to exhibit signs of instability (for example, a tendency to excessively overshoot).
- Low PGain value: Increases the slew time and decrease the overshoot. This improves the stability but can introduce significant delays in the steering response and can cause the vehicle to oscillate from side to side.

Perform the calibration:

- Immediately before you run the PGain calibration, even if the Automatic Deadzone calibration has been performed in the past.
- On a hard, level surface that is free of obstructions.
- While maintaining a vehicle speed above 1.6 kph (1 mph)

Increase the proportional gain up to the point just before any one of the following occurs:

- Slew times no longer decrease (a low value is required)
- Overshoot exceeds 5 – 8% (depending on the vehicle)
- Wheels noticeably shake near end stops

Calibration steps

1. At the *Vehicle Calibration* screen, select *Steering Gain* and tap **OK**. The *Autopilot Steering Gain Calibration* screen displays.
2. Tap **Run Slew Test**. A warning message displays.
3. Tap **Next**.



WARNING – The wheels can move abruptly during the Proportional Steering Gain procedure while the Autopilot system tests the hydraulic response to the steering commands. These sudden movements can cause collisions with nearby obstacles or cause injury to occupants of the vehicle. Be prepared for sudden wheel movements.

4. Tap **Next** in the next two screens that display.

5. Test various gain settings while you monitor the vehicle performance and the values for Slew Time and Overshoot for the Turn Left phase.
 - a. Adjust the New Gain (if required).
 - b. Turn the front wheels completely to the right to begin the test. (The test is for the stop-to-stop position.)
 - c. Tap **Turn Left**. Both turn buttons are unavailable while the wheels slew.

***Note** – The optimum gain setting has short slew time (short millisecond reading) and low overshoot percentage (less than 5–8%).*
6. Repeat Step 5 with **Turn Right**. Both turn buttons are unavailable while the wheels slew.
7. When you locate the best gain value, either:
 - Tap **OK** to save the value in the Autopilot controller memory.
 - Tap **Cancel** to restart the calibration procedure.

Roll / antenna compensation calibration

***Note** – Antenna offsets are provided when the antenna cannot be placed directly over the working point of the implement. It is recommended that these offsets are minimized whenever possible.*

At the *Vehicle Calibration* screen, select Roll/Antenna Correction and tap **OK**. The *Autopilot Roll/Antenna Compensation* screen displays.

Precalibration

Before configuring the antenna compensation, make sure that:

- The Autopilot system is completely and correctly set up.
- GPS corrections are set up.
- You read this section carefully.
- If multiple GPS technologies will be used (for example, RTK and SBAS), use the technology with the highest accuracy when you perform the Roll Correction calibration.

Calibration steps

1. Set the antenna height above the ground.
 - a. Place the tractor on a flat, level surface.
 - b. Measure the distance from the ground to the base of the GPS receiver (or antenna).
 - c. Enter this value for Antenna Height Above Ground.

2. Set the antenna distance from the fixed axle.
 - a. Place the tractor on a flat, level surface.
 - b. Measure the distance from the fixed axle to the center of the GPS receiver (or antenna).
 - c. Enter this value into the Antenna Distance from Fixed Axle entry box. Enter a negative value if the GPS receiver antenna is to the rear of the fixed axle. The nose of the vehicle is considered the forward direction.
3. Configure the roll offset correction.

Use one of the following methods to calculate the roll offset and then enter the roll offset correction to compensate for it:

 - [Tire track offset method](#)
 - [Flag offset method](#)

Choose the method which best matches the conditions.
4. Enter the roll offset value for roll offset.
5. Select one of the offline direction options, depending on whether the roll offset distance is to the right or left.

Tire track offset method for roll offset

Note – Use a highly repeatable GPS correction mode for roll correction. For best results, use a RTK mode or OmniSTAR HP signal that has been converged for at least twenty minutes. If you do a roll calibration with less accurate GPS correction modes, repeat the measurements **at least four times** to ensure a more consistent result.

1. Remove any implement from the vehicle.
2. Drive the tractor to a relatively flat field where tire impressions are visible and where you can complete passes of at least 400 m (1320 ft) in length.
3. Reset the roll offset value to 0 (zero).
4. Create an AB Line.
5. Create a clean set of tire tracks in the field. To do this, start a new pass away from the area where the AB Line was created. When the system is stable, engage automatic steering mode and allow the Autopilot system to complete the pass.
6. At the end of the pass, turn the tractor around to return along the same pass from the opposite direction.
7. Engage automated steering mode and allow the system to complete the pass.
8. In the middle of the return pass, stop the tractor and confirm that the current position is directly on the AB Line. This ensures there is no cross track error.
9. Park the tractor and exit the cab. Evaluate the tire track pattern between the first and return paths.

10. Measure the difference between the track passes and record the distance. Also note whether the return pass is to the left or the right of the original pass. Record the results.

Note – The offset should be consistently to the left or right.

11. Repeat Step 5 through Step 10 two more times, for a total of three test runs.

Test Run	Offset distance	Offset direction
1		
2		
3		
Total =		
Total / 3 (average offset value) =		

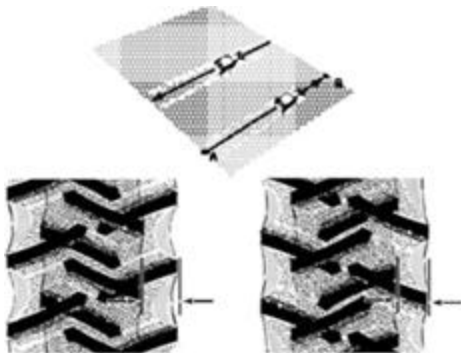

Flag offset method for roll offset

1. Remove any implement from the vehicle. The vehicle draw-bar must be centered.
2. Drive the vehicle to a relatively flat area where you can complete passes that are at least 400 m (1320 ft) in length.
3. Reset the *Roll Offset* value to 0 (zero) on the *Roll Correction* screen. See [Roll / antenna compensation calibration \(page 177\)](#).
4. Create an AB Line.
5. Start a new pass. Engage automatic steering mode when the system is stable. Stop the tractor midway through the pass. Confirm that there is no cross track error: the current vehicle position should be directly on the AB Line.

6. Park the vehicle and exit the cab. Use the hitch pin hole in the drawbar as a guide to insert a flag in the ground to mark the vehicle center-line for this pass.

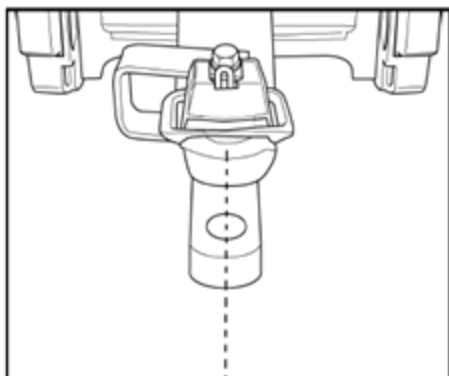

7. Complete the pass. Turn the vehicle around to return along the same pass from the opposite direction.
8. Engage automatic steering mode. Stop the vehicle midway down the pass with the drawbar pin location very close to the marker flag. Confirm that there is no cross track error: the current vehicle position should be directly on the AB Line.
9. Park the vehicle and exit the cab. Use the hitch pin hole in the drawbar as a guide to insert a second flag in the ground to mark the tractor centerline for this pass. Note whether the second pass is to the left or the right of the first pass.
10. Measure the difference between the flags for the two passes and record the distance. Also record whether the return pass is to the left or the right of the original pass. Record the results.

Note – The offset should be consistently to the left or right. The following graphic shows an example of a right offset. Measure the distance between the flags.



11. Repeat Steps 5 to 10 two more times for a total of three test runs. Use the following table to record the offset distance and the left or right direction of offset for each test run.
12. Average the results of the three runs. (Total the offset distances from the three passes and divide by three). Repeat Step 5 through Step 10 two more times, for a total of three test runs.

Test Run	Offset distance	Offset direction
1		
2		

Test Run	Offset distance	Offset direction
3		
Total =		
Total / 3 (average offset value) =		

Line acquisition aggressiveness calibration

1. At the *Vehicle Calibration* screen, select Line Acquisition and tap **OK**.
2. At the *Classic* tab, choose whether you want to use the classic method of line acquisition or the OnSwath method. For more information about OnSwath, see [OnSwath settings \(page 188\)](#).
3. Complete the settings on all other tabs.

The following instructions apply to the OnSwath mode.

Steering Angle tab

The steering angle (or turn radius) is used when acquiring a guidance line. A wider angle creates a sharper turn.

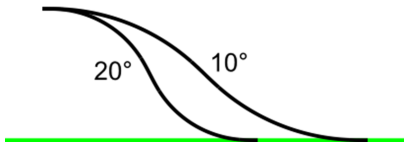
OnSwath Mode Settings	Explanation
Maximum steering angle (nominal)	<p>How sharply the vehicle turns during line acquisition at low speeds. Sets the desired steering angle (turn radius) the system will use during line acquisition. This is not a hard limit and may be exceeded. The value must be set to less than the physical maximum steering angle of the vehicle. A good starting point is 50-75% of the physical maximum. The default values for the vehicle profile are in this range.</p>  <p>Note – Do not set this too high. Too high of a value will cause poor performance.</p> <p>Note – This setting affects the sharpest angle between the vehicle and a towed implement.</p>
Maximum steering angle at	How much the Autopilot will reduce the steering angle used at

OnSwath Mode Settings	Explanation
high speed	<p>higher speeds. The speed noted below the slider indicates when a reduction in steering angle will start to occur.</p> <ul style="list-style-type: none"> • Lower aggressiveness values: Autopilot will limit the sharpness of high speed turns more, to maintain smoother, more stable operation. • Higher aggressiveness values: Autopilot will use the nominal maximum steering angle until the indicated speed is reached.

Slew Rate tab

The slew rate is how quickly the vehicle steers. The maximum slew rate (nominal) is the slew rate the Autopilot system will assume the system is capable of and will plan for during line acquisition.

OnSwath Mode Settings	Explanation
Maximum slew rate (nominal)	<p>Adjust how quickly the steering changes during line acquisition at low speeds.</p> <p>Note – This must be set lower than the physical capacity of the vehicle or instability may occur. Lowering this value may help with vehicle jerk and oscillations.</p> <p>A value that is:</p> <ul style="list-style-type: none"> • Lower: Is better for vehicles with poor hydraulic performance. • Higher: Reduces the slew rate at high speeds less. The speed noted below the slider indicates where the slew rate reduction will begin.
Steering slew rate at high speed	<p>The Autopilot system will reduce the slew rate at speeds above the displayed value.</p> <p>Note – Lowering this value may help with vehicle jerk and oscillations.</p> <p>A value that is:</p> <ul style="list-style-type: none"> • Lower: Reduces the slew rate at high speeds more. This leads to smoother and more stable operation. • Higher: Reduces the slew rate at high speeds less. The speed noted below the slider indicates where the slew rate reduction will begin.

Approach Angle tab

The slew rate is how quickly the vehicle steers. The maximum slew rate (nominal) is the slew rate the Autopilot system will assume the system is capable of and will plan for during line acquisition.

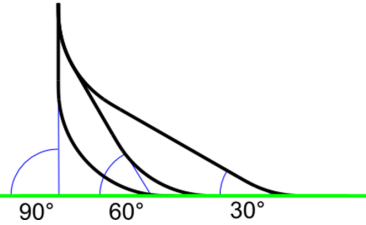
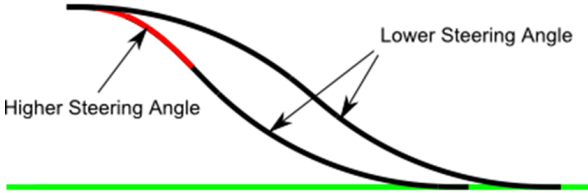
OnSwath Mode Settings	Explanation
<p>Maximum approach angle (nominal)</p>	<p>The desired approach angle that the Autopilot system will drive to the line if adequate space is available. If space is not available, the angle may not be achievable.</p> <p>The following graphic shows possible paths to the line based on different approach angles.</p> 
<p>Initial Turn Aggressiveness</p>	<p>Adjusts how sharp or smooth the initial turn toward to the line will be in comparison to the final turn onto the line. This affects only the initial turn towards, while the final turn onto the line is not affected.</p>  <p>If the value is:</p> <ul style="list-style-type: none"> • Lower: The initial turn will be smoother and more gradual. • Higher: The initial turn will be harder and sharper toward the line.

Tracked tractor calibrations

If you selected a tracked tractor as the make and model, the `TrackSpacing` option displays on the calibration list. (This option is not shown in the *Vehicle Calibration* screen.)

Track Spacing value

At the *Autopilot Track Spacing Calibration* screen, enter the distance between the center of the tracks. The width of the vehicle tracks is the distance from halfway across the width of the left track to halfway across the width of the right track.

Hydraulically-steered tracked tractor

If you selected a hydraulically-steered tracked tractor as the make and model, *Engine Speed* displays on the calibration list.

This group of vehicles includes the CAT/AGCO Challenger Tracked family.

No calibration is required if the system is installed on a CAT MT 700/800 series equipped with the ISO option. This also includes John Deere tracked vehicles.

Autopilot RPM Sensor Calibration screen

The *Autopilot RPM Sensor Calibration* screen enables you to verify that the RPM sensor output is correct.

If the *Engine RPM* value is not close to the actual engine RPM, follow the onscreen instructions to adjust the sensor output.

Autopilot Hydraulic Pump Response Time Calibration screen

The *Autopilot Hydraulic Pump Response Time Calibration* screen verifies and optimizes the response of the hydraulic steering pumps. Follow the onscreen instructions to perform the calibration.

Autopilot Steering Pump Knees Calibration screen

This calibration determines the compensation required for dead-band in the steering pumps.



WARNING – The vehicle needs to move during the Hydraulic Tracked Pump Knees calibration procedure. To avoid injury, be prepared for vehicle movement.

The instructions for this calibration test include several screens. Follow the instructions on each screen.

Tracked vehicle steering wheel calibration

1. Turn off the engine, but keep the ignition key in the run position.
2. At the *Autopilot Calibration* screen, select *Steering Interface Calibration*.
3. **Keep to the suggested time interval** and follow the on screen instructions to turn the steering wheel right and left, full lock.
4. Follow the on-screen instructions until *Calibration Complete* displays on screen.

Row Guidance

Note – The Autopilot system with a supported vehicle is required for Row Guidance. For the list of supported vehicles, please refer to the RG-100 Supported platforms list.

When Row Guidance has been activated on the FM-1000 Plus application, the Autopilot system will follow curved or hillside corn rows that do not exactly match the guidance line.

Row Guidance setup

Before setup, make sure you have activated Row Guidance for use. See [Activate features/plugins for use \(page 60\)](#).

1. At the *Configuration* screen, select  Row Guidance and then tap **Setup**.
2. The *Row Guidance Configuration* screen displays. Complete the settings and tap **OK**.

Note – Verify the measurements are accurate for your vehicle. Measurements can differ due to vehicle variations. Measure distances with the header at the approximate operation height. Inaccurate measurements will result in a degraded performance.

Setting	Explanation
Header	Header model attached to your combine.
Feeler to Axle Offset	Distance from the pivot point of the feeler to the front axle. This measurement must be accurate to within an inch, otherwise the performance will be degraded.
Cutter Bar to Axle Distance	Distance from the front of the cutter bar or point where the crop enters the snapper rollers to the center of the front axle. This measurement must be accurate, otherwise the performance will be degraded.
Feeler Left/Right Offset	Distance of the center of the row crop feelers to the centerline of the vehicle.
Engage Delay	This delay in seconds (0 - 10) will be used when the system is engaged. The system will wait the entered time until inputs are recognized to start row guidance. Use this setting to keep the system from mistaking random stalk strikes on headlands as inputs for steering.
Clear Nudge When Disengaged	Yes: Clears the AutoPilot nudges when the system is disengaged. No: Keep the AutoPilot nudges when the system is

Setting	Explanation
	disengaged.

3. At the *Configuration* screen, tap  Row Guidance and then tap **Diagnostics**.

Item	Explanation
Offline Distance	
Status	Status of the sensor
Enable / Disable	Tap to enable or disable sensors
Voltage	Voltage for the left and right sensor
Voltage status	Status for the left and right sensor

Implement setup for Row Guidance

Before starting the Row Guidance setup, ensure that:

- All cables and components of the system are installed on the vehicle.
- The Autopilot system has been installed and configured with the NavController firmware.
- When setting up Autopilot for use with the RG-100 system, ensure that:
 - A vehicle profile that ends in RG-100 is selected at the *Vehicle Controller Setup* screen
 - The XML header file in the latest release of the vehicle database (.vdb) has been added to the vehicle profiles on the FM-1000 Plus application. Firmware versions after v 6.63 contain an XML file. For instructions on updating the XML file, refer to the support note [Autopilot System: Installing the VDB File \(v6\)](#).
 - Row Guidance has been added (activated) for the FM-1000 Plus application.

1. At the *Home* screen, tap . The *Configuration Selection* screen displays.
2. Tap **Edit** next to Implement. The *Configuration* screen displays.
3. Tap **Add/Remove** to add Row Guidance to the configuration.



Save vehicle profile

Note – From Autopilot firmware version 3.0 and later, the vehicle profile location defaults to “From Database”.

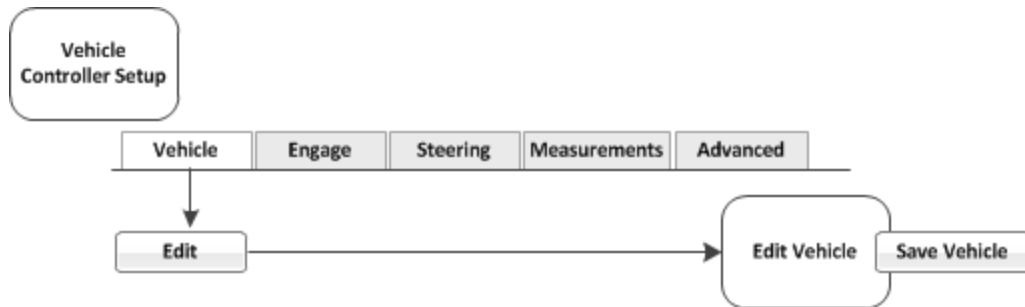
After you configure and calibrate the Autopilot system for your vehicle, you can save that information for later use. This can be useful if you want to adjust the settings or if you move the display from one vehicle to another.



To save a vehicle profile:

1. At the *Home* screen, tap .
2. Select  Autopilot and then tap **Setup**. The *Vehicle Controller Setup* screen displays.
3. On the *Vehicle* tab, tap **Edit**. The *Edit Vehicle* screen displays.
4. Tap **Save Vehicle**.
5. At the *Save Vehicle Configuration* screen, tap in the *Filename* entry box.
6. At the *Enter Save Filename* screen, enter a name for the current vehicle profile and tap **OK**.
7. At the *Edit Vehicle* screen, tap **OK**.

OnSwath settings

With OnSwath, you can customize line acquisition to the vehicle, operation and operator preference. With OnSwath, vehicle behavior during line acquisition is more controlled, more predictable, and more repeatable.

Choose the OnSwath option when calibrating the Line Acquisition Settings for the Autopilot system. See [Line acquisition aggressiveness calibration \(page 181\)](#).

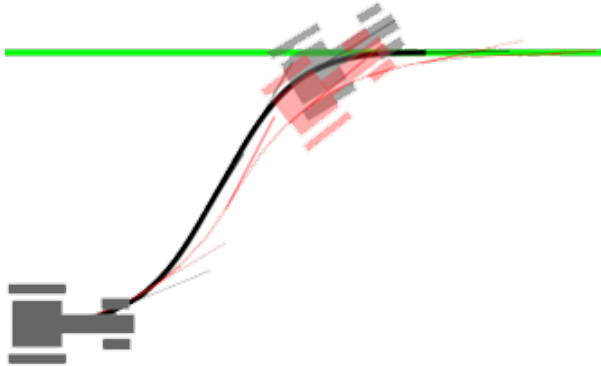

The benefits of OnSwath include:

- Up to 50% faster line acquisition
- Separate tuning for online and line acquisition
- More repeatable performance
- Consistent performance over entire speed range.
- Cab shake eliminated on articulated machines
- Limited turn rates reduce impact on field for tracked machines
- Front axle/nose overshoots more, so that the
- Rear axle on the guidance line faster due to front axle/nose overshooting more

OnSwath requires Autopilot firmware 6 and higher.

NextSwath settings

The optional NextSwath feature/plugin works with Autopilot to enable you to:

- Set up automatic turns to occur between swaths. See [Automatic turn settings \(page 190\)](#) and [Automatic turn \(page 406\)](#).
- Better acquire the guidance line when pulling an implement. See [TrueSwath operation \(page 413\)](#).
- Extend the point for the automatic turn to compensate for larger pulled implements and enable proper coverage. See TrueSwath under [Automatic turn settings \(page 190\)](#).
- Set up automated headlands management to use automated functions you have programmed in your vehicle. See [Automated headlands management settings \(page 194\)](#).
- Set up reminders to occur before you begin or end a swath. See [Automated headlands management settings \(page 194\)](#).

Requirements

NextSwath requires:

- The Autopilot steering system. See [Autopilot system \(page 164\)](#).
- One of the following GNSS correction sources:
 - Omnistar XP
 - Omnistar HP
 - RangePoint RTX
 - Centerpoint RTX (SS, FS, SC)
 - Centerpoint RTK

See [GPS receiver settings \(page 116\)](#).

- OnSwath selected and properly set up for line acquisition. See [OnSwath settings \(page 188\)](#).
- Supported vehicles as defined by the supported platforms list. The vehicle profile in the version 11.00 Vehicle Database (VDB) will enable NextSwath if it is supported. Unsupported VDB files will not allow setup or enabling of NextSwath.
- To use the automated headlands management functions (vehicle integration), a NavController III. See [Automated headlands management settings \(page 194\)](#).

Restrictions

NextSwath cannot be used in with:

- TrueTracker
- Row Guidance RG-100
- FieldLevel II
- WM-Drain

Automatic turn settings

Note – To use NextSwath automatic turn, see [Automatic turn \(page 406\)](#).



The value for end-of-row warning distance is set in the Steering tab. See [Steering settings for Autopilot system \(page 166\)](#).

To set up NextSwath automatic turn capability:

1. Complete the setup for the Autopilot system and the implement. NextSwath uses the following in settings for calculating automatic turns:
 - Swath width. See [Measurements for NextSwath \(page 167\)](#) under Autopilot setup.
 - Application offset. See [Measurements for NextSwath \(page 167\)](#) under Autopilot setup.
 - Hitch to ground contact point. See Geometry tab under [Edit implement settings \(page 158\)](#).





CAUTION – Always verify implement and NextSwath settings, and verify performance for each implement you use for NextSwath. Failure to do so may result in equipment damage.

2. Make sure OnSwath is chosen as the method for the vehicle to acquire the line in the Autopilot setup. See [OnSwath settings \(page 188\)](#) and [Line acquisition aggressiveness calibration \(page 181\)](#).
3. At the *Home* screen, tap . The *Configuration* screen displays.
4. Select  NextSwath and then tap **Setup**.
5. Complete the settings on the following tabs.

Turn Pattern tab

Measurement	Explanation
Type of path	<ul style="list-style-type: none"> • Shortest (sharper turn) (default): The path of the turn will be sharper and as short as possible. To determine this path, the system uses: <ul style="list-style-type: none"> • Swath width • Steering angle and slew rate settings for OnSwath • Turn speed • The Turn Pattern option you have chosen • Smoothest (rounder turn): The path of the turn will be smoother and gentler (with a constant curve), and likely longer. Use this setting for large applications such as wide spraying. If you change to a swath which causes the vehicle to skip a larger number of swaths for a turn, the radius for this turn will increase.
Turn Pattern	<p>When the limitations of the steering system and the width of the swath do not allow a turn to be completed within the distance between swaths, the turn must extend beyond the swath lines. Choose which pattern to use in such a case.</p> <ul style="list-style-type: none"> • Keyhole: An equal amount of turning outside the swath region occurs on each side of the turn. • Turn wide at start: The turn extends widely beyond the existing line to be able to line up accurately to the next swath. The turning occurs outside of the swath at the beginning of the turn. • Turn wide at end: The turn begins on the existing line and extends widely beyond the next swath. The turning occurs outside of the next swath at the end of the turn.
Swath Change Limit	Enter the maximum number of swaths the operator can move to, up to 10 swaths (up to 500 feet/152.4 meters).

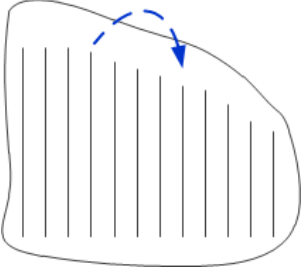
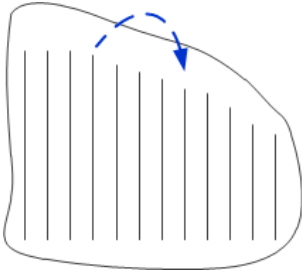
Turn Point tab

Measurement	Explanation
<p>Shorten or Extend Swath</p>	<ul style="list-style-type: none"> Maximize infill coverage (extend): The turn starts at the boundary between the headland and infill. All of the turn occurs outside of the infill. <p>Note – When your boundaries are not regular, the turn point may be out of the boundary.</p>  <ul style="list-style-type: none"> Minimize headland usage (shorten): The turn may start inside the infill to attempt to keep the turn inside the headland region.
<p>Turn Point Inside/Outside boundary</p>	<p>If you have a boundary without headlands, set the location of the turning point in relation to the boundary, such as 10 feet (3.05 meters) outside the boundary or 10 feet (3.05 meters) inside the boundary. This setting only applies to Productive Area Feature Field Boundaries, and does not apply to headland infill boundaries.</p> <p>Note – When your boundaries are not regular, the turn point may be out of the boundary.</p>  <hr/> <p> WARNING – Interaction with and avoidance of boundaries is solely the operator's responsibility. While NextSwath can use field boundaries for a reference point for turn start points, the trained and qualified operator is responsible for determining offsets from field boundaries. NextSwath does not calculate distance of the vehicle or machinery from the boundary during the turn.</p> <hr/>

Measurement	Explanation
TrueSwath Swath Extension	<p>When TrueSwath is enabled on the <i>Run</i> screen, the system will extend the original turn point. The additional distance delays the vehicle turn and enables the implement to fully cover the swath.</p> <p>Tap Calculate to obtain this value. The system uses several values to complete this calculation, including the distance of:</p> <ul style="list-style-type: none"> • The rear axle of the vehicle to the hitch of the implement • The hitch-to-ground contact <p>Change this value when you change to a different implement. See TrueSwath operation (page 413).</p>

Parameters tab

Measurement	Explanation
Turn Speed	<p>All automated turns are optimized for this speed. If the vehicle is traveling faster than this speed, the Autopilot system will not start the turn. If the vehicle speed is increased during the turn and exceeds this speed, the system will post a warning to the operator. If speed does not reduce within two seconds, the turn will be disengaged. It is recommended that this value be set to the highest speed for which turns will be made.</p> <p>Note – Settings for OnSwath that have an affect on the path of the planned turn are: Maximum nominal steering angle, maximum nominal steering slew rate and aggressiveness. See Line acquisition aggressiveness calibration (page 181).</p>
Minimum Turn Radius	<p>The smallest radius for the automatic turn. To calculate the value, drive the vehicle/implement combination in the tightest turn desired. Then measure the radius of this turn.</p> <p>Note – This setting applies for turns with or without TrueSwath. It does not apply to line acquisition. Settings for OnSwath and turn speed may cause the system to use a larger turn radius for regular and TrueSwath automated turns.</p>
Remote Engage Confirms Auto Turn	<p>Choose Yes if you want the option to use the Remote Engage button as well as the touchscreen to confirm an automatic turn.</p>

Automated headlands management settings

Note – For operation, see [Using automated headlands management \(page 415\)](#).

The automated headlands management capability of NextSwath enables you to:



- Have your vehicle and implement perform certain operations automatically after you have programmed these functions into your vehicle. For example, you may want the implement automatically raise at the end of a swath and automatically lower at the beginning of the swath.
- Set up reminders to prompt you to perform an action at the appropriate time whether you have a programmable vehicle or not

To set up NextSwath automated headlands management:

1. Complete the setup for the Autopilot system and the implement. NextSwath uses the following in implement setup for calculating automatic turns:
 - Swath width. See [Measurements for NextSwath \(page 167\)](#) under Autopilot setup.
 - Implement offset. See [Measurements for NextSwath \(page 167\)](#) under Autopilot setup.
 - Hitch to ground contact point. See Geometry tab under [Edit implement settings \(page 158\)](#).



CAUTION – Always verify implement and NextSwath settings, and verify performance for each implement you use for NextSwath. Failure to do so may result in equipment damage.

2. Make sure OnSwath is chosen as the method for the vehicle to acquire the line in the Autopilot setup. See [Line acquisition aggressiveness calibration \(page 181\)](#).
3. At the *Home* screen, tap . The *Configuration* screen displays.
4. Select  NextSwath and then tap **Setup**.
5. Complete the settings on the tabs:
 - Turn Pattern
 - Turn Point
 - Parameters
 See [Automatic turn settings \(page 190\)](#).
6. Complete the settings on the following tabs and screens.

Swath Start Events tab

Tap a row to add an event that will occur before or during the swath start. The system displays the *Edit Start of Swath Event* screen.

Column Heading	Explanation
Event	The name of the event.
Distance or Time	The event will occur in reference to a certain distance or a certain time to the turn point.
Occurs Before/After	Whether the event will occur before or after the start/end of the swath.
Sound alert	Whether an alert will sound to alert you of the event.
Text alert	Whether a message will display to alert you of the event.

Edit Start of Swath Event screen

The event you create here will be one that occurs at the start of the swath.

Item	Explanation
Event	<p>Choose the event you want from the list:</p> <ul style="list-style-type: none"> • Start application: A reminder to start the application • Stop application: A reminder to stop the application • Lower implement: A reminder to lower the implement • Raise implement: A reminder to raise the implement • Adjust speed for turn: A reminder to adjust your speed for the turn • Adjust speed to operating speed: A reminder to adjust your speed to the operating speed • Perform Sequence A: A reminder or command to start the automated operations previously recorded on your vehicle. • Perform Sequence B: A reminder or command to start the automated operations previously recorded on your vehicle.
Distance or time	Choose whether you want to use distance or time to define when the event occurs.
Occurs before/after	Choose whether the event will occur before or after the start of the event.
Sound alert	Choose Yes if you want the system to alert you with a sound when the event is about to occur.
Text alert	Choose Yes if you want the system to display a message reminding you of the start of the event.

Swath End Events tab

Tap a row to add an event that will occur before or during the swath end. The system displays the *Edit End of Swath Event* screen.

Column Heading	Explanation
Event	The name of the event.
Distance or Time	The event will occur in reference to a certain distance or a certain time to the turn point
Occurs Before/After	Whether the event will occur before or after the start/end of the swath.
Sound alert	Whether an alert will sound to alert you of the event.
Text alert	Whether a message will display to alert you of the event.

Edit End of Swath Event screen

The event you create here will be one that occurs at the end of the swath.

Item	Explanation
Event	<p>Choose the event you want from the list:</p> <ul style="list-style-type: none"> • Start application: A reminder to start the application • Stop application: A reminder to stop the application • Lower implement: A reminder to lower the implement • Raise implement: A reminder to raise the implement • Adjust speed for turn: A reminder to adjust your speed for the turn • Adjust speed to operating speed: A reminder to adjust your speed to the operating speed • Perform Sequence A: A reminder or command to start the automated operations previously recorded on your vehicle. • Perform Sequence B: A reminder or command to start the automated operations previously recorded on your vehicle.
Distance or time	Choose whether you want to use distance or time to define when the event occurs.
Occurs before/after	Choose whether the event will occur before or after the start of the event.

Item	Explanation
Sound alert	Choose Yes if you want the system to alert you with a sound when the event is about to occur.
Text alert	Choose Yes if you want the system to display a message reminding you of the start of the event.

Vehicle Integration tab



WARNING – Do not use automated implement functions to: 1) control hazardous materials (including NH3) or 2) operate implements near ground laborers. Failure to follow these restrictions could result in serious injury or death.

The settings on this tab only apply if your vehicle has been programmed for automated headlands management (vehicle/implement performing functions automatically in a specific sequence). The signal issued from the third solenoid of the NavController III starts the automatic operations you have created and saved on the vehicle. Any timing for each event in the sequence must be set up from the vehicle interface. Refer to the appropriate tractor operator manual.

Note – Automated functions do not work with on vehicles that use the third solenoid output for the “On when engaged” function.

Requirements

To set up and use the automated functionality, you must have:

- The automated headlands management (Vehicle Integration) feature/plugin that is unlocked and activated
- A vehicle that is supported by a platform kit which offers automated functions
- A NavController III (to output the signal for operation from the third solenoid)

Note – There is only one solenoid output on the NavController III, meaning only one button can be triggered.

Column Heading	Explanation
Sequence A Trigger	Choose which operation will trigger the sequence: <ul style="list-style-type: none"> • Manual: Operator taps a button on the tractor to begin the automated functions • Third solenoid: Signal is sent from the NavController to begin the automated operations
Sequence B Trigger	Choose which operation will trigger the sequence:

Column Heading	Explanation
	<ul style="list-style-type: none"><li data-bbox="603 342 1348 409">• Manual: Operator taps a button on the tractor to begin the automated functions<li data-bbox="603 427 1362 495">• Third solenoid: Signal is sent from the NavController to begin the automated operations

EZ-Pilot assisted steering system

The EZ-Pilot assisted steering system uses GPS to provide automatic vehicle guidance.

For cabling information, see XCN-2050 Cabling Guide.

For operational information, see [EZ-Pilot system operation \(page 416\)](#).

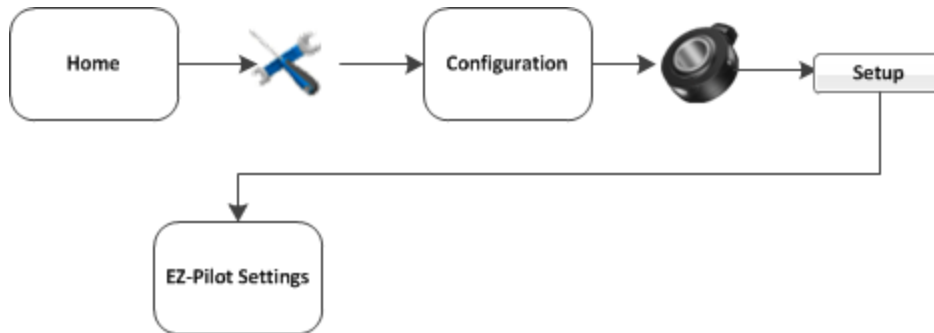

To set up the EZ-Pilot system:

1. Complete the [GPS receiver settings \(page 116\)](#).
2. Complete the EZ-Pilot settings.
3. Calibrate the EZ-Pilot system.

Vehicle settings for EZ-Pilot system

1. At the *Configuration* screen, select  EZ-Pilot and tap **Setup**. The *EZ-Pilot Settings* screen displays.
2. On the *Vehicle* tab complete the settings as appropriate.

Setting	Explanation
Vehicle Type	Type of vehicle
Axle to Antenna Offset	<p>The horizontal distance between the axle and the antenna. Measure the distance accurately (within 3 inches). An incorrect offset may cause poor steering performance.</p> <p>Take the measurement from the antenna to the correct point of your vehicle:</p> <ul style="list-style-type: none"> • From the rear axle for MFWD, Sprayer, Floater, Truck • From the front axle for 4WD tractor, Combine, Swathers (For swathers, it is recommended that you place the antenna directly

Setting	Explanation
	<p>over or ahead of the front axle.)</p> <ul style="list-style-type: none"> From the tracked center for tracked vehicles <p>If the antenna is:</p> <ul style="list-style-type: none"> In front of the axle, enter a forward distance. Behind the axle, enter a back distance.
Antenna Height	The distance between the ground and the top of the GPS antenna.
Wheelbase	The horizontal distance between the center of the front wheel and the center of the back wheel.

Steering settings for EZ-Pilot system

On the *EZ-Pilot Settings* screen at the *Steering* tab, complete the settings for steering.

Setting	Explanation
Nudge Increment	The distance the Nudge button on the <i>Run</i> screen moves when you tap it.
Angle Per Turn	<p>The angle the wheels turn during one full rotation of the steering wheel. If the setting is too:</p> <ul style="list-style-type: none"> Low: The system will turn the wheel too much and the vehicle will perform S-turns. High: The system will turn the wheel too little and the vehicle will not hold the line.
Freeplay Left	Adjust if the vehicle drives consistently to the right of the line.
Freeplay Right	Adjust if the vehicle drives consistently to the left of the line.
Motor Speed	The maximum rate at which the SAM-200 will operate.
Online Aggressiveness	<p>How aggressively the EZ-Pilot system corrects the deviations from the current guidance line. A setting that is:</p> <ul style="list-style-type: none"> Very high: Will correct deviations quickly, but the vehicle may steer erratically. Very low: Will allow a smoother drive down the swath, but the vehicle may go further offline before the deviation is corrected.
Approach Aggressiveness	How quickly the EZ-Pilot system steers the vehicle onto the

Setting	Explanation
	<p>current guidance line. A setting that is:</p> <ul style="list-style-type: none"> • Very high: Steers the vehicle quickly, but the steering correction may be too severe. • Very low: Steers the vehicle very slowly, but the vehicle may overshoot and travel too far down the swath before reaching the guidance line.

Engage settings for EZ-Pilot system

At the *EZ-Pilot Settings* screen on the *Engage* tab, you can edit the system's engage and disengage behavior if you need to change the settings.

Setting	Explanation
Operator Time Out	If the steering system is engaged and there has been no operator interaction with the FM-1000 Plus application for longer than the operator timeout period, a message displays on the screen. If you acknowledge the message within 30 seconds, the system does not disengage. Otherwise, the EZ-Pilot system steering disengages.
Minimum speed	Minimum speed at which the system can engage. If the system is engaged and the speed drops below this limit, the system disengages.
Maximum speed	Maximum speed at which the system can engage. If the system is engaged and the speed increases above this limit, the system disengages.
Maximum angle	Maximum angle at which the system can engage. If the vehicle approaches the swath at an angle greater than this limit, it cannot be engaged.
Engage offline	Maximum distance from the swath at which the system can engage. If the vehicle approaches the swath at a distance greater than this limit, it cannot be engaged.
Disengage offline	Maximum distance from the swath at which the system can remain engaged. If the vehicle drives offline greater than this limit, the system disengages.
Coverage log	Displays on the <i>Run</i> screen to show what areas have been applied.

Setting	Explanation
	<ul style="list-style-type: none"> • Select When Engaged to automatically show coverage logging when the system is engaged. See Engage button (page 359). • Select Manual to show coverage logging only when you tap .
Override sensitivity	Amount the steering wheel must be turned manually before the system disengages.

EZ-Pilot system calibration

To calibrate the EZ-Pilot system to work with the FM-1000 Plus application, you must complete the following:

1. Enter the vehicle settings.
2. Complete calibration for T3™ roll compensation. See [T3 roll compensation calibration \(page 204\)](#).
3. Calibrate the EZ-Pilot system:
 - Angle per turn. See [SAM-200 calibration \(page 202\)](#).
 - Aggressiveness and Freeplay offset. See [Steering performance calibration \(page 203\)](#).
4. Confirm the calibration settings.



Note – You may have to perform the EZ-Pilot calibration more than once to achieve optimal results.

SAM-200 calibration

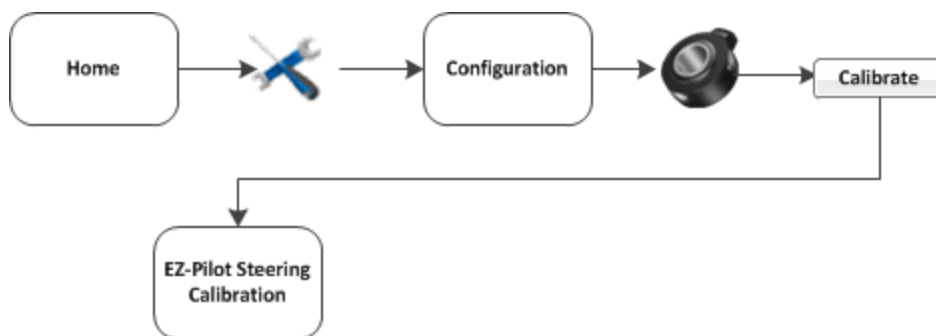
Note – You must calibrate the IMD-600 before you calibrate the SAM-200.



1. At the *Configuration* screen, select  EZ-Pilot and then tap **Calibrate**. The *EZ-Pilot Steering Calibration* screen displays.

2. Select SAM-200 and tap **OK**.
3. Ensure that you are operating the vehicle in an open field with ample area for the vehicle to make right and left turns.
4. For best results, operate the vehicle at between 2 and 4 mph.
5. To calibrate the right turn angle:
 - a. Drive straight forward until  (yellow) displays.
 - b. Tap . Allow the system to operate for 20 seconds until you receive a message that the calibration is complete.



WARNING – Auto guidance systems cannot avoid items in the field such as obstacles. Make sure you are adequately trained to operate the auto guidance system.

6. Repeat the steps to calibrate the left turn angle.

Steering performance calibration

To calibrate the EZ-Pilot system and set the correct steering performance parameters, the following steps must be completed with the vehicle moving forward along an A-B line.

1. At the *EZ-Pilot Steering Calibration* screen, select *Steering Performance*. The *EZ-Pilot Steering Performance* screen displays.
2. Tap the *Override Sensitivity* tab.
3. Adjust the force required to manually override EZ-Pilot.
4. Tap the *Aggressiveness* tab. The aggressiveness setting controls the amount of force that required to disengage the system and how aggressively the system holds the line. If the setting is:
 - Too low, the vehicle will not hold the line
 - Too high, the vehicle may over-correct and make S-turns
5. Adjust the *Aggressiveness* setting to get the vehicle as close to the line as possible without going into S-turns. To make turns:
 - More aggressive: Increase the aggressiveness value.
 - Less aggressive: Decrease the aggressiveness value.
6. Tap the *Free Play* tab.
7. Adjust the freeplay offset if the steering has greater freeplay in one direction than the other, causing it to drive consistently to one side of the guidance line. To make this adjustment:
 - a. Engage the on an AB line.
 - b. If the vehicle is offline to the left, increase the freeplay offset to the right.

- c. If the vehicle is offline to the right, increase the freeplay offset to the left.
- d. Enter the parameters and then tap **OK**. The *EZ-Pilot Steering Calibration* screen displays.

Note – If you are calibrating a 4WD articulated vehicle, you may need to set the *Motor Speed* setting to *Auto Low*.

Note – The *Advanced Calibration* tab is currently not available. To access these options, select *EZ-Pilot Diagnostics* from the main *Configuration* screen.

8. Tap **OK**. The *Configuration* screen displays.

T3 roll compensation calibration

The EZ-Pilot system contains sensors that use T3 terrain compensation technology to provide roll compensation when the vehicle is on a slope or drives over a bump. For roll compensation to work correctly, the IMD-600 must be calibrated.

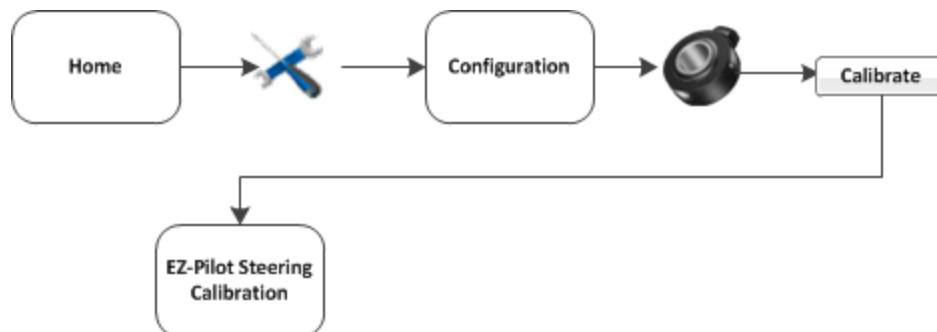

1. At the *Configuration* screen, select  EZ-Pilot and then tap **Calibrate**. The *EZ-Pilot Steering Calibration* screen displays.
2. Select *IMD-600 Orientation* and tap **OK**. The *EZ-Pilot Roll Calibration* screen displays.

Note – For best accuracy, install the *IMD-600* as shown in the installation instructions for the supported platform in which it is being installed. Make sure the *IMD-600* is installed at right angles to the center line of the vehicle. Non-orthogonal angles will cause performance degradation.

3. From the *Orientation* list, select the orientation of the *IMD-600* module and then tap **Next**.
4. Park the vehicle, mark the inside position of both sets of wheels and then tap **Next**.
The *FM-1000 Plus* application records the roll offset in the first direction. This takes approximately 20 seconds. Do not move the vehicle while the offset is being read.
5. Turn the vehicle around, ensure the wheels are parked over the marks created in step 4 and then tap **Next**.

The *FM-1000 Plus* application records the roll offset in the second direction. This takes approximately 20 seconds. Do not move the vehicle while the offset is being read.

The T3 calibration results display in the *Roll Offset* section of the screen. The roll offset value should be between 0° and 4°.

6. Tap **OK**. The *EZ-Pilot Steering Calibration* screen displays.

EZ-Steer assisted steering system

The EZ-Steer assisted steering system uses GPS to provide automatic vehicle guidance.

For cabling information, see XCN-2050 Cabling Guide.

For operational information, see [EZ-Steer system operation \(page 419\)](#).

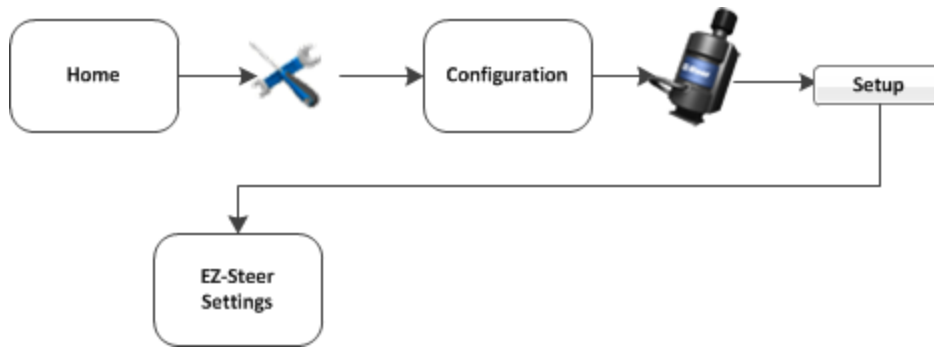

To set up the EZ-Steer system:

1. Complete the [GPS receiver settings \(page 116\)](#).
2. At the *Configuration* screen, select  EZ-Steer and tap **Setup**. The *EZ-Steer Settings* screen displays.
3. Complete the settings as appropriate.

Setting	Explanation
Vehicle Type	Type of vehicle
Axle to Antenna Offset	<p>The horizontal distance between the axle and the antenna. Measure the distance accurately (within 3 inches). An incorrect offset may cause poor steering performance.</p> <p>Note – Measure the offset distance as accurately as possible (within 3"). An incorrect offset may cause poor steering performance.</p> <ul style="list-style-type: none"> • If the antenna is in front of the axle, enter a forward distance. • If the antenna is behind the axle, enter a back distance.
Antenna Height	Measure the antenna height vertically, from the ground to the base of the antenna.
Wheelbase	The horizontal distance between the center of the front wheel and the center of the back wheel.

Note – The *Engage, Steering, and Advanced* tabs on this screen are completed automatically with starting values, based on the vehicle type selected.

4. Tap **OK**. The *Configuration* screen displays.

Engage settings for EZ-Steer

To edit the EZ-Steer system engage settings:

1. At the *EZ-Steer Settings* screen, select the *Engage Options* tab and complete the settings.

Setting	Explanation
Minimum speed	Minimum speed at which the system can engage. If the system is engaged and the speed drops below this limit, the system engages.
Maximum speed	Maximum speed at which the system can engage. If the system is engaged and the speed increases above this limit, the system disengages.
Maximum angle	Maximum angle at which the system can engage. If the vehicle approaches the swath at an angle greater than this limit, it cannot be engaged.
Engage offline	Maximum distance from the swath at which the system can engage. If the vehicle approaches the swath at a distance greater than this limit, it cannot be engaged.
Disengage offline	Maximum distance from the swath at which the system can remain engaged. If the vehicle drives offline greater than this limit, the system disengages.
Engage on A-B	Set up whether the system can or cannot be engaged on the master A-B line.
Override sensitivity	Amount the steering wheel must be turned manually before the system disengages.
EZ-Steer external switch	Set up the behavior of a seat or foot switch.

2. Tap **OK**. The *Configuration* screen displays.

Advanced settings for EZ-Pilot

At the *EZ-Pilot Settings* screen on the *Advanced* tab, complete the settings as appropriate.

Setting	Explanation
Roll Offset Angle	<p>Fine-tunes the roll calibration value after it has been determined in the initial calibration process.</p> <p>Note – This value is in roll degrees, not distance (inches, cm, and so on) offline.</p>
Estimate Steering Angle Bias	<p>For long, straight passes, helps drive the lingering cross track error due to erroneous steering angle measurements to zero.</p>
Dynamic Approach Angle (Heading)	<p>When enabled:</p> <ul style="list-style-type: none"> • Allows for a steeper approach path to the AB line when further away • Reduces the path angle as the vehicle approaches the line <p>Note – This setting does not increase the angle at which the system can be engaged from the line, but does increase the approach angle after engagement.</p>
Steering Slew Limit	<p>Controls the maximum sustained rate that the steering will respond.</p> <ul style="list-style-type: none"> • Lower value: Steering is smoother and slower. <p>Note – A value that is too low may cause vehicle instability.</p> <ul style="list-style-type: none"> • Higher value: Steering is quicker and more responsive.
Steering Acceleration Limit	<p>Controls the rate at which the EZ-Pilot system switches from no steering movement to the full steering slew rate.</p> <ul style="list-style-type: none"> • Lower value: Steering is smoother. <p>Note – A value that is too low may cause vehicle instability. Set the value to zero to disable the setting.</p> <ul style="list-style-type: none"> • Higher value: Steering is more aggressive.

EZ-Steer system calibration

Before you calibrate the vehicle:

- Ensure that the vehicle's hydraulic oil is up to operating temperature. Refer to the vehicle documentation.
- Ensure that the tire pressure is correct.
- Perform initial calibration without an implement or with the booms folded in on a high-clearance sprayer. After initial calibration is completed, you can fine tune the settings with the implement or booms folded out.
- Choose a field with the smoothest possible surface and perform calibration at the normal operating speed for the vehicle.
- Have a straight AB line available. If you do not create an A–B line before you begin the calibration, the system will prompt you to open a field and create one.

To calibrate the EZ-Steer system:

1. Complete the [T2 roll compensation calibration for EZ-Steer system \(page 210\)](#).
2. Calibrate the EZ-Steer system.
 - [Angle per Turn calibration for EZ-Steer system \(page 209\)](#)
 - [Aggressiveness calibration for EZ-Steer system \(page 208\)](#)
 - [Freeplay Offset calibration for EZ-Steer system \(page 209\)](#)
3. Confirm the calibration settings.

Note – You may have to perform the EZ-Steer calibration more than once to achieve optimal results.

Aggressiveness calibration for EZ-Steer system

The aggressiveness setting fine-tunes how aggressively the system holds the line. If the setting is too low, the vehicle will not hold the line. If the setting is too high, the vehicle may over-correct and make S-turns.

To configure the aggressiveness settings, at the *EZ-Steer Steering Performance* screen select the **Step 2** tab.

Adjust the aggressiveness setting to get the vehicle as close to the line as possible without going into S-turns. To make:

- More aggressive turns, increase the aggressiveness
- Less aggressive turns, decrease the aggressiveness

Angle per Turn calibration for EZ-Steer system

Angle per Turn is a course adjustment of the angle that the wheels turn through during one full rotation of the steering wheel. If the setting is too low, the system may require several attempts to reach the line.

To calibrate the EZ-Steer system, and set the correct steering performance parameters, complete the following steps with the vehicle moving forward along the A-B line.

Note – Use the Cross Track Error history plot on the top right of the page and the Average Offline distance to optimize EZ-Steer performance for each step in the calibration.

1. At the *EZ-Steer Steering Calibration* screen, select *Steering Performance*. The *EZ-Steer Steering Performance* screen displays.
2. Select the Step 1 tab.
3. With the vehicle moving forward along the A–B line:
 - a. Nudge the vehicle left or right 1 m (3') from the A–B line.
 - b. Engage the EZ-Steer system.
4. Adjust the Angle per Turn value so that when the system is engaged, the vehicle moves close to the guidance line. To make:
 - More aggressive turns, decrease the value for angle per turn
 - Less aggressive turns, increase the value for angle per turn

Freeplay Offset calibration for EZ-Steer system

Add a Freeplay Offset if the steering has greater freeplay in one direction than the other, causing it to drive consistently to one side of the guidance line.

Note – If you are calibrating a 4WD articulated vehicle, you may need to set the *Motor Speed* setting to *Auto Low*.

Note – The *Advanced Calibration* tab is currently not available. To access these options, select the *EZ-Steer Diagnostics* from the main *Configuration* screen.

1. To adjust the Freeplay Offset settings, at the *EZ-Steer Steering Performance* screen select the Step 3 tab.
2. Engage the system on the A–B line. If the vehicle is offline:
 - To the left, increase the freeplay offset to the right
 - To the right, increase the freeplay offset to the left



WARNING – Many large and sudden changes in satellite geometry caused by blocked satellites can cause significant position shifts. If operating under these conditions, auto-guidance systems can react abruptly. To avoid possible personal injury or damage to property under these conditions, disable the auto-guidance system and take manual control of the vehicle until conditions have cleared.

3. Enter the parameters and then tap **OK**. The *EZ-Steer Steering Calibration* screen displays.
4. Tap **OK**. The *Configuration* screen displays.

T2 roll compensation calibration for EZ-Steer system

The EZ-Steer system contains sensors that use T2™ terrain compensation technology to provide roll compensation when the vehicle is on a slope or drives over a bump. For roll compensation to work correctly, the controller must be calibrated.

1. Select  EZ-Steer and then tap **Calibrate**. The *EZ-Steer Steering Calibration* screen displays.
2. Select Controller Orientation and tap **OK**. The next step in calibration displays.
3. From the Orientation list, select the orientation of the steering control module and then tap **Next**. The next step in calibration displays.
4. Park the vehicle, mark the inside position of both sets of wheels and then tap **Next**. The FM-1000 Plus application records the roll offset in the first direction. This takes approximately 20 seconds. Do not move the vehicle while the offset is being read.
5. Turn the vehicle around, ensure the wheels are parked over the marks created in the previous step and then tap **Next**. The next step in calibration displays.

The FM-1000 Plus application records the roll offset in the second direction. This takes approximately 20 seconds. Do not move the vehicle while the offset is being read.

The T2 calibration results will be listed in the Roll Offset section. The Roll Offset value should be between 0° and 4°.
6. Tap **OK**. The *EZ-Steer Steering Calibration* screen displays.

Field-IQ system setup

In this chapter:

Field-IQ system functionality	212
Pressure limiting	214
General setup information	215
Implement setup for Field-IQ	215
Field-IQ system setup	218
Material setup	219
Control setup	222
Rate Control tab	230
Rate control module setup	232
Equipment calibration for Field-IQ	239

When the Field-IQ system is installed, the FM-1000 Plus application can control:

- Planters
- Sprayers
- Air seeders
- Liquid strip-till tool-bars
- Spinner spreaders

Field-IQ system functionality

The Field-IQ system can perform automatic section control using:

- Tru Count Air Clutch®
- Boom valves
- LiquiBlock™
- Various section control devices

While performing automatic section control it can control rates using a prescription with:

- Rawson™ drives
- Servo valves
- PWM valves
- Various flow control devices

The Field-IQ system can be configured to perform different functions.

Application	Main functions
Planter	<ul style="list-style-type: none"> • Seed Section Control of up to 48 individual rows (Field-IQ system section control module(s) needed) using Tru Count Air Clutches • Seed Rate Control using up to 4 Rawson drives to change seed population • Seed Rate control using up to 6 PWM drives to change seed population • Liquid Fertilizer Control of up to 48 individual liquid nozzles (Field-IQ section control module(s) needed) using Tru Count LiquiBlock valves • Variety tracking
Sprayer	<ul style="list-style-type: none"> • Liquid Rate Control, using either a PWM or Servo control valve • Liquid Section Control of up to 48 individual spray nozzles (Field-IQ Section Control Module(s) needed) using existing boom shutoff valves or Tru Count LiquiBlock valves • Pressure limiting (page 214)
Strip-till (liquid)	<ul style="list-style-type: none"> • Liquid Section Control of up to 48 sections or individual sections (Field-IQ Section Control Module(s) needed) using Tru Count LiquiBlock valves • Liquid Rate Control using up to 2 Rawson drives connected to fixed displacement pumps, such as CDS-John Blue piston pumps, to change liquid rate (Field-IQ Rawson Control Module(s) needed)

Application	Main functions
	<ul style="list-style-type: none"> • Liquid Rate Control using either a PWM or Servo control valve and flow meter
Spreading	<ul style="list-style-type: none"> • Spreading Rate Control using a Rawson Drive (Field-IQ Rawson Control Module(s) needed) • Spreading Rate Control using either a PWM or Servo control valve and application rate sensor
Air seeder	<ul style="list-style-type: none"> • Section Control of up to 96 rows of blockage sensors • Section Control of multiple materials simultaneously with manual rate or prescription • Control existing PWM, linear actuators, or servo systems • Auxiliary sensors can read fan speed, bin level, air pressure, and implement switches

For installation and cabling information, see XCN-2050 Cabling Guide.

Pressure limiting

To control the application rate on a sprayer, two factors must be adjusted in relation to forward speed to keep the application constant:

- [Control flow in relation to speed](#)
- [Pressure limiting](#)

Pressure limiting supports these valve/drive types:

- PWM
- Bypass Servo
- Pump Servo

Flow control

Application rate control on a sprayer is maintained by controlling the flow of material directed to the boom. The volume of material sent to the boom is determined by the:

- Number of sections that are open
- Forward speed
- Target rate

The pressure will vary within the sprayer depending on such factors.

When speed drastically changes, such as when the vehicle slows before a turn or to avoid an obstacle, pressure can drop or rise above the recommended pressure for the tip and create an incorrect spray pattern.

Pressure limiting

While the pressure will vary within the boom depending on its operation, good canopy penetration depends on maintaining a consistent spray pattern. Nozzle pressure must be within a working range for a consistent pattern.

Pressure limiting is used to limit the pressure during operation between a minimum and maximum pressure. The system operates with flow control (the flow meter) until it reaches either the maximum or minimum pressure limit. After reaching the limit, the system holds at the specific limit. The pressure will adjust to the high or low limit until commanded to return to normal flow control.

By limiting the pressure, the psi or kpa stays within an acceptable range when the sprayer speed decreases or increases. Pressure limiting ensures a sufficient but not excessive flow through the nozzle to maintain a good spray pattern.

Pressure limiting works only when sections are on. When sections are off, the system will use standby pressure if you are using a bypass or PWM valve.

Low pressure example

During normal operation, all sections are closed but one and the system is running a low rate. To keep the nozzles from pulsing or fluctuating, the system will switch to the low pressure limit.

High pressure examples

In the field during a high flow if you shut the sections off, there will be a spike in pressure. Pressure limiting protects the system from these spikes.

If the vehicle speed is too fast or the rate is too high for the tip size, pressure limiting prevents over pressurization of the system.

Setup

The pressure limiting settings begin at the [Rate Control tab \(page 230\)](#).

General setup information

Before starting the Field-IQ system setup, ensure that:

- All components of the system are installed on the vehicle and implement.
- Field-IQ has been activated for use. See [Activate features/plugins for use \(page 60\)](#).
- The implement has been set up and configured for the appropriate operation, such as planting or spraying. See [Implement setup for Field-IQ \(page 215\)](#).

For cabling information, see the *XCN-2050 Cabling Guide*.

For operational information, see [Field-IQ operation \(page 389\)](#).

Implement setup for Field-IQ

The implement type defines the set up options for the Field-IQ system.

For example, if the material is set to granular fertilizer and the implement is set to sprayer, the system will not allow you to enter a gate height setting.

When running a fertilizer cart, set the implement type to air seeder. This will allow the user to not have to enter gate dimensions.

1. Navigate to the *Implement Setup* screen.
2. On the Implement Type tab:
 - a. From the Operations list, choose the operation.
 - b. Tap **Edit**. The *Select Implement Layout* screen displays.

- c. Tap the appropriate layout and then tap **OK**.

Operations	Layouts
Spreading	Pull-type spreader Self-propelled spreader
Spraying	Self-propelled, front boom Self-propelled, rear boom Pull-type sprayer
Planting	Standard Front split Rear split Center offset
Seeder	None
Tillage	None
Other	None

3. On the **Measurements** tab, enter the measurements for the implement.

These measurements are crucial to the performance of the vehicle and implement in the field.

Measurement	Explanation
Swath Width	The distance between guidance lines. This is typically the working width of your implement, vehicle, or header.
Application Width	The width of a pass including any overlap. This measurement is reflected by the FM-1000 Plus application's coverage map.
Application Offset	<p>The distance between the tractor and the implement:</p> <ul style="list-style-type: none"> • Guidance Only: This is measured from the fixed axle of the vehicle to the location where the coverage will be mapped. Used to reference from the vehicle to the implement / application point. • Field-IQ: Measured from the fixed axle of the vehicle to the implement tool bar. <p>The offset is measured from the fixed axle of the vehicle to the point on the implement where coverage logging will be mapped.</p> <p>The fixed axle varies depending on vehicle type:</p> <ul style="list-style-type: none"> • Rear axle on front-steering tractors and self-propelled sprayers • Front axle on 4 x 4 articulated tractors

Measurement	Explanation
	<ul style="list-style-type: none"> Center of tracks on tracked tractor <p>Note – If you set Application Offset to zero, you will not be able to select Drawbar for the Type in the Geometry tab.</p>
Rows	Number of rows that are covered by the implement.
Left/Right Offset	This measurement adjusts the tractor path so that an offset implement is centered on the guidance line. It is measured from the center of the vehicle to the center of the implement or header.

4. On the Geometry tab:

- a. Select the type, which controls how the implement is modeled: Either Hitch / 3 pt or Drawbar.

Note – If Application Offset is set to zero in the Implement Type tab, you cannot select Drawbar.

- b. Enter the appropriate measurement. Some measurements are only available if Implement Monitoring, TrueGuide, or TrueTractor is active.

Measurement	Explanation
Hitch to Ground Contact Point	Measured from the tractor hitch pin to the soil engagement point that the implement rotates about. For planters this is typically the seeding units or the midpoint of several rows of tools.
Antenna Front/Back Offset	Measured from the implement working point to the center of the GPS antenna. This is used only when an GPS antenna is mounted on the implement. When using the TrueGuide system, minimize the antenna offset position. If an antenna offset is required, set the left/right offset first, then limit the offset to the forward distance of 2 m / 80" or less. Back offsets with the TrueGuide system are not accepted.
Antenna Left/Right Offset	Measured from the center of the implement to the center of the GPS antenna. This is used only when the GPS antenna is mounted on the implement. When using the TrueGuide system, minimize the antenna offset positions, They should not exceed 1 m or 40".
Antenna Height	The working height of the GPS antenna on the implement. This is used only when the GPS antenna is mounted on the implement.

5. On the *Overlap* tab, choose the correct option for the infill boundary:
 - *Outer*: Uses the field boundary as the infill boundary
 - *Inner*: When running a Headland setting, this moves the boundary to the inside of the last headland pass. This allows you to run the inside patterns first before running the headland and then use the inner boundary for section / rate shutoff.
6. On the *Switches* tab, enable any implement switches that are connected to the Field-IQ system. Tap **Setup**. The *Add/Edit Implement Lift Sensor* screen displays.

Setting	Explanation
Status	Off: No Switches are attached to the Field-IQ system. On: One or more implement switches are attached to the Field-IQ system.
Number of Switches	Select the number of implement switches that are attached to the Field-IQ system. The maximum is 3.
Minimum Changed Switches	Enter the number of implement switches the system should recognize to determine if the implement is lifted. For example, if the total number of switches is 2, and the Minimum Changed Switches is 2, both switches must show raised before determining the implement is in the raised position.

Field-IQ system setup



1. At the *Configuration* screen, select  Field-IQ and then tap **Setup**.
2. Tap the appropriate button to continue setup.

Button	Tap to...
Material Setup	Set up a predefined list of materials to use in the <i>Control Setup</i> or <i>Material Assignment</i> screens. See Material setup (page 219) .
Control Setup	Set up control locations and assign Field-IQ system modules. See Control setup (page 222) .
Material Assignment	Assign materials that were set up in the <i>Material Setup</i> screen to the Locations that were set up in the <i>Control Setup</i> screen.

Material setup

When you select a material from the Available Materials list, some of its specific settings appear on the right-hand side of the screen. This allows you to check some of the settings needing to view the material.

Add or edit a material

Enter information about the material.

1. At the *Material Setup* screen, tap **Add**. The *Material Details* screen displays.
2. At the *Material* tab, enter the appropriate settings and tap **Next**. See [Material tab \(page 222\)](#).
3. At the *Alarms* tab, enter the alarm information and tap **Next**. See [Alarms tab \(page 219\)](#).
4. At the *Operation* tab, complete the settings and tap **Next**. See [Operation tab \(page 220\)](#).
5. At the *Coefficient* tab, enter the calibration value with the material. The material may have different calibrations for different locations. This means that you will need to make a different material for each location and name them in such a way (for example, Wheat Front Bin, Wheat Rear Bin) that you will know which location to use them in. When you have entered the coefficient, tap **OK**.

See [Coefficient tab \(page 221\)](#).

Delete a material

1. At the *Material Setup* screen, tap **Delete**.
2. To remove the material, tap **Remove**. A message displays prompting you to tap either:
 - **Remove** to remove the material.
 - **Cancel** to return to the *Material Setup* screen.

Alarms tab

Setting	Alarm triggers when...
High Alarm	The rate reaches the selected percentage above the target for longer than the delay setting
Low Alarm	The rate drops the below the target for longer than the delay setting for the selected percentage
Singulation Low	The singulation reaches a percentage lower than 100% for longer than the delay setting
Seeds When Off	This percentage of seeds is detected while the sections are off

Setting	Alarm triggers when...
	for longer than the delay setting
No Seeds When On	This percentage of seeds is not detected for longer than the delay setting
Blockage Sensitivity/Alarm	When less than this amount of material is sensed for the number of seconds given. When no pulses are sensed for this amount of time the alarm triggers.
Multiples Threshold	When two seeds fall within this percentage of seed spacing (this is considered a double). Lowering this number requires seeds to be closer together to be reported as a double.
Skips Threshold	If two seeds fall outside of this percentage of seed spacing (this is considered a). Raising this number requires seeds to be further apart to be a skip.
Averaging Sample Size	The number of seeds used to calculate the average. Increasing this amount makes the response slower but more stable.
Misplaced Seeds Threshold	If a seed falls outside this percentage of seed spacing then it is considered misplaced and reduces the spacing quality.

Operation tab

Setting	Explanation
Jump Start Speed	The speed to be used when the master switch on the Field-IQ system master switch box is put in the jump start position. This manual override option can be used to operate the system when the vehicle is stationary. Jump start is also used when GPS has become unavailable.
Jump Start Timeout	Time that Jumpstart speed will be active. A timeout setting for the Jump Start Speed, which allows you to run the jump start for a specified amount of time. Auto control resumes if Jump Start Speed is exceeded by Ground Speed.
Shutoff Speed	This setting will shut the control system down when the vehicle reaches a minimum speed.
Minimum Override Speed <i>Note – Not available if pressure limiting is enabled.</i>	Setting used to hold the operating speed at a preset minimum to prevent the control system from operating out of a controllable range. Maintains the application rate when the implement's actual speed drops below the value entered. It is

Setting	Explanation
	used to ensure consistent material flow during slow speeds.
Apply Latency to Boundary Note – Only applies to fields that have a boundary.	This setting is also applied when you exit an exclusion zone and return to the workable area of the field. <ul style="list-style-type: none"> • Yes: The system starts when needed to begin applying immediately when crossing a boundary. • No: The system starts when the boundary is reached and any mechanical delay could leave a gap between the boundary and where the product is applied. When GPS accuracy is low, this is the preferred selection.
Rate Snapping	Due to pump constraints, liquid flow generally is inconsistent with the information on the FM-1000 Plus application. Enabling this setting gives you a more steady reading of the applied rate. If you are within the allowable error, you will see the applied rate just show your target rate.

Coefficient tab

The material may have different calibrations for different locations. This means that you will need to make a different material for each location and name them in such a way (for example, Wheat Front Bin, Wheat Rear Bin) that you will know which location to use them in.

1. Enter the coefficient.
2. Tap **OK**.

Control setup



The first time you tap **Control Setup**, the *Control Setup* screen is blank and you can only add a location.

After you have added a location, you can select it from the Location list on the right-hand side of the screen to see the assigned modules.

Button	Tap to...
Add	<p>Add and set up a new control location. This opens the <i>Control Details</i> screen, which contains the following tabs:</p> <ul style="list-style-type: none"> • Material tab (page 222) • Layout (page 224) • Section Control tab (page 225) • Rate Control tab (page 230) • Row monitoring (page 237) • Sensor tab (page 237)
Edit	View or edit the details of an existing control location.
Delete	<p>Delete an existing location. A message displays prompting you to tap either:</p> <ul style="list-style-type: none"> • Remove to remove the material • Cancel to return to the <i>Control Setup</i> screen

Material tab

1. On the Material tab at the Available Materials list, select the material that will be set up in this location.

Setting	Explanation
Material Type	Select the type of material being applied: <ul style="list-style-type: none"> • Row Crop Seed • Liquid • Granular Seed • Granular Fertilizer • Anhydrous
Material Name	Name of the material
Material Units	Units to use with the selected material
Seeds Per Pound	Number of seeds per pound
Target Rate 1	Preset volume that the implement supplies when the rate switch is in position 1.  <p>Note – For liquid, granular fertilizer, NH₃, and Granular seed, enter the desired amount of material that you would like to apply. For Row Crop seed, the target rate for row crop seed is entered as Ks/a. 1 Ks/a equals 1000 seeds per acre. When entering a target rate of 25500 into the FM-1000 Plus application, type it as 25.5.</p>
Target Rate 2	Present volume that the implement supplies when the rate switch is in position 2.  <p>Note – For liquid, granular fertilizer, NH₃, and Granular seed, enter the desired amount of material that you would like to apply. For Row Crop seed, the target rate for row crop seed is entered as Ks/a. 1 Ks/a equals 1000 seeds per acre. When entering a target rate of 25500 into the FM-1000 Plus application, type it as 25.5.</p>
Rate Increment	This setting adjusts the increment that the target rate will adjust by when in rate 1 or 2.
Manual Rate Increment	Controls the aggressiveness of the rate adjustment switch when in manual rate. <ul style="list-style-type: none"> • If the valve is over active when in manual rate you need to lower the manual rate increment. • If the valve is slow to respond when in manual rate you need to increase the manual rate increment.
Minimum Rate	Sets the minimum rate increment.

Setting	Explanation
Maximum Rate	Sets the maximum rate increment. Note – If you don't want the system to be capable of applying more than 100 units, set the maximum rate to 100 units.

- If no materials are listed, create a material that you can assign. See [Material setup \(page 219\)](#).
Note – You can also assign the correct material later using the Material Assignment option, see [Material assignment \(page 396\)](#).
- Tap **Next** to go to the [Layout \(page 224\)](#).

Layout

At the Layout tab, enter information about the implement that will be used to apply the material.

Setting	Explanation
Location Name	Add a name to the ControlLocation, for example, Hoppers, Front Bin, Rear Bin, Left Saddle Tanks.
Bin/Tank Setup	<p>The system tracks how much material is left in the bin/tank, and provides a warning when the bin/tank needs to be refilled. Adjust the settings for:</p> <ul style="list-style-type: none"> Status: <ul style="list-style-type: none"> On: The system tracks the bin/tank level and provide warnings. Off: The system will not track the bin/tank level or provide warnings. Density: (Granular and granulated material only.) Used in system setup and calibration to ensure accuracy in applying product. When changing material this setting must be updated. Capacity Units: Select Default Units or Bushels. Default units will vary according to the type of material that is being applied. Bin Capacity: The amount the tank/bin holds when full. Note – Markings on tank/bin may not be accurate. Current Volume: Current volume of the product in the tank. Partial Refill: The amount of material that will be added to the bin/tank during a partial refill. Warning Level: Setting that triggers a low bin warning. The level at which a warning displays on the screen when your bin/tank reaches a set threshold.

Setting	Explanation
	<ul style="list-style-type: none"> Spinner Pulses Per Revolution: Enter the number of magnetic pick up points per revolution of the spinner. Refill Tank/Bin: Refills the tank/bin to capacity. Partial Refill Tank/Bin: Refills the tank/bin to the Partial Refill amount.
Row Offset Setup	<p>Provides additional tuning by detailing where the material will be applied in relation to the vehicle. Increase coverage accuracy by selecting one or two offsets.</p> <p>Row offsets are measured from the Application Offset value entered in the Measurements tab of the <i>Implement Configuration</i> wizard.</p> <ul style="list-style-type: none"> Number of row offsets: Use 1 row offset when coverage is applied at a single location. Use two row offsets when planting singulated seed with staggered implements. Row Offset (1 row offset): Enter the distance between the Application Offset and the row. Rear Row Offset (2 row offset): Enter the distance between the Application Offset and the rear row. Front Row Offset (2 row offset): Enter the distance between the Application Offset and the front row.
Material Controlled By	<p>You are controlling the material with:</p> <ul style="list-style-type: none"> Switch Boxes On Screen

Section Control tab

With section control, you can avoid double coverage and eliminating wasted inputs using automatic or manual section control. Section control:

- Automatically control up to 48 rows individually
- Enables you to see where you have been and what you have done with overlap detection
- Eliminates overlap by adding Tru Count Air Clutches® and Tru Count LiquiBlock™ valves

At the Section Control tab, you can set up section control as:

- Rate as Section:** To use rate control drives as section shutoffs
- Material linking:** To link primary and secondary materials
- Automatic Section Control:** Automatic section control with various section control devices

Rate as Section

The Field-IQ system can use the rate control drives as section shutoffs. For example, when going into a nonproductive or covered area the rate control drives will be commanded to zero rate.

1. To set up rate as sections, at the Section Control tab, complete these settings.

Setting	Explanation
Section Control	Select Rate as Section.
Section Control	Tap Setup to adjust latency and overlap values.

2. Select the Rate Control tab and then set up rate control.

Material linking

The Field-IQ system can link primary and secondary materials, where the secondary material uses the output of the primary material. For example, LiquiBlock valves can be linked to use the output of Tru Count Air Clutch systems.

When planting, seeding, or strip-tilling, you can link the following together:

- Liquid
- Granular seed
- Granular fertilizer

Note – Anhydrous cannot be linked.

When the system is in diagnostics mode:

- The secondary material is not functional.
- You can only operate a linked material when you also open the sections of the primary material.

1. To link materials, at the Section Control tab, complete these settings.

Setting	Explanation
Section Control	Select Link to Material.
Linked Material	Select the primary material you want to link to.

2. Select the *Rate Control* tab and then set up rate control.

For more information, see the sections for each type below.

Automatic Section Control

The Field-IQ system can perform automatic section control using:

- Air clutch (such as Tru Count Air Clutch) or electric clutch: Used for TC and John Deere row command clutches that require inverted switching. (Signal to shut row off)
 - Boom valves: Used for 3 wire boom valves and 2 wire solenoid valves that require a 12v signal to open.
 - LiquiBlock valves (such as Tru Count LiquiBlock valves): Used for Liquiblock valves that require inverted switching.
 - Various section control devices
1. At the Field-IQ Setup screen on the Section Control tab, for:
 - a. Section Control: Select On.
 - b. Section Control Module Location: Tap **Setup**. The *Section Control Module Setup* screen displays.
 2. Complete the settings for:
 - Number of Modules: The total number of modules that will be used on the current control location.
 - Module: Assign the serial numbers of the modules to their location on the current control location.
Note – Sections start from left to right in their numbering. This means that Section 1 is on the far left and numbers increase to the right.
 - Number of Sections: The number of sections physically wired into the selected module serial number.
 3. If you have a row crop, tap Section Grouping. Otherwise tap Section Widths.
 4. Set up the section widths.
Note – Both of these setups allow you to set the section widths. Section Grouping does it by grouping rows together in a section and Sections Widths allows you to enter an actual measurement.
 - a. For section grouping, at the Section Grouping screen: Complete each row from the left and to right in sequence until all the rows are grouped correctly and then tap **OK**.

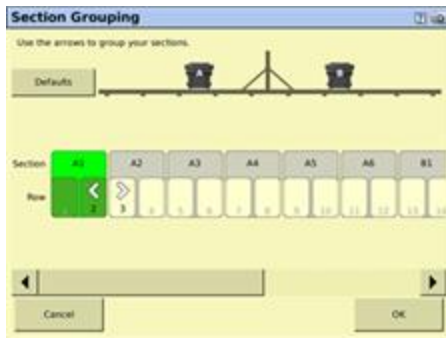

For section widths, at the Section Widths screen: Enter the section width for each section from left to right in sequence.



b.

When you are finished, tap OK.

- At the *Section Control Module Setup* screen, tap **Advanced Wire Assignment**.

Note – This button is only available for specific cases, so may not be visible.

Assign the rows to the correct module and wire location. To assign a wire ID to a row, tap the module icon, select the number of the wire you want to assign from the drop-down list, and then tap on the row to assign that module and wire. It is recommended that you work from left to right:

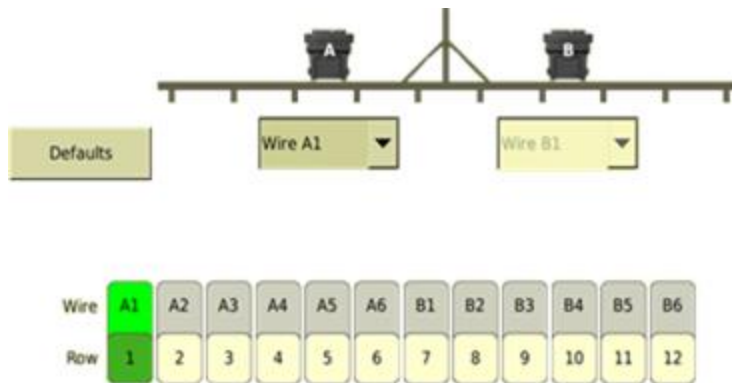

Latency

Setting	Explanation
On Latency	By default, this is set to 0.0 seconds. Use this setting unless you are experiencing a long response time from your clutch or valve (this can happen on larger systems). In this case, increase the On Latency value to compensate the delay, and the system will turn on in advance.
Off Latency	By default, this is set to 0.0 seconds. Use this setting unless you are experiencing a long response time from your clutch or valve (this can happen on larger systems). In this case, increase the Off Latency value to compensate for the delay, and the system will turn off after the set number of seconds.

Overlap

Setting	Explanation
Start Overlap	Distance of intentional swath overlap when entering a previously applied area. The higher the number, the greater the overlapped area.
End Overlap	Distance of intentional swath overlap when exiting a previously applied area. The higher the number, the greater the overlapped area.
Coverage Switching Overlap	Percentage of the section width for intentional swath overlap. The higher the number, the greater the overlapped area before the section is turned off.
Boundary Switching Overlap	Percentage of the section width for intentional overlap of a boundary. The higher the number, the greater the overlapped area into the boundary area.

Rate Control tab

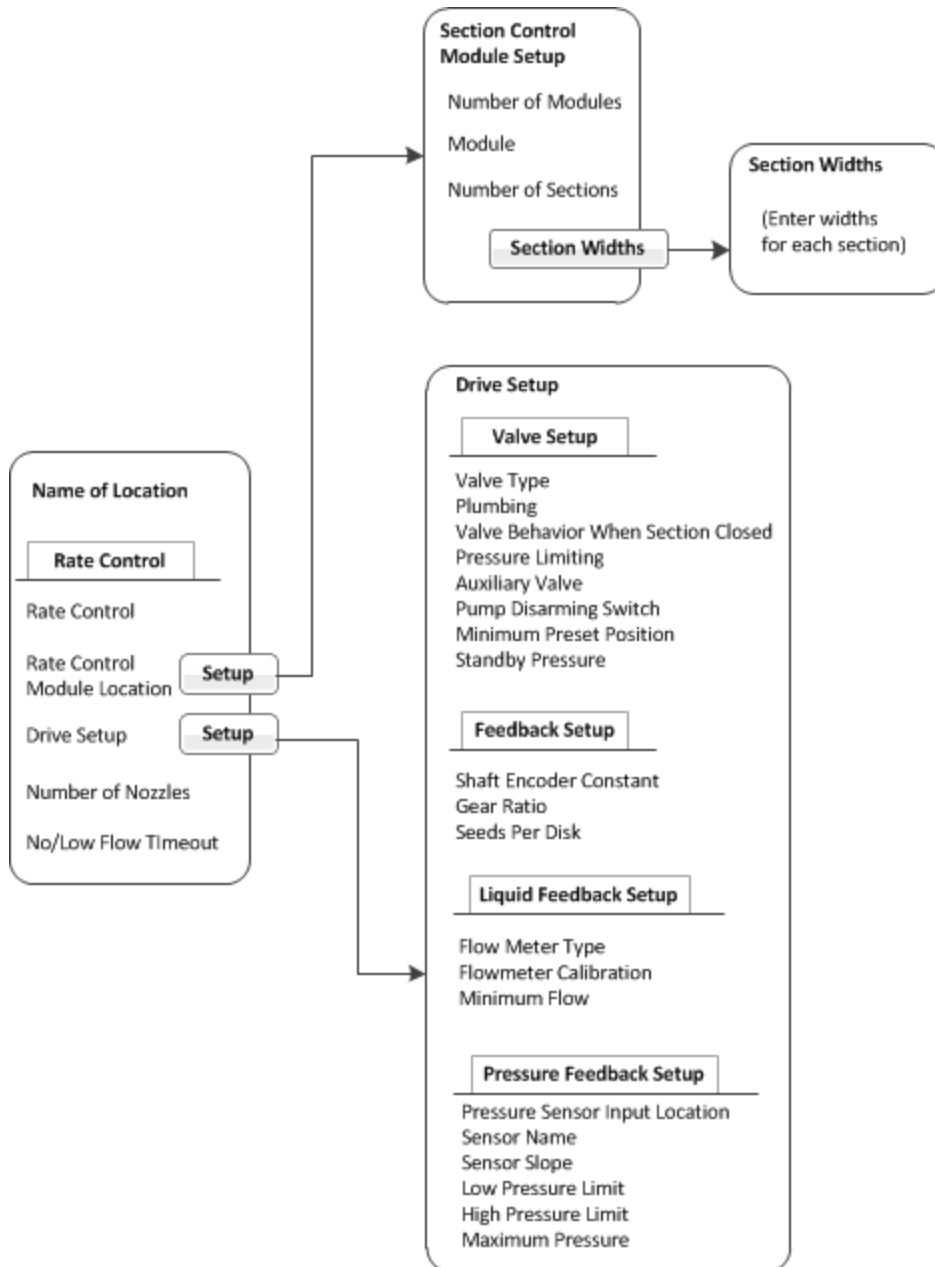

At the Rate Control tab, complete the settings based on your configuration.

Setting	Explanation
Rate Control	Select ON to have the Field-IQ system operate a rate control component. The system sets the target rate. Select OFF for no rate control. Section switching only.
Rate Control Module Location	Tap Setup to configure the rate control module(s), their location on the implement, and the width they will control. See Rate control module setup (page 232)
Drive Setup	Tap to set up the drive. The Drive Setup screen (page 233) displays. Complete the settings on each tab.
Number of Nozzles	The number of nozzles on the implement.
No/Low Flow Timeout	This is the time for which the system will attempt to control the rate. Should no response be seen, the control system will shut the channel off.

Rate control module setup

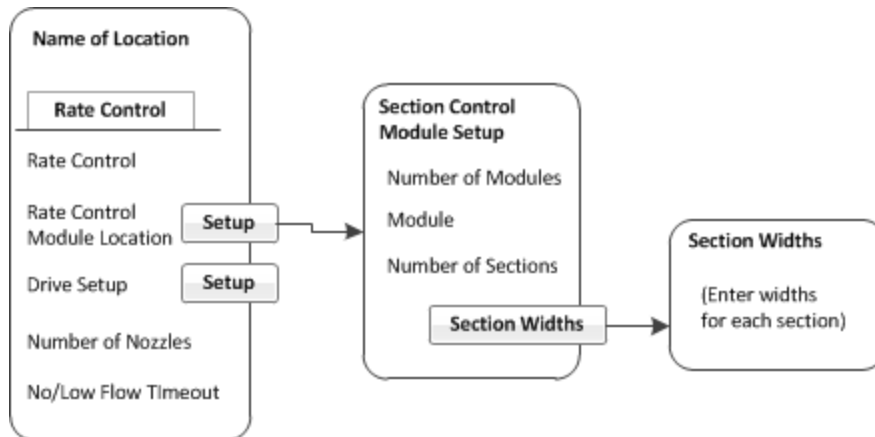

Click **Setup** next to Rate Control Module Location. The *Section Control Module Setup* screen displays.

Setting	Explanation
Number of Modules	The number of modules
Module	Select the module to configure
Number of Sections	The number of sections for the module.
Section Widths	Tap to open the Section Widths screen .

Section Widths screen

At the *Section Widths* screen enter the width of each section.

Drive Setup screen

Valve Setup tab

Setting	Option Available with Valve Types:	Explanation
Valve Type	N/A	<p>Servo: 2-wire standard servo valve that turns a ball or butterfly valve to adjust product flow</p> <p>Fast Servo: 4-wire servo valve motor that turns a ball or butterfly valve to adjust product flow</p> <p>PWM: 2-wire PWM valve. An electric solenoid valve that adjust hydraulic flow to a motor. The valve adjusts application rate indirectly.</p> <p>Pump Servo: An electric solenoid valve that adjust hydraulic flow to a motor. The valve adjusts application rate indirectly.</p> <p>Linear Actuator: A valve that creates a linear motion (as opposed to a rotary motion)</p> <p>Electric over Hydraulic: A valve that uses electric current to control the hydraulic valve output</p> <p>Hardi % Bypass: Specific system type for Hardi control systems which has a boom line leak back to tank.</p>
Plumbing	Servo Fast Servo Pump Servo Hardi % Bypass	<p>Inline: Valve is in the solution line going to the boom. The valve opens to increase the application rate.</p> <p>Bypass: Valve is in the return-to-tank line. The valve closes to increase the application rate.</p> <p>If you chose this option, Lock In Standby Pressure is available to enable.</p>
Valve Behavior When Sections Closed	All	Close: When all sections are off, the control valve returns to the closed position.
	All	Lock in Last Position: When all sections are off, the control valve remains in the last position. This setting allows the system to return to the target rate faster. The valve will remain locked in the position it was in when the boom sections were closed.
	PWM	Lock in Minimum: The valve will lock into a minimum position that is configured in setup. With this option, enter the

Setting	Option Available with Valve Types:	Explanation
		Minimum Preset Position .
	Servo Fast Servo Pump Servo PWM Hardi % Bypass	Lock in Standby Pressure: Used for maintaining a minimum operational pressure which enables a quicker response when activating sections. When sections are closed, this option can be used. If you choose this option, enter the Standby Pressure later.
Pressure limiting (page 214)	All	Enable: Pressure limiting is enabled. With this option, the Pressure Feedback Setup tab is available. Disable: Pressure limiting is not enabled. Use when no auxiliary valve is installed. See Pressure limiting (page 214) . Note – Pressure limiting (page 214) only works when the sections are on.
Auxiliary Valve	All	Master: Valve closes when the system is turned off. Dump: Valve opens to dump flow-to-return line when the system is turned off. Disable: Auxiliary valve not used or disabled.
Pump Disarming Switch	All	Enable: Select if you have a pump disarming switch installed. Disable: Select you do not have a pump disarming switch installed.
Minimum Preset Position	PWM	Only available if you have chosen PWM for the valve type and Lock in Last Position for Valve Behavior on Sections Closed .
Standby Pressure	Servo Fast Servo Pump Servo PWM Hardi % Bypass	Enter the psi. When you exit a boundary, nonproductive exclusion zone or previously covered area, the system will hold the desired pressure. When you enter a productive area again that you want to spray, there will be adequate pressure to keep a good nozzle spray pattern. Required if you selected Lock in Standby for Valve Behavior on Sections Closed .

Servo, Fast Servo, Pump Servo or Hardi % Bypass valve setting options

If you choose Bypass for Plumbing, Lock In Standby Pressure is an available option for Valve Behavior when sections closed when sections closed. If you choose Lock In Standby Pressure for Valve Behavior when sections closed, enter the Standby Pressure.

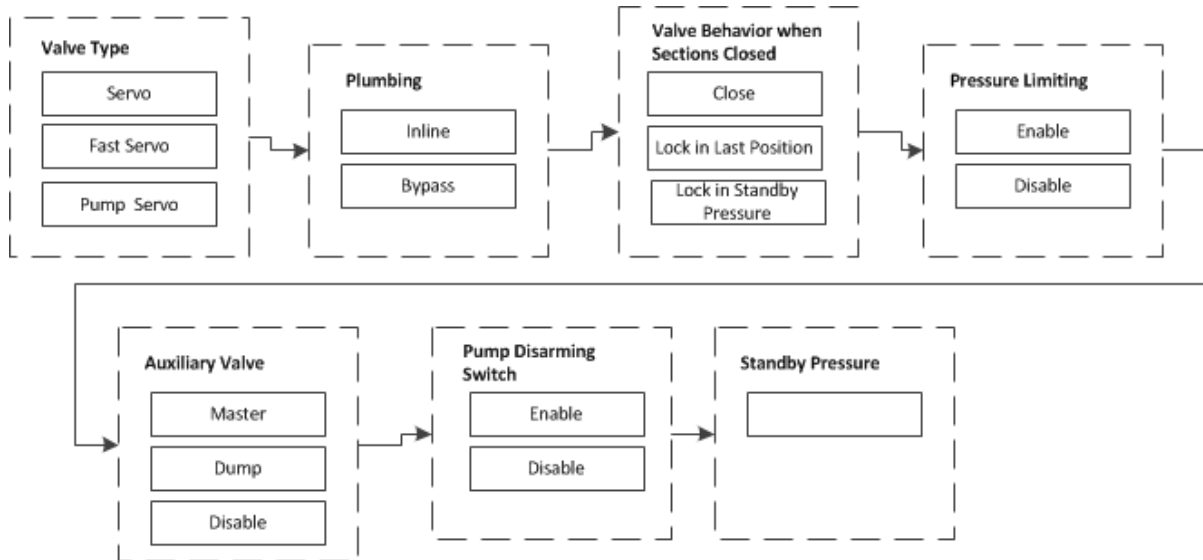

PWM valve setting options

If you choose:

- Lock in Minimum for Valve Behavior when sections closed, enter the Minimum Preset Position later
- Lock In Standby Pressure for Valve Behavior when sections closed, enter the Standby Pressure later

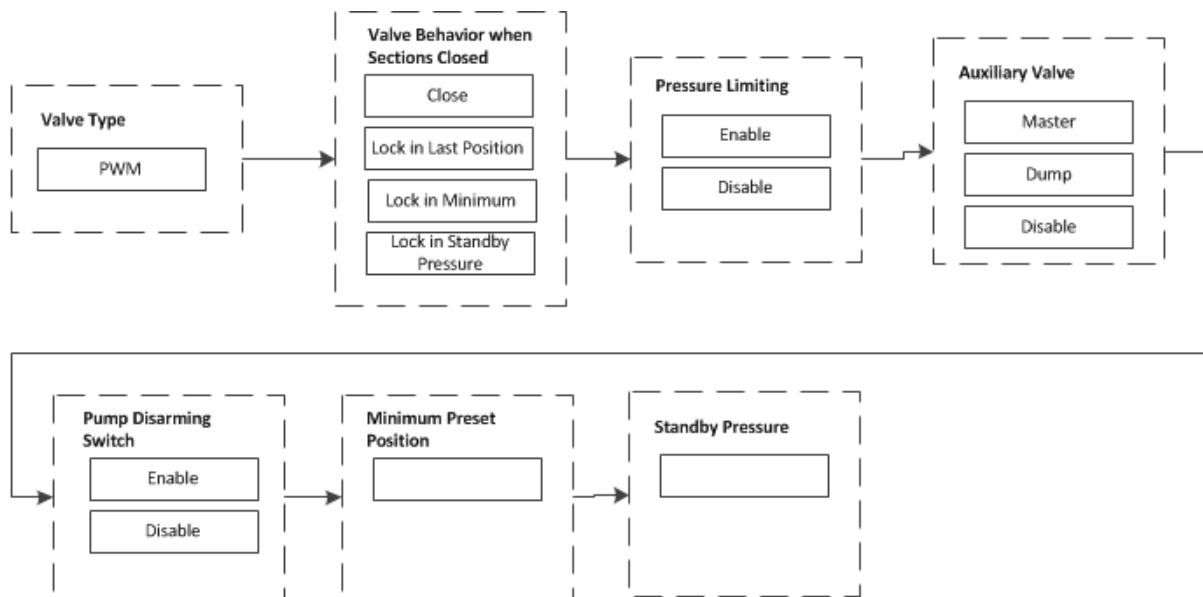

Feedback Setup tab

Setting	Explanation
Shaft Encoder Constant	Pulses per revolution.
Gear Ratio	<p>Actual ratio of the application rate sensor to the seed meter shaft RPM. This is the number of revolutions the application rate sensor turns for each revolution of the seed meter.</p> <p>The Gear ratio allows the system to properly figure the meter RPM.</p> <ul style="list-style-type: none"> • Calculate the gear ratio from the encoder to the metering point of the material. • Rawson gear ratio should be calculated from the motor to the metering point of the material <p>If the gear ratio is calculated incorrectly, the system may over or under apply even though it is showing the correct rate on the screen. You may also have issues in the <i>Drive Calibration</i> screen.</p>
Gear Ratio	Use the calculator (tap Gear Ratio Calculator) to determine your gear ratio.
Seeds Per Disk	The number of seed openings per disk plate.

Liquid Feedback Setup tab

Setting	Explanation
Flow Meter Type	Select the type of flow meter you are using.
Flowmeter Calibration	Enter the number for the flow meter calibration.
Minimum Flow	If you have enabled pressure limiting on the Valve setup tab, pressure limiting takes precedence over this setting. This may result in the system operating below minimum flow.

Pressure Feedback Setup tab

Setting	Explanation
Pressure Sensor Input Location	Select either Pressure 1 or Pressure 2.
Sensor Name	Optional name for the pressure sensor.

Setting	Explanation
Sensor Slope	
Low Pressure Limit	This option is only available if you enabled Pressure Limiting at the Valve Setup tab.
High Pressure Limit	This option is only available if you enabled Pressure Limiting at the Valve Setup tab.
Maximum Pressure	

Row monitoring

Setting	Explanation
Row Monitoring	<ul style="list-style-type: none"> • Disabled: Row monitoring is turned off. • Blockage: Select when using an air seeder or when applying granular material. • Seed Count: Select for precision seeding.
Setup	<ul style="list-style-type: none"> • Row Sensor Enable: Turn individual row sensors on or off. • Row Sensor Wiring: Select which wire each row sensor is wired to.

Sensor tab

At the *Sensor* tab, you can add alarm functionality to a sensor. You can also access the *Sensor Setup* screen, where you can add, edit, or delete sensors.

Setting	Explanation
Sensor Type	The required sensor for which you want to create an alarm.
Name	Displays after you have selected the sensor type. You can enter a name for the sensor.
Alarm	Enabled: Alarm is enabled Disabled: There is no alarm
Warn if below	If less than this threshold and longer than the delay time, the alarm will display.
Warn if above	If more than this threshold and longer than the delay time, the alarm will display.
Warn after	Delay time for the threshold values:

Setting	Explanation
	<ul style="list-style-type: none"> Warn if below Warn if above
Sensor Setup	Tap to access the Sensor Setup screen.

Sensor Setup screen

At the *Sensor Setup* screen, you can add, edit or remove a sensor.

When adding or editing a sensor, enter the following information.

Setting	Explanation
Sensor Type	<ul style="list-style-type: none"> Air pressure/vacuum Liquid pressure NH3 pressure Bin level RPM Gate Height
Name	Enter a name for the sensor
Sensor Setup	Field-IQ module: The Field-IQ system module that is controlling this sensor. Input location: Which wire is controlling the sensor. (Not required for gate height.)
Alarm	Alarm settings

Equipment calibration for Field-IQ

Calibrate the equipment for your setup:

- [Anhydrous calibration \(page 240\)](#)
- [Air Seeder calibration \(page 239\)](#)
- [Planter calibration \(page 242\)](#)
- [Sprayer calibration \(page 246\)](#)
- [Spreader calibration \(page 251\)](#)

Air Seeder calibration



WARNING – Moving parts during this operation. Ensure the implement is safe to operate.

To calibrate an air seeder calibrate the implement lift switch, then the modules.

For a spreader or seeder: Minimum and maximum motor RPM are used to keep the motor within the manufactures recommended operating range. Rawson specs are 150 and 500 RPM.

Implement lift switch calibration

1. At the *Field-IQ Calibration* screen, select **Implement Lift**.
2. Raise the implement and then tap **Next**.
3. Lower the implement and then tap **Next**.
4. Tap **OK** to return to the *Field-IQ Calibration* screen.

Modules calibration

Calibrate the modules to ensure that your system performs at the level you require.

Note – If you have an implement lift switch, calibrate it first.

The Field-system *Calibrate* option only displays on the *Configuration* screen if you have at least one Field-IQ system Rawson control module or Rate control module set up to control the rate.

1. At the *Configuration* screen, select  Field-IQ and then tap **Calibrate**.
2. At the *Field-IQ Calibration* screen, select the operation listed under the module that you want to calibrate. The message **Not calibrated** displays at the end of the modules that need calibration.

Note – Calibration screens will vary slightly if you are using a linear actuator.

Note – Before priming the system, the Automatic / Manual Switch on the master switch box must be in the manual position.

3. Tap **Drive Calibration** and then tap **OK**. The *Drive Calibration* screen displays. Enter the appropriate settings.

Tab	Explanation
Drive Limits	Enter the minimum and maximum flow values.
Auto-Tuning	Moving parts during this operation. Ensure that the implement is safe to operate. Follow the on-screen instructions to auto-tune the system. Do not perform the auto-tuning function if you have loaded a preset configuration file. Use the predefined configuration settings appropriate for your vehicle.
Drive Settings	Turn the master switch on and vary the rates. Adjust values if needed.
Info	Shows the results and drive limits of your calibration.

4. Select Flow Calibration and then tap **OK**. The *Flow Calibration* screen displays.

Anhydrous calibration



WARNING – NH₃ is an irritant and corrosive to the skin, eyes, respiratory tract and mucous membranes, and is dangerous if not handled properly. It may cause severe burns to the eyes, lungs, and skin. Skin, and respiratory-related diseases could be aggravated by exposure. It is recommended that protective gloves, boots, slicker and/or pants and jacket, and chemical-splash goggles that are impervious to anhydrous ammonia are worn at all times.



WARNING – Anhydrous valve and flow calibrations require the vehicle and implement to be moving and the implement must be in the ground (the implement lift switch must be down). Take all necessary precautions to ensure user safety. Failure to do so may result in serious injury or death.

To calibrate anhydrous, first calibrate the implement lift switch. Then calibrate the modules to ensure your system performs at the level you require.

Implement lift switch calibration

1. At the *Field-IQ Calibration* screen, select Implement Lift.
2. Raise the implement and then tap **Next**.
3. Lower the implement and then tap **Next**.
4. Tap **OK** to return to the *Field-IQ Calibration* screen.

Module drive calibration

The anhydrous valve calibration requires the vehicle and implement to be moving and the implement must be in the ground (the implement lift switch must be down). Take all necessary precautions to ensure user safety. Failure to do so may result in serious injury or death.

The Field-IQ system Calibrate option only displays on the *Configuration* screen if you have at least one Field-IQ system Rawson control module or Rate control module set up to control the rate.

1. At the *Configuration* screen, select Field-IQ and tap **Calibrate**.
2. At the *Field-IQ Calibration* screen, select the operation under the Module that you would like to calibrate. The message "Not calibrated" displays at the end of the modules that need calibration.

Note – *If you have an implement lift switch, calibrate it first.*

3. Select Drive Calibration and tap **OK**. The *Drive Calibration* screen displays.
4. At the Drive Limits tab, enter the minimum and maximum flow valves and tap Next.
5. At the Drive Settings tab, turn the master switch on and vary the rates. Adjust the values if needed. Enter the values for:
 - Allowable Error
 - Integral Gain
 - Minimum Response
6. Tap **Next** and enter the following values for:
 - Allowable Error
 - Gain
 - Minimum Response

Note – *For information about the appropriate values for your sprayer, refer to the support note Field-IQ crop Input Control System: For Sprayers and Spreaders.*

Module flow calibration

1. At the *Field-IQ Calibration* screen, select Flow Calibration and tap **OK**.
2. At the *Rate and Section Control Flow Calibration* screen, enter values for:
 - Flow Meter type
 - Flow Meter Calibration
 - Minimum Flow
3. Tap **Run Calibration** and follow the on-screen instructions.

Planter calibration

The calibration process for a planter includes:

- [Implement lift switch calibration \(page 242\)](#)
- [Rawson modules calibration \(page 242\)](#)
- [Hydraulic test \(page 243\)](#)
- [PWM valves calibration \(page 244\)](#)

Implement lift switch calibration



WARNING – Moving parts during this operation. Make sure that the implement is safe to operate.

1. At the *Field-IQ Calibration* screen, select **Implement Lift**.
2. Raise the implement and then tap **Next**.
3. Lower the implement and then tap **Next**.
4. Tap **OK** to return to the *Field-IQ Calibration* screen.

Rawson modules calibration

Note – If you have an implement lift switch, [calibrate it first](#).

Calibrate the modules to ensure that your system performs at the level you require.

Note – You must have at least one Field-IQ system Rawson control module or Rate control module set up to control the rate before the Field-IQ **Calibrate** button will display on the Configuration screen.

1. At the *Configuration* screen, select  Field-IQ and tap **Calibrate**. The *Field-IQ Calibration* screen displays.
2. Select the first module that you want to calibrate. The *Planter Calibration* screen displays.
Note – If a Rawson module was configured, the correct calibration is selected automatically.
3. Complete the settings.

Setting	Explanation
Seeds Per Disk	The number of seed openings per disk plate
Gear Ratio	Tap Calculate to determine the gear ratio. Allows the system to properly figure the meter RPM. The number of revolutions that the application rate sensor turns for each revolution of the seed meter.

Setting	Explanation
	<p>Calculate the gear ratio from the encoder to the metering point of the material.</p> <p>Calculate the Rawson gear ratio from the motor to the metering point of the material.</p> <p>Note – <i>If the gear ratio is figured incorrectly, the system may over or under apply, even if it is showing the correct rate on the screen. You may also have issues in the drive calibration screen.</i></p>
Calibration Constant	A calculated value the system determines during calibration. To begin, leave the value at 1.000. After the calibration test, the system may adjust this value.

- Place a clean empty container under the rows that contain seeds to capture the seeds dispensed during the calibration.



WARNING – Moving parts during this operation. Ensure the implement is safe to operate.

- Tap **Test**.
- The system asks if you would like to prime the system. Tap **Yes**. To ensure that the seed disk is full, the system turns the seed disks one revolution.
- Turn on the master switch to prime the system and then when prompted on-screen, turn off the master switch.
- For Number of Seed Meter Revolutions, enter a value and tap **Start**. The higher the number of revolutions the more accurate the calibration. Five to 10 revolutions is recommended.
- Follow the on-screen prompts of operating the master switch. After the system turns the specified number of revolutions, enter the number of seeds dispensed per row and then tap **Continue**.
- The next screen shows the minimum and maximum speeds for the target rate specified. Tap **OK** and then either press **Test** to repeat the calibration or tap **OK** to continue.
- Select the **Limits** tab to view a listing of the limits that are set.
- Tap **OK**.
- Repeat the previous steps for other Rawson Control Modules that need calibration.

Hydraulic test

The purpose of this test is to exercise the hydraulics to establish whether there is sufficient oil flow to run the system. The Rawson hydraulic test is used to make sure the drive will turn. After entering a desired RPM the master switch is turned on and the drive should begin to turn.

If the drive does not turn, check all electrical connections. If the motor is plugged in properly, it will make a hissing or whining noise.

1. Check that there is hydraulic flow to the Rawson.
2. At the *Field-IQ Calibration* screen, tap **Hydraulic Test**.



WARNING – Moving parts during this operation. Ensure the implement is safe to operate.

3. Tap **Next**.
4. Enter the initial motor RPM. The default setting is 300. It is recommended that you test the motor RPM at 100 to ensure that the drive runs smoothly at slow speeds.
5. Tap **Start**. The next screen provides the status of each motor:
 - No Error: The test was successful.
 - Motor Stalled: The motors did not have sufficient oil flow. Ensure the correct orifice size is installed for each motor. For more information, refer to the *Rawson System Installation Instructions*.
 - Disconnected: The Rawson Control Module cannot communicate with the motor.
6. Tap **Stop** to return to the *Field-IQ Calibration* screen.

PWM valves calibration

Drive Calibration

1. At the *Field-IQ Calibration* screen, select Drive Calibration. The *Field-IQ Drive Calibration* screen displays.
2. On the Drive Limits tab, enter the values for:
 - Minimum Seed Disk RPM
 - Maximum Seed Disk RPM

Tap **Next**.

3. On the Auto Tuning tab, follow the instructions to auto tune the system.

Note – Do not perform the auto tuning function if you have loaded a preset configuration file. Use the predefined configuration settings appropriate for your vehicle.



WARNING – Moving parts during this operation. Ensure the implement is safe to operate.

During the auto tuning process the system tries to control the drive with in the specified RPM limits.

If the calibration fails, the drive may have not been able to meet the limits you entered on the Drive Limits tab.

For a liquid system, it may be helpful to remove all orifices or nozzles to let the system flow freely.

4. When the auto tuning is finished, tap **Next**.
5. On the *Drive Settings* tab, turn the master switch on and vary the rates. Then adjust the values on this tab, if necessary.
6. Tap **Next**. On the *Info* tab, the results and drive limits of the calibration are listed. This screen is used to show the applicators operating range. If the speeds that are displayed are not logical, there is a setting issue. You may also need to perform a catch test for these numbers to be accurate.

Flow Calibration



WARNING – During flow calibration, the machine will become operational. Take all necessary precautions to ensure user safety. Failure to do so may result in serious injury or death.

Flow calibration is used to check the accuracy of the:

- Gear ratio (if applicable)
- Gate settings (if applicable)
- App rate sensor



WARNING – Moving parts during this operation. Ensure the implement is safe to operate.

This is done by performing a catch test.

1. At the *Field-IQ Calibration* screen, select *Flow Calibration* under the valve you want to calibrate. The *Planter Calibration* screen displays.
2. On the *Calibrate* tab, complete the settings.

Setting	Explanation
Seeds Per Disk	The number of seed openings per disk plate.
Shaft Encoder Constant	Pulses per revolution.
Calibration Constant	A calculated value that the system determines during calibration. This field allows you to adjust for inconsistencies in the seed meters. To start out, leave the value at 1.000. After the calibration test, the system may adjust this number.

3. Tap **Test** and follow the instructions to test the settings you entered.
4. On the *Limits* tab, you can view an overview of the limits that are set.

Sprayer calibration



WARNING – Moving parts during this operation. Ensure the implement is safe to operate.

To calibrate a sprayer calibrate the implement lift switch, then the modules.

Implement lift switch calibration

1. From the *Field-IQ Calibration* screen, select Implement Lift.
2. Raise the implement and then tap **Next**.
3. Lower the implement and then tap **Next**.
4. Tap **OK** to return to the *Field-IQ Calibration* screen.

Spraying modules calibration

Calibrate the modules to ensure that your system performs at the level you require.

The option to calibrate the Field-IQ system only displays on the *Configuration* screen if you have at least one Field-IQ system Rate and Section control module installed.

1. At the *Configuration* screen, select  Field-IQ and then tap **Calibrate**.
2. At the *Field-IQ Calibration* screen, select the Rate and Section Control module you want to calibrate.

Note – If you have an implement lift switch, calibrate it first.

Drive Calibration

At the *Field-IQ Drive Calibration* screen, complete the settings on each tab.

Drive Limits tab

Settings	Explanation
Maximum Flow	Set the maximum flow on your system to prevent it from operating outside its capability. If you do not know the maximum limit of the system, leave this set to zero to ensure accurate auto tune limits are calibrated.
Maximum Pressure Note – Displays if Pressure limiting (page 214) is enabled.	The system shows the Maximum Pressure Limit set in the <i>Drive Setup</i> screen (launched from the Rate Control tab) on the Pressure Feedback Setup tab. See Rate Control tab (page 230) . Any changes you make to this value will also be changed on the Pressure Feedback Setup tab.

Auto-Tuning tab

At this tab, turn the master switch on to begin the auto calibration process. When the progress bar has completed, turn the master switch off, and tap **Next**. All rows and sections will be commanded fully open during this process.

If you need to shut down the drive at any time, switch the master switch to the off position and adjust the rate and speed parameters on the [Drive Limits tab](#) as necessary.

If pressure limiting is:

- Disabled: The calibration process will show the status of the master switch and the current flow.
- Enabled: The calibration process will show the status of the master switch, the current flow and the current pressure.

Drive Settings tab

Settings	Explanation
Target Speed	Enter the test speed to use during calibration. The system will apply material at the rate required to reach the Target Rate if the vehicle travels at this speed.
Target Rate	Display only.
Applied Rate	The applied rate for comparison to the Target Rate.
Master Switch	Status of on or off. Display only.
Current Pressure	Available if Pressure limiting (page 214) is enabled or if Lock in Standby Pressure is chosen for Valve Behavior when sections closed in the <i>Drive Setup</i> screen (launched from the Rate Control tab) on the Pressure Feedback Setup tab. See Rate Control tab (page 230) .
Proportional Gain	If the drive is slow to come up to rate, increase the Proportional Gain and turn on Boost (Feed Forward). If the applied rate is erratic, decrease the Proportional Gain.
Minimum Response	If the drive is not responding, increase the Minimum Response. If the system has large fluctuations in applied rate, decrease the minimum response.
Allowable Error	If the Applied Rate is less than this amount away from the target rate, the system will not send commands to adjust the rate.
Boost (Feed Forward)	If the drive is slow to come up to rate, increase the Integral/Proportional Gain and turn on Boost (Feed Forward).
Advanced Parameters	Tap to launch the advanced parameters.

Advanced parameters

Advanced Tuning tab

Settings	Explanation
Target Speed	Enter the test speed to use during calibration. The system will apply material at the rate required to reach the Target Rate if the vehicle travels at this speed.
Target Rate	Display only.
Applied Rate	Display only.
Master Switch	Status of on or off. Display only.
Current Pressure	Display only.
Integrator Upper PWM Limit	Change only if requested by support.
Integrator Lower PWM Limit	Change only if requested by support.
Comparator Limit	Change only if requested by support.
Ramp Limit	Change only if requested by support.
Boost (Feed Forward)	If the drive is slow to come up to rate, increase the Integral/Proportional Gain and turn on Boost (Feed Forward).
Proportional Gain	If the drive is slow to come up to rate, increase the Proportional Gain and turn on Boost (Feed Forward). If the applied rate is erratic, decrease the Proportional Gain.
Integral Gain	Change only if requested by support.
Differential Gain	Change only if requested by support.
Minimum Response	If the drive is not responding, increase the Minimum Response. If the system has large fluctuations in applied rate, decrease the minimum response.
Allowable Error	If the Applied Rate is less than this amount away from the target rate, the system will not send commands to adjust the rate.
Process Gain	Change only if requested by support.
Smoothing Factor	Change only if requested by support.

Settings	Explanation
(Flow Filter Time Constant)	
Pre Position Open	Change only if requested by support.
Pre Position Stop	Change only if requested by support.

Advanced PWM tab

This tab is only available if PWM has been selected as the valve type in the *Drive Setup* screen (launched from the Rate Control tab) on the Valve Setup tab. See [Rate Control tab \(page 230\)](#).

Settings	Explanation
Target Speed	Enter the test speed to use during calibration. The system will apply material at the rate required to reach the Target Rate if the vehicle travels at this speed.
Target Rate	Display only.
Applied Rate	Display only.
Master Switch	Status of on or off. Display only.
Current Flow	Display only.
Base PWM Frequency	Change only if requested by support.
Dither Frequency	Change only if requested by support.
Dither Amplitude	Change only if requested by support.
Dither Control	Change only if requested by support.
PWM Upper Limit	Change only if requested by support.
PWM Lower Limit	Change only if requested by support.

Advanced Pressure tab

This tab is only available if [Pressure limiting \(page 214\)](#) is enabled.

Settings	Explanation
Target Speed	Enter the test speed to use during calibration. The system will apply material at the rate required to reach the Target Rate if the vehicle travels at this speed.
Target Rate	Display only.
Current Flow	Display only.
Applied Rate	Display only.
Master Switch	Status of on or off. Display only.
Integrator Upper PWM Limit	Change only if requested by support.
Integrator Lower PWM Limit	Change only if requested by support.
Comparator Limit	Change only if requested by support.
Ramp Limit	Change only if requested by support.
Proportional Gain	If the drive is slow to come up to rate, increase the Proportional Gain and turn on Boost (Feed Forward). If the applied rate is erratic, decrease the Proportional Gain.
Integral Gain	Change only if requested by support.
Differential Gain	Change only if requested by support.
Minimum Response	If the drive is not responding, increase the Minimum Response. If the system has large fluctuations in applied rate, decrease the minimum response.
Allowable Error	If the Applied Rate is less than this amount away from the target rate, the system will not send commands to adjust the rate.
Process Gain	Change only if requested by support.
Smoothing Factor (Flow Filter Time Constant)	Change only if requested by support.
Hysteresis Up	Change only if requested by support.
Hysteresis Down	Change only if requested by support.

Spreader calibration

To calibrate a spreader, first calibrate the implement lift switch. Then calibrate the modules to ensure your system performs at the level you require.

1. Implement lift switch calibration
2. At the *Field-IQ Calibration* screen, select the **Implement Lift** option.
3. Raise the implement and then tap **Next**.
4. Lower the implement and then tap **Next**.
5. Tap **OK** to return to the *Field-IQ Calibration* screen.

Rawson modules calibration

The Field-IQ system *Calibrate* option only displays on the *Configuration* screen if you have at least one Field-IQ system Rawson control module or rate control module set up to control the rate.

Note – If you have an implement lift switch, calibrate it first.

1. At the *Configuration* screen, select  Field-IQ and then tap **Calibrate**.
2. At the *Field-IQ Calibration* screen, select the module you want to calibrate.
3. Select the first module to calibrate. The *Planter Calibration* screen displays.

Note – If a Rawson module was configured, the correct calibration is selected automatically.

Setting	Explanation
Gear Ratio	Specifies the actual ratio from the application rate sensor to the seed meter shaft RPM. This is the number of revolutions the application rate sensor turns for each revolution of the seed meter.
Gear Ratio Calculator	Use the calculator to determine your gear ratio.
Calibration Constant	A calculated value that the system determines during calibration. This field allows you to adjust for inconsistencies in the seed meters. To start out, leave the value at 1.000. After the calibration test, the system may adjust this number.

4. Place a clean empty container under the rows that contain seeds to capture the seeds dispensed during the calibration.



WARNING – Moving parts during this operation. Ensure the implement is safe to operate.

5. Tap **Test**.

6. The system asks if you would like to prime the system. Tap **Yes**. To ensure that the seed disk is full, the system turns the seed disks one revolution.
7. Turn on the master switch to prime the system and then when prompted on-screen, turn off the master switch.
8. In the Number of Seed Meter Revolutions entry box, enter a value and then tap **Start**. The higher the number of revolutions the more accurate the calibration. Five to 10 revolutions is recommended.
9. Follow the on-screen prompts of operating the master switch. After the system turns the specified number of revolutions, enter the number of seeds dispensed per row and then tap **Continue**.
10. The next screen shows the minimum and maximum speeds for the target rate specified. Tap **OK** and then either press **Test** to repeat the calibration or tap **OK** to continue.
11. Tap the Limits tab to show an overview of the limits that are set for Target Rate 1, Target Rate 2 and Jump Start.
12. Tap **OK**.
13. Repeat steps 1 through 10 for other Rawson Control Modules that need calibration.

Hydraulics test

The purpose of the hydraulics test is to exercise the hydraulics to establish whether there is sufficient oil flow to run the system.

1. At the *Field-IQ Calibration* screen tap **Hydraulic Test**.



WARNING – Moving parts during this operation. Make sure that the implement is safe to operate.

2. Tap **Next**.
3. Enter the initial motor RPM. The default setting is 300. It is recommended that you test the motor RPM at 100 to ensure that the drive runs smoothly at slow speeds.
4. Tap **Start**. The next screen provides the status of each motor.

Status	Explanation
No Error	The test was successful.
Motor Stalled	The motors did not have sufficient oil flow; ensure the correct orifice size is installed for each motor. For more information, refer to the <i>Rawson System Installation Instructions</i> .
Disconnected	The Rawson Control Module cannot communicate with the motor.

5. Tap **Stop** to return to the *Field-IQ Calibration* screen.

PWM valves calibration

Drive calibration

From the *Field-IQ Calibration* screen, select Drive Calibration under the valve you want to calibrate. Enter the appropriate settings on each tab.

Tab	Explanation
Drive Limits	Enter the minimum and maximum flow values.
Auto-Tuning	Moving parts during this operation. Ensure that the implement is safe to operate. Follow the on-screen instructions to auto-tune the system. Do not perform the auto-tuning function if you have loaded a preset configuration file. Use the predefined configuration settings appropriate for your vehicle.
Drive Settings	Turn the master switch on and vary the rates. Adjust values if needed.
Info	Shows the results and drive limits of your calibration.

Flow calibration



WARNING – During flow calibration, the machine will become operational. Take all necessary precautions to ensure user safety. Failure to do so may result in serious injury or death.

The Field-IQ system *Calibration* option only displays on the *Configuration* screen if you have at least one Field-IQ system Rate and Section control module installed.

1. At the *Configuration* screen, select  Field-IQ and then tap **Calibrate**.
2. At the *Field-IQ Calibration* screen, select the Rate and Section Control Module to be calibrated. (The message Not calibrated displays at the end of the modules that need calibration.) The *Field-IQ Calibration* screen displays that includes the serial number of the rate and section control module you just selected.
3. Select Flow Calibration. The *Rate and Section Controller Valve Calibration* screen displays.
4. Select the Control tab and complete the settings for:
 - Allowable Error
 - Gain
 - Minimum Response

Note – For information about the appropriate values for your sprayer, see the Support Note - Field-IQ Crop Input Control System: For Sprayers and Spreaders.

5. Tap **OK** to return to the *Field-IQ Calibration* screen.
6. Select Flow Calibration. The *Granular Calibration* screen displays.
7. At the Calibrate tab, complete the settings.

Setting	Explanation
Gate Height Setting	Current height of the gate opening. If you entered a gate height measurement during setup, you must enter a measurement here.
Staff Encoder Constant	

8. Tap **Calculate** to calibrate the constant. The *Calibration Constant Calculator* screen displays.
9. Complete the settings.

Setting	Explanation
Gate Width	Width of the gate opening
Drag Chain Distance Per Rev	The length of the drag chain per turn of the drag shaft. To figure the drag chain length, you can either: <ul style="list-style-type: none"> • Multiply the diameter of the drag shaft by 3.14. • Mark the belt and measure the distance the mark moved after 1 revolution of the drag shaft. If these numbers are not correct, you will have issues calibrating the spreader. If any of these settings physically change in the implement, they need to be adjusted in the FM-1000 Plus application to maintain accuracy.

The system calculates the calibration constant. This value represents the liters of material dispensed from the spreader per revolution of the drag shaft assuming the gate height is 1 meter. The actual gate height is factored in later. The FM-1000 Plus application will automatically come up with this value.

10. Tap **OK** to return to the *Granular Calibration* screen.
11. Place a clean empty container under the spreader to capture the material dispensed during the calibration, and then tap **Calibrate**. The *Granular Calibration* screen displays.



WARNING – Moving parts during this operation. Ensure the implement is safe to operate.

12. Complete the settings.

Setting	Explanation
Amount of Material to be Dispensed	The amount to be dispensed during the calibration.
Target Rate	
Target Calibration	

13. To begin calibration, tap **Start** and follow the on-screen instructions.
14. Select the **Info** tab to view the system's operational limits (based on the RPM limits, target rates, and application width).
15. Tap **OK**.

GreenSeeker setup

In this chapter:

GreenSeeker functionality	258
Care and maintenance	258
Field preparations for nitrogen application	259
Field setup	260
Field preparations for user defined rate ...	261
Delivery system and liquid control	261

GreenSeeker sensors shine a calibrated light wave spectrum to measure the returned reflective light spectrum from plants, and analyze the data to determine the plants' needs for nitrogen

GreenSeeker functionality

As you travel the field, in real-time the GreenSeeker RT200 system:

- Sensors emit light at two specific wavelengths to measure the light reflected by plants.
- Analyzes the reflected light and determines the nitrogen level (NDVI - normalized difference vegetation index) of the plants below
- Sends the data to the FM-1000 Plus application

The FM-1000 Plus application sends the correct application rates to either:

- The applicator's rate controller (using Serial Rate Control)
- The Field-IQ system

The required amount of fertilizer is applied as you pass over the crop.

As materials are applied, the system logs the:

- NDVI
- Target rate
- Applied rate

Note – Some rate controllers connected via serial cable to the display do not respond with an 'As Applied' value.

For operational information, see [GreenSeeker operation \(page 422\)](#).

Care and maintenance

To maintain the high performance of your GreenSeeker RT200 variable rate application and mapping system:

- Each day or during applicator re-fill, check the GreenSeeker sensor detector and light source windows for dust and dirt, and wipe clean with a soft rag.
- Do not leave the GreenSeeker system outdoors during extreme weather conditions. Wide temperature variations are hard on electronics and fluid seals, and may reduce the operating life of the system.
- DO NOT store a GreenSeeker system with the sensors facing upward. Doing so may allow water to collect around the windows and gaskets, causing seal failures in those areas. Also direct sunlight can in some cases focus enough energy into the sensor to damage the detector.

Note – There are no field serviceable components of the electronic system; do not attempt any field repair of a malfunctioning interface module or sensors. If you experience operating problems, contact your local dealer.

Field preparations for nitrogen application

Note – The following instructions apply to the most common nitrogen applications. Check algorithms for specific instructions. For updated specific algorithm instructions, visit www.GreenSeeker.com.

Before you can use the GreenSeeker applicator to apply nitrogen across a field, before or shortly after planting you must establish a nitrogen rich reference strip (NRS) or "calibration" area. The rest of the field is referred to as the Non-Reference (Non-Ref) portion (or as the N-limited area or farmer practice region).

The NRS reference strip is used to determine the:

- Amount of nitrogen being made available to the plant by the environment (such as mineralization)
- Current year's expected maximum yield potential and response to additional nitrogen

An ideal NRS runs the length of the field, but must be at least 400 feet long.

1. Establish the NRS in a representative reference portion of the field (in other words, not in high spot or low spot). Use a permanent land marker or temporary marker to ensure that the NRS can easily be found later in the season. You may also want to establish the location of the NRS by noting it as an A-B line or flag on the screen.

The rate of nitrogen necessary to establish a NRS:

- Is crop and region dependent
 - Should be the highest rate necessary to satisfy crop needs throughout the growing season
2. Use the sensor mounted booms of the RT200 system with RT Commander or the GreenSeeker Hand Held sensor.

If past practice was a 100% pre-plant application of nitrogen, decrease pre-plant nitrogen application rate of the field to a level at least half of previous total nitrogen applied during non-GreenSeeker management practice.

Crop	Explanation
Spring or winter wheat	If application rate has historically been 100 lbs N/acre, decrease the rate to 50 lbs nitrogen per acre. Note – Sandy soil type or heavy rainfall may require additional N application to maintain the NRS as a non-limiting reference area.
Corn	If application rates have historically been 200 lbs nitrogen per acre decrease to 75 to 125 lbs N/acre. Note – Sandy soil type or heavy rainfall may require additional N application to maintain the NRS as a non-limiting reference area.

For best results, use the RT200 to "read" the NRS and apply N at growth stages dependent upon the crop algorithm used. For most supplied algorithms this is typically:

- Wheat: Feekes growth stage 4-6
- Corn: V8-V12

For updated specific algorithm instructions, see www.GreenSeeker.com. Plant coverage should be at least 50% for the sensors to accurately determine NDVI for topdressing (or sidedressing).

To collect sensor readings, pass the boom mounted sensor (or handheld sensor) over the crop at 32 — 48" above the canopy. Sense a large area of the NRS and nonreference portion of the field to accurately determine their respective NDVI values.

3. Apply an applicators width swath of N. The rate of N applied should be high enough to satisfy crop N needs in a good year.
4. Enter the values into GreenSeeker on the FM-1000 Plus application:
 - Automatically with the boom mounted sensors
 - Manually with the GreenSeeker handheld

5. If the response is variable across the field, select an area where the difference between the reference and the non-reference areas are most apparent. This assures that the algorithm will determine a rate that utilizes the highest yield potential prediction and maximum response to N for that year.

To estimate yield potential, most algorithms utilize an environmental factor (Growing Degree Days or Days From Planting), which takes into account the weather and length of time that has passed since planting.

Different GDD variations are used for different crops. You must know the planting date and sensing date to obtain the GDD value.

Field setup

To prepare a reference area, do the following:

1. Make certain to use a permanent land marker or temporary marker to ensure that the NRS can easily be found later in the season. You may also want to establish the location of the NRS by noting it as an A-B line or flag on the FM-1000 Plus application.

The ideal NRS would run the length of the field, but it should at least be 400 feet long.

2. At appropriate crop growth stage, take readings of the NRS and an adjacent part of the field yet to be fertilized. For most supplied algorithms the following is typical:
 - Wheat: Feekes growth stage 4-6
 - Corn: V8-V12.
3. Find the area where the nitrogen rich strip is most apparent in comparison to the rest of the field (this indicates greatest potential for the crop).

4. Take sensor readings with RT200 or Hand Held sensor for input to your selected Crop Algorithm.
5. Be sure to match nozzles and/or rate control system to maximize response time and performance for each field's requirements.

For more information, see [Field preparations for nitrogen application \(page 259\)](#) for more details, and be sure to consult your application equipment and rate control systems manuals as applicable.

Field preparations for user defined rate

The RT200 system can be used to apply other materials than nitrogen. GreenSeeker permits a custom algorithm to be entered (which is a table of product values) instead of the NDVI value. These values are entered into the *Custom Formula Application* table. See [Create a custom table \(page 423\)](#).

Note – *The grower/consultant must develop these rates. Also be aware of the rate range ability of your specific rate controller and nozzles used to achieve these results.*

Field calibration

You can use a GreenSeeker hand-held to measure the NDVI of a crop if you know the approximate desired rate for the crop.

Note – *You can also measure NDVI using the GreenSeeker RT200 by observing NDVI values on the GreenSeeker panel or by using the calibration function.*

Delivery system and liquid control

As with any variable rate system, the minimum and maximum rates obtainable are dependent upon the delivery system. The RT200 interface module is capable of "requesting" any rate, but the actual rates delivered are dependent upon the rate controller and its components. Most liquid rate control systems control or "throttle" the pressure of the system to affect flow and application rate.

When using the RT200 with a typical liquid delivery system, it is important to match nozzle sizes to expected delivery rates. After the appropriate reference strip readings, GDD, and selection of crop type are input into RT Commander, the application graph can be accessed to show the prescription rates at various sensor NDVI readings. Depending upon what delivery system is used, there will be actual minimum and maximum rates obtainable. These will be dependent upon components like the pump, control valve, nozzles, and boom plumbing sizes.

GreenSeeker has features that allow for minimum and maximum rates to be set, regardless of the crop algorithm prescription. After a nozzle set is chosen, the minimum should be set at the lowest rate the nozzles will still give adequate pattern/performance. Maximum rates may be limited by rates that lessen atomization or drift.

Select a nozzle

It is usually best to match nozzles to the lower mid-range of the typical rates shown on the application graph. Ultimately, it is up to the grower or crop consultant to determine the minimum or maximum rates and nozzles which are most appropriate.

If most of your NDVI readings (in the area of the field, not in the NRS) are around 0.53, and your review the application graph shows at 0.53 NDVI you should be applying 15GPA, then you should choose a nozzle that will have the ability to change rates above and below this NDVI reading.

You might choose a nozzle that puts out 12.5GPA at its lowest pressure (such as 20psi) and 21GPA at its highest pressure (such as 60psi). Since the penalty to under-fertilize (harm yield) is usually greater than to over-fertilize (waste fertilizer), it may be best to choose a strategy similar to the one shown here. You will need to modify your values to fit your circumstances and meet the local field and delivery system conditions.

ISOBUS setup

In this chapter:

ISOBUS settings	264
Virtual Terminal setup	264
Task Controller setup	264
GPS output settings	265
Equipment setup	266

ISOBUS is a global set of software and hardware standards that makes possible the communication between equipment made by different manufacturers.



ISOBUS settings

To set up ISOBUS features:

1. Connect the CAN bus to the FM-1000 Plus application.
2. Activate the feature/plugin you want to use. See [Optional features/plugins \(page 48\)](#).
3. If you are using Task Controller, unlock the feature.
4. Set up the feature you are using. See [Virtual Terminal setup \(page 264\)](#) or [Task Controller setup \(page 264\)](#).
5. Set up GPS speed output. See [GPS output settings \(page 265\)](#).
6. Set up the specific virtual terminal for your equipment. See [Equipment setup \(page 266\)](#).

For operational information, see [ISOBUS operation \(page 427\)](#).

Virtual Terminal setup



1. At the *Home* screen, tap .
2. At the *Configuration* screen, select  Virtual Terminal and tap **Setup**.
3. At the *Virtual Terminal Dialog* screen, select the appropriately configured CAN port on the TM-200 Module.
4. Tap **OK** to return to the *Configuration* screen.
5. Tap **OK** to return to the *Home* screen.

For operational information, see [Virtual Terminal operation \(page 428\)](#).

Task Controller setup

Make sure you have:

- Connected the CAN bus to the display
- Unlocked the ISOBUS Task Controller functionality
- Activated Task Controller

1. On the *Home* screen, tap . The *Configuration* screen displays.
2. At the *Configuration* screen, select  Task Controller and then tap **Setup**.



- At the *Task Control Setup* screen in the *Rates* tab, enter the settings.

Setting	Explanation
Target Rate 1	The first target rate for the volume supplied by the implement
Target Rate 2	The second target rate for the volume supplied by the implement
Rate Increment	When you increment/decrement Rate 1 or Rate 2 on the <i>Run</i> screen, the current application rate increases or decreases by this amount.
Minimum Rate	Minimum rate to be applied
Maximum Rate	Maximum rate to be applied

- In the *Boom* tab, enter the *Valve On Latency* and *Valve Off Latency*. These values are the measured times that it takes the implement to start coverage after the command is given.
- Tap **OK** to return to the *Configuration* screen.
- Tap **OK** to return to the *Home* screen.

For operational information, see [Task Controller operation \(page 427\)](#).



GPS output settings

- At the *Home* screen, tap . The *Configuration* screen displays.
- Select  *GPS Receiver* and then tap **Setup**.
- On the *Settings* tab, tap **GPS Output**.
- On the *CAN GPS* tab, set:
 - The *Message Rate* to 5 Hz
 - The *Output Port* to be the CAN attached to the ISOBUS for the implement
- Tap **OK** until you are back at the *Home* screen.

Equipment setup

Make sure that you have set up the Virtual Terminal and/or Task Controller before completing the rest of this procedure.

For cabling information, see XCN-2050 Cabling Guide.

1. At the *Home* screen, tap . The *Configuration* screen displays.
2. Select  Virtual Terminal then tap **Diagnostics**. The Virtual Terminal for the equipment you have connected displays.

For Kinze:

Type	Models	Set...	Virtual Terminal	Task Controller
Planter	3110, 3140, 3200, 3500, 3600, 3660, 3700, 3800	Current Ground Speed Source to GPS Speed.	x	x
		Population Option to Prescription.		x

For Kuhn:

Type	Models	Set...	Virtual Terminal	Task Controller
Seed Drill	Moduliner (HR 6004 ML)	Simulated Speed to the speed you will drive.	x	x
Spreader	AXIS-H-EMC (40.1 & 50.1)	Task Control to On.		x
		GPS Control to On.	x	x
		Set VariSpread to On.		x
		Set Change Disc Speed to On.		x
Spreader	AXIS-W (40.1 & 50.1)	Manual Speed to the speed you will drive.	x	x
		GPSC to On.		x

For Kverneland:

Type	Models	Set...	Virtual Terminal	Task Controller
Spreader	Exacta TL GEOspread	Driving Speed Signal to GPS J1939.	x	x
		Task Controller to On.		x
Drill	Accord Optima Precision Drill	Driving Speed to GPS J1939.	x	x
		Task Controller to On.		x
Drill	Monopill SE	Driving Speed Signal to GPS J1939.	x	x
		Task Controller to On.		x

For Rauch:

Type	Models	Set...	Virtual Terminal	Task Controller
Spreader	AXIS-H-EMC (40.1 & 50.1)	Task Control to On.		x
		GPS Control to On.	x	x
		VariSpread to On.		x
		Change Disc Speed to On.		x
Spreader	AXIS-W (40.1 & 50.1)	Manual Speed to the speed you will drive	x	x
		GPSC to On.		x

For Vicon:

Type	Models	Set...	Virtual Terminal	Task Controller
Spreader	RO-EDW GEOspread	Driving Speed Signal to GPS J1939.	x	x
		Task Controller to On.		x

3. Refer to the equipment manufacturer's operating instructions for how to change the settings.
4. If you are using the Task Controller, verify that the equipment recognizes it. For more information, refer to the equipment manufacturer's operating instructions .

Serial Rate Control setup

In this chapter:

Supported variable rate controllers	270
Variable rate controller setup	271
Vaderstad Control Station	277
Additional controller setup	277

By using a serial connection, serial rate control enables you to use the FM-1000 Plus application with non-Trimble variable rate controllers. A simple variable rate serial cable provides a link between your display and variable rate application controller.

Supported variable rate controllers

The FM-1000 Plus application can send control signals to vary only one channel at a time.

Variable rate controller	Supported Models
Amazone Amatron + (page 272)	Amatron+
Bogballe Calibrator (page 272)	Calibrator Zurf
Hardi 5500 and 6500 (page 273)	5500, 6500
LH Agro See LH5000 (page 274) .	LH5000
New Leader See Rawson and New Leader (page 276) .	Mark III and Mark IV
Raven (page 274)	SCS 440, 440DB, 450, 450DB, 460, 660, 661, 700, 710, 750, 760
Rawson See Rawson and New Leader (page 276) .	Accu-Plant and Accu-Rate
Tyler See Flex-Air setup (page 272) .	Flex-Air
Vaderstad Control Station (page 277)	Control Station

Variable rate controller setup

1. At the *Configuration* screen, select  Serial Rate Control and then tap **Setup**. The *Edit Variable Rate Controller settings* screen displays.
2. At the *Comm* tab, complete the settings.

Note – The fields that appear on the screen depend on which controller you selected.

Setting	Explanation
Controller	The make of the controller.
Port	The port configured and assigned to the EXP-100 that the controller is connected to.
Active Channel	If displayed, enter the channel name.
Send Rate as	Unit of measure.

3. Select the *Rates* tab and enter the settings.

Setting	Explanation
Default Rate	
Step Size	The increment for adjustment
Rate Snapping	Enabled, disabled

4. Select the *Sections* tab.
5. Enter the number of sections. Then tap **OK**.

After you have selected a type of variable rate controller, the FM-1000 Plus application initiates communications with the controller each time you open a field. Communications are terminated when you close the field.

If the FM-1000 Plus application cannot communicate with the controller:

- A message displays identifying the problem. If the controller type you chose has a configurable baud rate, the error message includes details of the baud rate that required.
- The applied rate does not display on the *Run* screen.
- Variable rate logging is suspended while the controller is disconnected.

Amazon Amatron +

1. Connect the XCN-2050 display to the Amazon Amatron + by either:
 - a. Connecting the special adapter cable (P/N 59043) to connect to the display cable (P/N 67091) that is connected to the port configured and assigned to the EXP-100.

Note – Connect the cable to the pinned connector on the lower left side of the Amatron + controller.
 - b. Connecting the display to the controller with an extension (straight through) serial cable.
2. Set up the controller:
 - a. Press **Shift + Page / Setup / Page 2**.
 - b. Set RS232 to 57600 baud.

Bogballe Calibrator

To use the Bogballe Calibrator, you need a special adapter cable (P/N 59043) to connect to the cable P/N 67091. Cable P/N 6709 will be connected to the configured and assigned EXP-100.

Note – The standoff nuts on the Bogballe rate controller may prevent the pins in the cable connector from making a connection. In this case, remove the standoff nuts.

Controller setup

To set up the controller to operate correctly with the FM-1000 Plus application, tap:

1. **Return**
2. **Return**
3. **Fertil.-Distrib**
4. **Select Type**
5. **Bogballe E/EX**
6. **Accept**

Flex-Air setup

The FM-1000 Plus application can send rates to the Tyler Flex-Air variable rate controller. The controller can have four channels

- Main
- Liquid
- Co-applicator
- Supplemental

Rates from all channels are recorded in the variable rate logging .dbf file, but the FM-1000 Plus application can send rates to only one channel at a time: the active channel.

The Tyler Flex-Air controller uses the GPS speed sent by the FM-1000 Plus application.

Operation

Statistics for the active channel are recorded in:

- The Total_Qty value in the variable rate logging .dbf file
- The Avg_Rate field in the EventHistory .dbf file

If you want to use these statistics, start a new event **before** you change the active channel.

Application width

You can individually configure the widths of the boom sections on the controller. The FM-1000 Plus application draws coverage logging at the width of the sum of all the boom sections. If you turn boom sections off, the FM-1000 Plus application varies the width of the coverage polygons according to which boom sections are on.

Hardi 5500 and 6500

1. To connect the Hardi 5500 or 6500 controller, you need a special adapter cable (P/N 59043) to connect to the cable P/N 67091. Cable P/N 6709 will be connected to the configured and assigned EXP-100.
 - a. Connect the cable to serial port 1 on the Hardi controller.
 - b. On the Hardi 6500, use terminal version 1.55 or later and Jobcom version 1.55 or later.
 - c. Set the Hardi 6500 to metric units.
2. Set up the controller:
 - a. Turn on the controller while holding the **ESC** button.
 - b. In the extended menu, use the arrow keys to select the E.4 Data Exchange menu.
 - c. Enter the COM 1 setup and complete the settings.

Setting	Enter...
Equipment type	VRA/remote
Protocol	Hardi VRA
Baud Rate	9600

3. Turn off the controller and turn it on again.
4. Go to Menu 2.3 and select VRA/Remote Control Enable.

LH5000

To use the LH 5000 controller, you need a special adapter cable (LH Agro P/N 198-701) to connect to the cable P/N 67091.

1. Connect the XCN-2050 display to the LH5000 by either:
 - a. Connecting the special adapter cable (LH Agro P/N 198-701) to connect to the display cable (P/N 67091). Cable P/N 6709 will be connected to the configured and assigned EXP-100.
 - b. Connecting the display to the controller with an extension (straight through) serial cable.
2. Set up the controller, press:
 - a. **Return**
 - b. **Return**
 - c. **Fertil.-Distrib**
 - d. **Select Type**
 - e. **LH5000**
 - f. **Accept**

Raven

To use a Raven controller with the FM-1000 Plus application, the controller must:

- Be GPS-ready
- Use Raven's latest communications protocol (which was introduced in 1996).

If your controller is not GPS-ready or does not use the latest protocol, contact Raven for an upgrade pack.

Cable P/N 6709 will be connected to the configured and assigned EXP-100. Cable P/N 6709 will be connected to the configured and assigned EXP-100.

Configure the controller

Screen or Setting Type	Settings	Additional Information
Data Menu	<ul style="list-style-type: none"> • BAUD: 9600 • GPS: Inac • DLOG: ON • TRIG: 1 • UNIT: Sec 	Some Raven controllers may lose the settings if power is disconnected. You must then reconfigure the controller.
Implement Boom Setup	<p>Application width:</p> <ul style="list-style-type: none"> • First boom section width must be greater than 0, otherwise the FM-1000 Plus application will not communicate with the controller. • Total boom section width must match the <i>Application Width</i> setting in the <i>Implement Boom Setup</i> screen. 	<p>The FM-1000 Plus application varies the width of the coverage polygons according to the number of boom sections, but it does not know the absolute width of each boom section. It only knows the relative width of each boom section with respect to the total boom section width.</p> <p>When recording coverage polygons, each section is considered to be a percentage of the application width set in the <i>Implement Boom Setup</i> screen. For example, if you create an intentional overlap to avoid gaps in the application coverage by making the application width greater than the swath width. This proportionally changes the recorded width of each boom section.</p>
Channel setting	<p>To allow rates sent by the FM-1000 Plus application to be used by the Raven controller, set channel to either:</p> <ul style="list-style-type: none"> • Rate 1 (SCS4XX, SCS6XX) • Product X Auto (SCS7XX) 	If the controller is set to Rate 2 or Manual, the controller ignores the rates being sent, but the FM-1000 Plus application still records the applied rates.
Baud Rate	9600	<p>Some older controllers are only capable of 1200 baud. Such controllers must be upgraded.</p> <hr/> <p> CAUTION – Some Raven controllers do not support zero rates. If the target rate is zero, and spray is still being applied, you must turn off the boom sections manually.</p> <hr/>

Rawson and New Leader

The Rawson and New Leader controllers use a nominal flow rate (Yield) and a step size to describe rates.

If you have a dual-channel Rawson Accu-Rate controller, see [Rawson and New Leader \(page 276\)](#).

1. At the *Edit Variable Rate Controller settings* screen, set the default rate to match the yield value (or nominal flow rate) in the Rawson controller.

Any non-zero rate will be adjusted to the nearest value that the controller can select. A rate of zero turns off the hydraulic drive.

Note – For best result when creating prescriptions, use rates in 2%, 4%, or $6\frac{2}{3}\%$ increments of the default rate. Select the percentage used on the FM-1000 Plus application.

2. Put the controller into GPS mode. This allows the FM-1000 Plus application to change the rates on the controller. (Without GPS mode, the FM-1000 Plus application will log only the rates being used.)
 - a. Turn on the controller.
 - b. Tap the **MODE** button twice.
 - c. Tap the **SET** button to switch the controller between GPS and non-GPS.
3. Set up communication between the FM-1000 Plus application and the controller:
 - a. Connect the display to the controller with Rawson cable (P/N 69730) and cable (P/N 67091).
 - b. Set the controller baud rate to 9600.

Using the controller

When in GPS mode, the hydraulic drive operates only when both the switch and the FM-1000 Plus application allow the drive to be on. Set the hydraulic drive switch on the controller to the ON position. If you need to quickly turn off the hydraulic drive, use the switch on the controller.

Non-GPS mode

The FM-1000 Plus application sends commands to the controller. If communication cannot be established, it may be because the controller is set to Non GPS mode. A message displays and gives you the option to continue in Non GPS mode.

If the controller is set to Non GPS mode, the FM-1000 Plus application still shows and records as-applied rates. If a prescription is loaded, target rates appear for reference, but these are not used by the controller. In this mode, you must vary rates manually on the controller.

Loss of communication

In GPS mode, if communication with a Rawson controller is lost, the FM-1000 Plus application does not report an error until you cross into a region of the prescription that specifies a different rate.

In Non GPS mode, the FM-1000 Plus application has no way of knowing when communication with a Rawson controller is lost.

Special note on using a Rawson Accu-Rate controller

The FM-1000 Plus application can send rates and record coverage for the Rawson Accu-Rate controller for only one drive at a time: Drive A or Drive B.

To correctly send rates to the controller and log coverage based on the drive master switch:

1. To operate both drives, set the drive that is **not** being controlled by the FM-1000 Plus application to Non GPS mode.
2. Connect the display Variable Rate cable to the COM port that matches the drive:
 - To control Drive A, connect to COM A.
 - To control Drive B, connect to COM B. When you use Drive B, set the COM port to COM B. Drive A does not have a configuration for this and will always use COM A.
3. Set Bit 7 mode to off. Bit 7 mode sends two prescriptions and is not supported by the FM-1000 Plus application.

Vaderstad Control Station

1. Connect the XCN-2050 display to the Vaderstad Control Station:
 - a. Connect the special adapter cable (P/N DCA6219) with a crossover serial cable (null modem) to the Vaderstad program cable (Vaderstad P/N 428017).
 - b. Plug the Vaderstad cable into the GPS port on the back of the Control Station controller.
2. Set up the controller:
 - a. Press the ? button and hold it down while turning on the controller.

Note – Pressing ? and selecting Info will not work if the unit is communicating with the FM-1000 Plus application.
 - b. In the *Setup* screen, scroll to GPS and then select No.

Additional controller setup

You can also set additional features on variable rate controllers, including:

- [Coverage mapping \(page 278\)](#)
- [Target and applied rates \(page 278\)](#)
- [Units \(page 278\)](#)
- [Alarms \(page 278\)](#)

Alarms

If you want low limit and target rate alarms, set these on the variable rate controller. You can also set a default rate to be used if you go off the prescription or do not have a prescription. For more information, refer to the documentation provided with your variable rate controller.

Coverage mapping

The FM-1000 Plus application receives the applied rate and can also receive the number of active boom sections from a variable rate controller. It does not receive any information about the swath or application width.

To accurately record coverage maps, if your controller does not send the number of active boom sections, set the application width to match the agricultural equipment that you are using (for example, the width of the spray boom).

Prescriptions

You can define variable rate controller setup data, and load prescription files that define the rates to be applied in different areas of the field. This information is used to send target rates to the variable rate controller. Applied rates are received from the controller, and both target and applied rates are shown on the screen. In addition, data relating to the variable rate application may be logged to the card.

The information describing prescriptions for the Field-IQ system also applies to non-Trimble variable rate controllers.

Target and applied rates

The FM-1000 Plus application can control only a single channel at any one time. This active channel is specified in the *Edit Variable Rate Controller settings* screen. The target and applied rates shown on the *Run* screen are specific to this active channel.

Units

Most controllers can be configured to use either US Imperial or metric units of measurement. Each channel can be configured to use different types of units (for example, lb/ac, oz/ac, or gal/ac.).

When constructing prescription maps, make sure that the maps use the same units that the controller is configured for.

TrueGuide setup

In this chapter:

TrueGuide system	280
Implement setup and selection	281
TrueGuide setup	282
TrueGuide calibration	283

The TrueGuide implement guidance system works with the Autopilot system.

TrueGuide employs passive implement control and uses the second GPS antenna on the implement to achieve implement location accuracy.

TrueGuide setup includes:

- Implement setup
- TrueGuide system setup
- Implement guidance calibration

TrueGuide system

The working implement behind the tractor is where precision counts, and the only way to directly influence the implement is to measure where it is and control it.

While you steer the vehicle, TrueGuide passively controls the implement to steer itself to the guidance line.

The TrueGuide™ implement guidance system:

- Is used in conjunction with the Autopilot system
- Measures the position of the implement with a second GPS receiver placed on the implement. The Autopilot system can then adjust the position of the tractor to pull the implement on the guidance line.

TrueGuide works with towed implements for front-steered, tracked, and articulated tractors.

For operation information, see [TrueGuide operation \(page 437\)](#).

Benefits

With TrueGuide, you can:

- Reduce the uncontrolled drift of the implement.
- Control large implements and minimize the effects of draft (due to varying soil conditions and ground moisture) with no additional steering hardware.
- Guide the implement to the line, even in the most difficult field patterns.
- Tow your implement online when its natural tendency is to pull through curves.
- Prevent unpredictable implement movements due to rolling terrain by adjusting on the go.
- Minimize the effect of downdraft on severe hillsides by having the Autopilot system pull the implement up the hill and hold the line.

To achieve the highest performance from TrueGuide implement guidance, the Autopilot system on the tractor must have a good calibration. An Autopilot system that is calibrated very aggressively may need to be set up with a more neutral calibration when used with TrueGuide implement guidance.

Requirements

To set up and operate, TrueGuide system must have:

- The Autopilot automated steering system installed and configured. See [Autopilot system \(page 164\)](#).

- Stable implements. (Implements that are unstable, such as sprayers with large flotation tires, will cause rocking in the antenna that will be greater than the performance improvements on the ground.)
- Both Autopilot and TrueGuide activated for use. See [Activate features/plugins for use \(page 60\)](#).
- An additional GPS receiver on the implement.

For cabling information, see XCN-2050 Cabling Guide.

For operational information, see [TrueGuide operation \(page 437\)](#).

Implement setup and selection

Before you use the FM-1000 Plus application with the TrueGuide system, set up and select a new or existing implement. See [Implement setup \(page 156\)](#).

Note – You can update existing (saved) implements with implement geometry to support TrueGuide guidance.

Note – Antenna offsets are provided when the antenna cannot be placed directly over the working point of the implement. These offsets should be minimized whenever possible.

Antenna offsets (Geometry tab)

As part of implement setup, settings on the Geometry tab are required for implement modeling. When configuring an implement for the TrueGuide system, the following antenna offsets are required:

Offset	Explanation
Hitch to ground contact point	Measured from the tractor hitch pin to the soil engagement point that the implement rotates around.
Antenna front/back	Measured from the implement working point to the center of the GPS antenna (if mounted).
Antenna left/right	Measured from the center of the implement to the center of the GPS antenna (if mounted)
Antenna height	The working height of the GPS antenna

TrueGuide setup

1. At the *Configuration* screen, select  TrueGuide and then tap **Setup**. The *TrueGuide Setup* screen displays.
2. Enter the required settings.

Setting	Explanation
Roll compensation	<ul style="list-style-type: none"> • On: Applies roll corrections from the tractor. • Off: Applies no roll corrections.
CurveGuide	<ul style="list-style-type: none"> • Off: The system does not anticipate curves. • TrueGuide only: Enables the system to anticipate curves to make corrections for TrueGuide guidance only. • Always On: Keeps CurveGuide on at all times.
TrueGuide Aggressiveness	The default aggressiveness. The recommended aggressiveness is 100%. See System aggressiveness settings .
Fixed axle to hitch point	The distance between the rear axle for conventional tractors (or the center of rotation for tracked tractors) and the draw bar.

3. Tap **OK**. The *Configuration* screen displays.

System aggressiveness settings

Aggressiveness affects the response of the implement to move to the guidance line. When aggressiveness is:

- Increased: The response to move the implement back to the guidance line is increased.
- Decreased: The response to the implement moving offline is smoothed.

1. At the *Run* screen, tap  to open the TrueGuide panel.
2. Use + or - to increase or decrease the aggressiveness.

For...	Use the default setting...
Steep slopes (10% - +30%)	150%
Slow speed operations	125%

For...	Use the default setting...
Normal operation	100%
High speed applications (> 8 mph or 12.8 kilometers per hour)	33%



TrueGuide calibration



WARNING – Many large and sudden changes in satellite geometry caused by blocked satellites can cause significant position shifts. If operating under these conditions, auto-guidance systems can react abruptly. To avoid possible personal injury or damage to property under these conditions, disable the auto-guidance system and take manual control of the vehicle until conditions have cleared.

To calibrate the TrueGuide system, you must have a field open in the *Run* screen with an AB line configured. See [Fields \(page 361\)](#) and [Guidance pattern use \(page 365\)](#).

At the *Run* screen:

1. Tap . Without closing the field, the *Configuration* screen displays.
2. Select  TrueGuide and tap **Calibrate**. The *TrueGuide Calibration* screen displays.
3. Tap **Next** and follow the on-screen instructions.
4. Complete the test at least four times and tap **OK**.
5. At the *Calibration* screen, tap **OK** to return to the open field.

TrueTracker setup

In this chapter:

TrueTracker	286
Setup process	287
Implement controller setup for TrueTracker system	287
Implement calibration for TrueTracker system	292

The TrueTracker feature/plugin works with the Autopilot system. TrueTracker uses active implement control, enabling the vehicle as well as the implement to guide to the line. This improves accuracy and product placement.

TrueTracker

The TrueTracker implement steering system is an optional upgrade for the Autopilot automated steering system. When the TrueTracker system is added to the Autopilot system, the implement receives separate guidance and steering to increase accuracy.

Implement steering actively steers the implement being towed by the vehicle. This prevents the implement from pulling to one side (called implement draft):

- On extremely sloped ground
- In variable soil conditions
- On curved guidance patterns

TrueTracker supports:

- Steering in reverse
- Straight and curved guidance patterns
- Independent implement offset
- Independent aggressiveness control for the implement
- Zero steering to center the coulters

The system has two parts:

- Additional hardware installed on the implement (which requires professional installation)
- Additional FM-1000 Plus application software provided by TrueTracker

For operation information, see [TrueTracker operation \(page 439\)](#).

Requirements

TrueTracker requires:

- An Autopilot system
- An unlock code
- AG-815 integrated radio with secondary receiver
- Second antenna
- EXP-100 port expander cable
- Platform kit for the implement actuation type
- Implement NavController and cabling

For information on TrueTracker cabling, see XCN-2050 Cabling Guide.

For operation information, see [TrueTracker operation \(page 439\)](#).

Setup process

To set up the TrueTracker system:

1. Activate TrueTracker. See [Activate features/plugins for use \(page 60\)](#).
2. Complete the implement controller settings. See [Implement controller setup for TrueTracker system \(page 287\)](#).
3. Set up the implement so that the system can tell:
 - Which type of implement is attached
 - How much area it covers
 - How far it is offset

Make sure you are measuring the offsets from the antenna to the ground interaction point of the implement. See [Implement setup \(page 156\)](#).

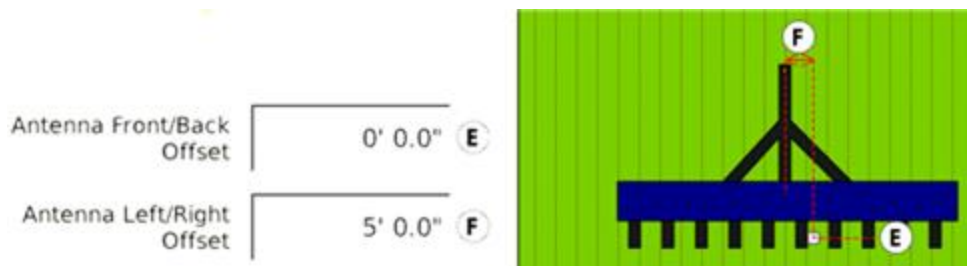



Note – When you enter the number of implement sections, if the implement does not have sections, enter 1.

4. If necessary, edit the vehicle profile. See [Vehicle settings for Autopilot system \(page 165\)](#).
5. Calibrate the implement. See [Implement calibration for TrueTracker system \(page 292\)](#).

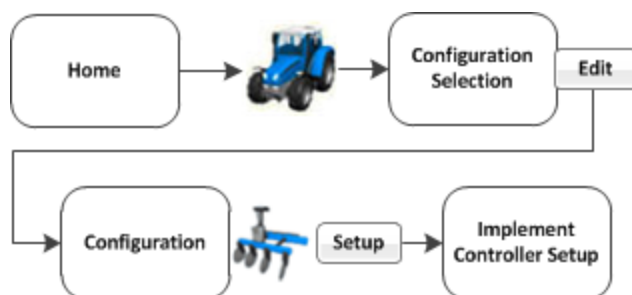
Implement controller setup for TrueTracker system



1. At the *Home* screen, tap . The *Configuration Selection* screen displays.
2. Tap **Edit** next to the implement.
3. At the *Configuration* screen, select  TrueTracker and tap **Setup**. The *Implement Controller Setup* screen displays.
4. Complete the:
 - [Vehicle settings for TrueTracker system \(page 288\)](#)
 - [Engage settings for TrueTracker system \(page 290\)](#)
 - [Steering settings for TrueTracker system \(page 291\)](#)

Vehicle settings for TrueTracker system

Note – Your vehicle make and model were selected when your TrueTracker system was installed. If your vehicle data is correct, there is no need to edit the vehicle settings. If your vehicle data is not correct, edit the implement controller.

At the *Implement Controller Setup* screen's *Vehicle* tab, complete the settings.

Setting	Explanation
Connector	TrueTracker connects to the port replicator connector on the EXP-100 and uses the secondary GPS connector of the AG-815 integrated radio. (Autopilot connects to Port A of the TM-200 Module.)
Current Selection	<p>Tap Edit if you need to change the:</p> <ul style="list-style-type: none"> • Vehicle profile • Implement model <p>When you tap Edit, the <i>Edit Implement Controller</i> screen displays.</p>

Edit vehicle profile

At the *Edit Implement Controller* screen, change the settings as appropriate.

Choose new vehicle make/model

To select a new make and model from a database of vehicles (.vdb) on the FM-1000 Plus application:

Setting	Explanation
Vehicle Profile Location	Select From Database (new).
Model	1. Tap Browse and select the required .vdb file.

Setting	Explanation
	<ol style="list-style-type: none"> 2. Tap OK. <p>After calibrating a TrueTracker implement NavController, it is recommended to save the configuration:</p> <ol style="list-style-type: none"> 1. Tap Edit and then Save Implement to file. 2. Enter the file name and tap OK. <p>Note – <i>This is the only method by which to save an implement TrueTracker NavController configuration.</i></p>

Choose existing vehicle

To select an existing vehicle from a previously saved file on the FM-1000 Plus application:

Setting	Explanation
Vehicle Profile Location	Select From Saved file (existing).
Model	<ol style="list-style-type: none"> 1. Tap Browse and select the required .vdb file. 2. Tap Open. 3. Tap Change/Restore Implement. The following message displays: The specified implement model will now be selected on the Autopilot controller. This will cause the Autopilot controller to be reset. Do you want to continue? 4. Tap OK to load the new configuration. A message displays information you the Autopilot controller will now be reinitialized. 5. Tap OK. Read the warnings and tap OK. The file is now loaded.

Change or restore implement

The **Change or Restore Implement** button is only active when you have selected either a new .vdb or a saved configuration. Until then it is not available for use.

The button is used to acknowledge and apply/load the desired .vdb or .config.

Engage settings for TrueTracker system

At the *Implement Controller Setup* screen's Engage tab, complete the settings as appropriate.

Setting	Explanation
Operator Timeout	Amount of time allowed before the operator receives an alert for lack of activity. If the operator fails to respond to the alert, the vehicle begins to drive in a tight loop.
Coverage Log	Manual: Coverage logging starts only after you tap  . When Engaged: Coverage is logged when the Autopilot system is engaged if no other system is controlling logging (such as Field-IQ or Yield Monitoring). This setting can be edited in both the vehicle and implement setup. A change in one setup location will show up in the other setup location.
Two State Engage	Off: The Engage button engages with one tap: <ul style="list-style-type: none"> • First tap: Engages implement and vehicle steering • Second tap: Disengages both implement and vehicle steering Implement First: The Engage button engages with one tap: <ul style="list-style-type: none"> • First tap: Engages the implement steering • Second tap: Engages the vehicle steering • Third tap: Disengages both implement and vehicle steering Vehicle First: The Engage button engages with one tap: <ul style="list-style-type: none"> • First tap: Engages the vehicle steering • Second tap: Engages the implement steering • Third tap: Disengages both implement and vehicle steering

Steering settings for TrueTracker system

At the *Implement Controller Setup* screen's *Steering* tab, complete the settings.

Setting	Explanation
Nudge Increment or Trim Increment	<p>Set the amount by which the Nudge or Trim buttons move the line back to the correct path, or by which the Trim buttons move the vehicle position.</p> <p>The guidance line can move off target (requiring Nudge) as a result of:</p> <ul style="list-style-type: none"> • GPS position drift when you return to the field for guidance, for example after you pause or turn off the system • GPS satellite constellation changes as you drive in the field <p>The vehicle can steer offline (requiring Trim) as a result of:</p> <ul style="list-style-type: none"> • Uneven drag on a vehicle from an unbalanced implement. • Uneven drag on a vehicle from soil conditions.
End of Row Warning	<p>Distance before the end of row warning occurs.</p> <p>Note – Longer vehicles that take longer to turn need an earlier warning and a greater distance.</p>
Autosense	On or Off
Valve on Speed	<p>For vehicles operating at speeds that are:</p> <ul style="list-style-type: none"> • Normal: Select Normal > 0.4 m/s (1.3 ft/s). Additional settings are supported only with NavController firmware versions 5.10 and later. • Slow: Select Low > 0.1 m/s (0.3 ft/s) OR Ultra low > 0.02 m/s (0.07 ft/s).

Implement calibration for TrueTracker system

The auto steering system must be calibrated for the implement you are using.

1. At the *Configuration* screen, select  TrueTracker and then tap **Calibrate**. The *Implement Controller Calibration* screen displays with a list of items to calibrate.
2. Select each item and tap **OK**.
3. Complete the calibration.

Controller orientation setup

1. At the *Implement Controller Calibration* screen, select **Controller Orientation** and tap **OK**. The *Autopilot Controller Orientation* screen displays with a graphic that represents how the controller is oriented in the cab. (If the controller is in an orthogonal orientation, a graphic of it displays. If it is not in this orientation, no graphic will be displayed.)

The graphic of the controller is shown as though:

- You are looking down on the vehicle from above.
 - The top of the screen points to the front of the vehicle.
2. Tap the buttons to select the orientation of the controller. The graphic of the controller will change as you tap the buttons.
 3. If the controller is set at a sloped angle, tap the **Direct Entry** tab. Then enter the yaw, pitch, and roll angles of the controller.

Note – If you use direct entry to enter custom angles, the on-screen image of the controller does not display.

4. Tap **OK** to accept the new orientation or tap **Cancel** to exit.

Proportional Steering Gain calibration



WARNING – The wheels can move abruptly during the Proportional Steering Gain procedure while the Autopilot system tests the hydraulic response to the steering commands. These sudden movements can cause collisions with nearby obstacles or cause injury to occupants of the vehicle. Be prepared for sudden wheel movements.

Note – Complete this calibration **only**:

- When the TrueTracker system's performance is less than acceptable
- After you complete *Implement Steering Sensor calibration* (page 294)

The proportional steering gain (PGain) setting enables you to reach a compromise between rapid steering response and stability. Modifications to the PGain setting affect two steering characteristics:

- Slew Time: The amount of time the steering coulters take to move from the far left to the far right position and from the far right to the far left position.
- Overshoot: The percentage by which the steering coulters exceed the commanded angle before they settle on the correct value.

Prior to completing this calibration:

- Complete the steering sensor calibration **before** you perform the proportional gain calibration.
- Perform the Automatic Deadzone calibration immediately before you run the PGain calibration, even if the Automatic Deadzone calibration has been performed in the past.
- Perform this calibration on a level surface, that is free of obstructions.
- Run the engine at full throttle.
- Raise the implement.

To correct slight variations caused by valve current response, friction, and hydraulic fluid viscosity, alter the PGain values:

- High PGain values: Decrease the slew time and increase the overshoot. This provides rapid responses, but can cause the steering to exhibit signs of instability (for example, a tendency to excessively overshoot).
- Low PGain values: Increase the slew time and decrease the overshoot. This improves the stability but can introduce significant delays in the steering response and can cause the vehicle to oscillate from side to side.

Increase the proportional gain up to the point just before any one of the following occurs:

- Slew times no longer decrease (a low value is required)
- Overshoot exceeds 10% (depending on the Tracker unit)
- Steering coulters noticeably shake near end stops

Calibration steps

1. At the *Implement Controller Setup* screen, select *Steering Gain* and tap **OK**. The *Autopilot Steering Gain Calibration* screen displays.
2. Tap **Next** to continue. The second *Autopilot Automated Deadzone Calibration* screen displays.
3. Tap **Next** for the next two screens that display.
4. Follow the instructions. The system will automatically move the coulters in both directions several times.



WARNING – The steering coulters can move abruptly during the Proportional Steering Gain procedure while the TrueTracker system tests the hydraulic response to the steering commands. These sudden movements can cause collisions with nearby obstacles or cause injury. Be prepared for sudden steering coulters movements.

5. Tap **Start**. The system engages and performs the calibration.
6. Tap **Run Slew Test**. A warning message displays.
7. Tap **Next**.
8. Tap **Next** in the two screens that display next.
9. Test various gain settings while you monitor the implement steering performance and the values for Slew Time and Overshoot during the Turn Left phase.
10. Adjust the New Gain value (if required).
11. Tap **Turn Left**. Both turn buttons are unavailable while the wheels slew.
Note – The optimum gain setting has short slew time (short millisecond reading) and overshoot percentage less than 10%.
12. Repeat Step 11 with **Turn Right**. Both turn buttons are unavailable while the wheels slew.
13. When you reach the best gain value, tap **OK** to save the value in the Autopilot controller memory.
14. If you want to restart the calibration procedure, tap **Cancel**.

Implement Steering Sensor calibration

Note – Complete this calibration **before** you calibrate the Automated Steering Deadzone or Antenna Roll Correction.

This calibration converts the voltage output of the steering sensor into an equivalent steering angle measurement.

Note – This calibration is only available for implements that have a steering sensor providing feedback for the steering mechanism location. Sideshift hitches do not use this calibration.

Make sure that you:

- Perform this procedure on a level surface that is free of obstructions.
- Follow the instructions on each page.
- Run the engine at full throttle.
- Raise the implement.

Calibration steps

1. At the *Implement Controller Calibration* screen, select *Implement Steering Sensor Calibration*. The *Implement Steering Sensor Calibration* screen displays.
2. For vehicles with coulters, make sure they are raised out of the ground. For other articulation methods, make sure the vehicle is slowly moving forward in a wide open space to allow free movement of the steering mechanism.
3. Tap **Start**.
4. Perform the calibration. The system will automatically steer to the right and to the left. The value for **Volts** updates as the wheels are steered.

Implement Automated Deadzone calibration

The Automated Deadzone calibration for the implement runs a series of tests on the valve and steering hydraulics to determine the point at which steering movement occurs. In this test, the system independently opens and closes each side of the steering system while determining the point at which wheel movement occurs.



WARNING – During the Implement Automatic Deadzone calibration, the system moves the wheels that steer the implement. To avoid injury, make sure that the area around the vehicle and implement is clear.

Before you begin calibration:

- Complete the [Implement Steering Sensor calibration \(page 294\)](#).
- Make sure the hydraulic fluid is at normal operating temperature when you run this procedure (to ensure optimal system performance). On some vehicles with large reservoirs, it may take several hours for the fluid to reach operating level, especially if the implement circuit is lightly loaded. Consult the vehicle documentation to determine if the hydraulic fluid temperature can be shown on a vehicle console.

If you perform the calibration while the system is still cold, repeat both the Deadzone and the Proportional gain calibration procedures after the system is at operating temperature.

Calibration steps

1. Place the vehicle in an area that is free of hazards.
2. Raise the implement.
3. At the *Implement Controller Setup* screen, select *Implement Automatic Deadzone* and tap **OK**. The *Autopilot Automated Deadzone Calibration* screen displays.
Note – Read the onscreen instructions on each page.
4. Tap **Next** to continue. The second *Autopilot Automated Deadzone Calibration* screen displays.
5. Tap **Next** in the two screens that display next.

6. Follow the instructions. The system will automatically move the coultter wheels, steering wheels or other mechanism in both directions several times.
7. Tap **Start**. The system engages and performs the calibration.

Automated Deadzone error messages

If a calibration cycle is unable to complete successfully, an error message will display.

Message: Error -	Explanation
Steering Close To End Stops	Before the calibration cycle could be completed, the measured steering angle approached the end stops. Retry, and if the problem persists, instead of centering the steering at the start of each cycle, try turning the steering in the opposite direction to that which is being tested so that the calibration procedure has a greater range to test over.
Valve Connectors Could Be Swapped	The calibration test sensed the steering turning in the opposite direction to what was expected. Retry, and if the problem persists either the valve connectors have been accidentally swapped or the steering sensor calibration was performed incorrectly.
No GPS	A GPS receiver must be connected and outputting positions before the software can run the calibration procedure.
No Steering Response Detected	During the calibration cycle, insufficient movement was sensed in order for the calibration to complete. If the problem persists, the hydraulic installation could be faulty.
Unable To Determine DZ: Try Again	A problem occurred when trying to compute dead zone. Retry, and if the problem persists, contact Technical Support.

Antenna position and roll offset correction

Before configuring the antenna compensation, make sure that:

- TrueTracker is completely set up.
- The Autopilot system is properly configured. See [Autopilot system \(page 164\)](#).
- The correct GPS corrections are enabled. See [GPS receiver settings \(page 116\)](#).

1. At the *Implement Controller Setup* screen, select Roll/Antenna Compensation and tap **OK**. The *Autopilot Roll/Antenna Compensation* screen displays.
2. Enter the appropriate settings and tap **OK**. Make sure the value entered for antenna height and distance from centerline match those entered under Implement Geometry.

Setting	Explanation
Antenna Height Above Ground	<ol style="list-style-type: none"> Place the tractor and implement on a flat, level surface. Measure the distance from the ground to the base of the GPS receiver (or antenna). Enter this value in the Antenna Height Above Ground entry box.
Antenna Distance from centerline	<ol style="list-style-type: none"> Place the tractor and implement on a flat, level surface. Measure the distance from the centerline of the implement to the center of the GPS receiver (or antenna). Enter this value into the Antenna Distance from centerline entry box and indicate whether it is left or right of the centerline. Note – Values to the left of the centerline are displayed as negative numbers. The nose of the vehicle is considered the forward direction.
Roll Offset	<ol style="list-style-type: none"> Choose the method that best matches the conditions to calculate the roll offset: Coulter wheel track offset method (page 297) or Flag offset method (page 298). Enter the average offset value in the Roll Offset entry box.
Implement Position	Select the offline direction, depending on whether the roll offset distance is to the left or right.

Coulter wheel track offset method



WARNING – The steering coulters can move abruptly during the Proportional Steering Gain procedure while the TrueTracker system tests the hydraulic response to the steering commands. These sudden movements can cause collisions with nearby obstacles or cause injury. Be prepared for sudden steering coulters movements.

1. Drive the tractor to a relatively flat field where tire impressions are visible and where you can complete passes of at least 400 m (1320 ft) in length.
2. Reset the roll offset value to 0 (zero).
3. Start a new field.
4. Create a straight AB Line.

5. Create a clean set of tire tracks in the field. To do this, start a new pass away from the area where the AB Line was created. When the system is stable, engage automatic steering mode and allow the Autopilot and TrueTracker systems to complete the pass.
6. At the end of the pass, turn the tractor around to return along the same pass from the opposite direction.
7. Engage automated steering mode and allow the system to complete the pass.
8. In the middle of the return pass, stop the tractor and confirm that the current position is directly on the AB Line. This ensures there is no cross track error.
9. Park the tractor and exit the cab. Evaluate the coultter wheel track pattern between the first and return paths.
10. Measure the difference between the track passes and record the distance. Also note whether the return pass is to the left or the right of the original pass. Record the results.

Note – The offset should be consistently to the left or right.

Test Run	Offset distance	Offset direction
1		
2		
3		
Total =		
Total / 3 (average offset value) =		

11. Repeat steps 5 through 10 two more times, for a total of three test runs. Average the results of the three runs. (Total the offset distances from the three passes and divide by three). Use the table in step 10 to record your results.

Flag offset method

1. Drive the vehicle to a relatively flat area where you can complete passes that are at least 400 m (1320 ft) in length.
2. Reset the Roll Offset value to 0 (zero) on the *Roll Correction* screen.
3. Start a new field.
4. Create a straight AB Line.

5. Start a new pass. Engage automatic steering mode when the system is stable. Stop the tractor midway through the pass. Confirm that there is no cross track error: the current vehicle position should be directly on the AB Line.
6. Park the vehicle and exit the cab. Insert a flag in the ground to mark the implement centerline for this pass.
7. Complete the pass. Turn the vehicle around to return along the same pass from the opposite direction.
8. Engage automatic steering mode. Stop the vehicle midway down the pass very close to the marker flag. Confirm that there is no cross track error. The current vehicle position should be directly on the AB Line.
9. Park the vehicle and exit the cab. Insert a second flag in the ground to mark the implement centerline for this pass. Note whether the second pass is to the left or the right of the first pass.
10. Measure the difference between the flags for the two passes and record the distance. Also record whether the return pass is to the left or the right of the original pass. Record the results.

Note – The offset should be consistently to the left or right.

Test Run	Offset distance	Offset direction
1		
2		
3		
Total =		
Total / 3 (average offset value) =		

11. Repeat steps 5 through 10 two more times, for a total of three test runs. Average the results of the three runs. (Total the offset distances from the three passes and divide by three). Use the table in step 10 to record your results.

Line Acquisition Aggressiveness calibration

1. At the *Implement Controller Setup* screen, select *Line Acquisition* and tap **OK**. The *Autopilot Line Acquisition* screen displays.
2. Adjust the line acquisition aggressiveness slider.

The slider controls how aggressively the implement approaches the guidance line, using a scale from 50% to 150%. The optimal value for each profile is not necessarily 100%. It varies for different implement profiles.

Vehicle Sync setup

In this chapter:

Vehicle Sync	302
Setup steps	302

Vehicle Sync integrates with the Field-IQ crop input control system, Tru Count clutches and the Yield Monitoring system.

Multiple users can share coverage maps, providing section control for minimized overlap and seed savings during planting season.

In conjunction with the Field-IQ system and Yield Monitoring, Vehicle Sync can influence seed placement as well as the header for increased accuracy.

Vehicle Sync

Vehicle Sync supports up to six vehicles within range of approximately 325 yards (300 m) and in direct line of sight with each other.



Requirements

For Vehicle Sync, you need:

- FM-1000 Plus application
- Vehicle Sync unlock
- [DCM-300 Modem \(page 144\)](#)
- High-gain Wi-Fi antenna kit

For operational information, see [Vehicle Sync operation \(page 442\)](#).

Setup steps

1. At the *Home* screen, tap . The *Configuration* screen displays.
2. Select  Vehicle Sync and tap **Setup**. The *Vehicle Sync Configuration* screen displays.
3. On the Setup tab, enter the appropriate settings.

Setting	Explanation
Channel	Make sure that the channel that is selected is the same on all the vehicles that you want to link. You can link up to six vehicles.
Static IP	<p>Must be unique for each vehicle being synced. If two vehicles have the same IP address, tap Generate New for one of the displays.</p> <hr/> <p> CAUTION – Do not remove power from the display or the DCM-300 modem for 10 minutes after you tap the Generate New button.</p> <hr/>
Display Name	<p>Enter a descriptive name that will be easy to recognize and select when you join the vehicles.</p> <p>Note – If you already have Office Sync, this item is populated with the vehicle name that you set up earlier.</p>

4. On the Data tab, complete the settings and tap **OK**.

When there is excessive data transfer, the FM-1000 Plus application may slow down. To help with this, it may be useful to limit the amount of data sent back and forth between displays two FM-1000 Plus application.

The Coverage and Comms Strategy settings enable you to limit the amount of data the FM-1000 Plus application sends out. For this to be effective, it is recommended that you limit the data sent out for all displays FM-1000 Plus application in the group .

Setting	Explanation
Coverage	<ul style="list-style-type: none"> • All Layers: This transfers all applied layers for the Field-IQ system. • Layer 1 only: This setting limits transfer and receiving of data to only the first product.
Comms Strategy	<ul style="list-style-type: none"> • Original: All displays always broadcast data. Every display in the workgroup is talking always and at the same time. This slows down communication traffic across the DCM and is used for heavy traffic workgroups. • Round-Round Robin: Each display takes turns communicating information to the rest of the work group. Displays talk one at a time instead of the original format.

Water Management setup

In this chapter:

Water Management features	306
FieldLevel II Survey/Design	307
FieldLevel II Leveling	310
Tandem / dual scraper setup	317
WM-Drain setup	320

Water Management functionality includes survey, design, leveling and WM-Drain functions.

Water Management features

Water Management includes:

- **Survey:** Creating surveys of areas. You use a high-accuracy GPS receiver on the water management implement to create a topographic survey of the layout of your field. The three-dimensional data shows the surface topography of the land.
Note – If you are working in a field that has already been leveled, you may not need to perform a survey and you can go straight to leveling with the FieldLevel II system or installing tile using WM-Drain.
- **Design:** After you complete the survey, you can use it to design the optimum drainage slope that can be graded with minimal dirt movement.
- **Leveling:** After you create a survey of the field and a design for how to modify it, you can use FieldLevel II to control a land-leveling implement on your vehicle and to adjust the land to an optimal slope.
- **WM-Drain:** Surface and subsurface drainage installation

Water Management system enables you to:

- Conserve precious water resources and help control the water table.
- Reduce erosion and conserve topsoil.
- Perform touch-up leveling each year.
- Use technology with a larger operating range than a laser and no vertical limit.
- Work with your existing agriculture guidance products to manage your fields with one collective system. For example, you can connect the Autopilot system to the FM-1000 Plus application at the same time as the implement.

Requirements

The Water Management system requires:

- An FM-1000 Plus application, with or without the Autopilot system
- A platform kit to suit your vehicle and valve type (P/N 55045-xx)
- An unlock code for the water management functionality
- A leveling or drainage implement

FieldLevel II Survey/Design

Benchmarks

Before you can create a survey, you must set a point at a known location called a benchmark. When you create a benchmark, the GPS receiver obtains and records location information from the base station for that specific point in your field.

When you are leveling, you use benchmarks to:

- Return to a point in the field with known coordinates to re-calibrate your exact position. This may include setting the bucket on the ground or on a solid surface that will not be disturbed while you perform field leveling.
- Move the design up or down to match the field surface at that point.

The first benchmark you create on a field is the master benchmark and displays as an orange flag labeled **MB** . Field coordinates are calculated from this point.

Subsequent benchmarks display as orange flags labeled with their corresponding number .

When you tap a button to create a benchmark, a countdown timer runs for 30 seconds and then the system creates the benchmark. To stop the averaging during the countdown, tap **Bench** again.

Rebenching

If you plan to shift the location of the base station each time you use the survey data, you can configure the system to force a re-bench. The system will not allow you to engage automatic control until the system has been re-benched.

When you are within the circle around an existing benchmark, a message displays on the *Run* screen telling you how close you are to that benchmark.

If you tap the **Rebench** button when the receiver is within the circular radius of a benchmark, the receiver is calibrated over the existing benchmark.

When you re-bench, the system automatically selects the benchmark closest to you but allows you to select the benchmark you want to use.

Settings

1. Activate FieldLevel Survey/Design for use. See [Activate features/plugins for use \(page 60\)](#).
2. At the *Configuration* screen, select  FieldLevel Survey/Design and tap **Setup**. The *Survey Setup* screen displays. Complete the settings.

Setting	Explanation
Survey Height Offset	<p>Represents the difference between the height of the blade when surveying, and the height of the blade when moving dirt.</p> <p>To measure this value, park the implement on a flat surface and raise the blade up to its highest limit and then measure the distance from the bottom of the blade to the surface of the ground. The Survey Height Offset will be applied to all surveys to avoid the need to re-bench between Survey mode and moving dirt.</p>
Survey Point Density	<p>When you create a survey of a field, this setting determines the distance between the collected survey mapping points. The approximate distances between points are:</p> <ul style="list-style-type: none"> • Coarse: 7.8 m (25 ft) • Medium: 3 m (10 ft) • Fine: 1.5 m (5 ft)
Cut/fill Color Range	<p>Defines the vertical range in which the colors are spread over the cut/fill map.</p> <p>The cut/fill map displays only after you have surveyed the field and defined a design plane. The range is displayed from the highest cut value to the highest fill value.</p> <p>For example: If your highest cut value is 1 foot and your highest fill value is 1 foot, and you set your Cut/fill color range to 2 feet, then the colors will be spread evenly across your cut/fill map. If you change the cut/fill color range to 1 foot, the colors will become more focused around the neutral area, providing more detail closer to the grade.</p>

3. Select the Relative Heights tab and complete the settings.

By default, coordinates are recorded relative to the master benchmark. Setting relative positions establishes the coordinates of the master benchmark when it is set. These coordinates are then used for field leveling and topographic mapping every time the field is opened.

Setting	Explanation
Relative Heights	Select Enabled from the list. By default, coordinates are recorded relative to the master benchmark. Setting the relative positions establishes the coordinates of the master benchmark when it is set. These coordinates are then used for field leveling and topographic mapping every time the field is opened.
Relative X	X-axis coordinate (Relative X)
Relative Y	Y-axis coordinate (Relative Y)
Height Offset	height (Height Offset)
Force Re-bench	Whether the system will force you to re-bench each time that you reload the field. Note – If you choose No, the RTK base station must be placed in exactly the same position for the field to be correct.

4. Tap **OK** to return to the *Survey Setup* screen.

Tip – To view relative offset values on the Run screen, set the offsets as status text items on the slide-out tab.

For operational information, see [Create / save a design \(page 449\)](#).

FieldLevel II Leveling

The FieldLevel II system:

- Uses a high-accuracy GPS receiver with an antenna mounted on the implement blade to measure and control its elevation
- Defines the three-dimensional height for the field and controls how the implement reshapes the ground
- Automatically raises and lowers the blade on the implement to match the design height anywhere in the field
- Includes a color cut/fill map, simple on-screen adjustments, and automatic blade control makes leveling easy
- Supports tandem or dual scraper implements
 - With a tandem system, the second scraper is also controlled by GPS. You can work in areas requiring cuts and fill two scraper buckets before you have to empty the scrapers.
 - With a dual system, an antenna on each side of the scraper controls two independent cylinders. This creates a more accurate surface by controlling the height of both ends of the scraper.
- Supports the EZ-Remote joystick or with custom switches controlled by a Signal Input Module (SIM)

Requirements

The FieldLevel II system requires:

- FM-1000 Plus application, with or without the Autopilot system
- Platform kit to suit your vehicle and valve type (P/N 55045-xx)
- Unlock code for the field leveling functionality
- Leveling or drainage implement

Setup process

Note – Before you can configure the system, it must be professionally installed. For more information, contact your local reseller.

FieldLevel II setup and calibration include:

1. [Implement settings for FieldLevel II \(page 311\)](#)
2. [GPS receiver setup \(page 311\)](#)

3. [FieldLevel II settings \(page 312\)](#)
4. [Valve module calibration \(page 316\)](#)

Leveling models



The FieldLevel II system has five leveling models:

- **Point and Slope:** The system levels at a consistent upward or downward slope, regardless of the vehicle's direction. This can be useful for installing tile and field drainage.
- **Multiplane Design:** The FieldLevel II system supports external leveling designs from Multiplane design software. This software can run a wide range of "what if" scenarios, enabling you to create complex designs with multiple field sections. You can export these design control files and then load them into the FieldLevel II system to shape the field surface based on the work in the office.
- **Plane (flat):** Use this leveling model to level a field that has previously been measured with a laser. The FieldLevel II GPS system will correct the design heights to a plane surface to match your previous laser system.
- **Plane (Earth Surface):** Use this model to level a field using the FieldLevel II GPS system. No corrections will be made to a flat plane, so the surface will be curved to match the surface of the Earth. This is the most accurate model to use so that water sits at an equal depth across a field.
- **Contour:** The system guides you around a contour and indicates whether to drive up or down to maintain your current level. This is designed for marking rice levees.

For cabling information, see XCN-2050 Cabling Guide.

For operational information, see [Leveling \(page 450\)](#).

Implement settings for FieldLevel II

1. At the *Home* screen, tap .
2. At the *Configuration* screen, tap  FieldLevel II and then tap **Diagnostics**.
3. At the *Field Level Diagnostics* screen, use the Height Control options to set the target height.
4. You can test valve functionality at any time at this screen without the need for a GPS position or an active field design open. See [FieldLevel II diagnostics valve test \(page 514\)](#).

GPS receiver setup

The FieldLevel II system uses its own GPS receiver to record the exact position of the leveling blade. To configure this receiver:

1. At the *Configuration* screen, select the  GPS Receiver that is associated with FieldLevel II and then tap **Setup**. The *WM-Drain GPS Receiver Settings* screen displays.
2. From the Receiver list, select the GPS receiver you will use for your FieldLevel system. It is recommended that you tap **Internal Primary** when configuring the display as a stand-alone FieldLevel II system, but you can use an external GPS receiver. If you are also using the Autopilot system, it is recommended that you use **Internal Secondary**, as the Autopilot system will be occupying the Internal Primary receiver.
3. From the Corrections list, select RTK for all FieldLevel II applications.
4. Set the Network ID to the same network ID that is set in the base station receiver.
5. Tap **OK**.
6. FieldLevel II is now configured and ready to use.

FieldLevel II settings

Complete the FieldLevel II settings:

- [Settings tab \(page 312\)](#)
- [Blade Settings tab \(page 314\)](#)
- [Relative Heights tab \(page 314\)](#)
- [Valve Setup tab \(page 315\)](#)
- [Height Filter Tab \(page 315\)](#)

Settings tab

1. At the *Configuration* screen, select  FieldLevel II and then tap **Setup**. The *FieldLevel II Setup* screen displays.
2. Select the Settings tab and complete the settings.

Setting	Explanation
Operation Mode	<p>Choose your leveling model.</p> <ul style="list-style-type: none"> • Point and Slope: Creates consistently sloped tile or surface drainage. • Multiplane design: Uses more complex surface designs imported from the MultiPlane design software. • Plane (Flat): Levels the field to a design plane. The plane can be configured in the on-board software using benchmarks and slopes, or by creating a plane of best-fit over a surveyed surface (Autoslope). This leveling model uses a high-accuracy GPS receiver mounted on the leveling implement. However, the design heights are corrected to a plane surface to match your old laser-leveled fields. • Plane (Earth Surface): Levels the field to a design plane. The plane can be configured in the software using benchmarks and slopes, or by creating a plane of best-fit over a surveyed surface (Autoslope). It uses a high-accuracy GPS receiver mounted on the leveling implement. • Contour: Uses the FM-1000 Plus application's on-screen lightbar to guide the vehicle along contours to keep the vehicle at the same elevation. This can be used for levee marking and applications that require guidance to elevations.
Cut/Fill Range Warning	<p>Acceptable warning distance.</p> <p>When Auto mode is engaged and the blade is outside this range for more than three seconds, a warning displays.</p>
VDOP Level	<p>Vertical Dilution of Precision: A measure of the vertical accuracy of the GPS signal. If the VDOP reaches this value, a warning message displays.</p> <p>A VDOP setting of less than 3 is recommended.</p>
Correction Age Timeout	
On Grade Tolerance	<p>Tolerance for a cut / fill value being considered on grade. The On Grade Tolerance is shown as the green color in the Cut /Fill scale. If a value of 0.5' is used for the on grade tolerance, any value between 0.5' of cut and 0.5' of fill will show as green on the Cut / Fill map.</p>

Blade Settings tab

Setting	Explanation
Blade Step	The increment that you require the blade to move each time it is stepped up or down by the plus or minus offset buttons.
Course Blade Step	Coarse mode enables you to offset the target height in large increments with a single tap, such as a 0.2' fill. The increment you want the blade to move each time it is stepped up or down in Coarse mode.
Antenna Height	Height of the antenna above the lower edge of the blade.
On-grade Limit	Distance the blade can move before the green blade height indicators change to thin red arrows. At twice this distance, the height indicators become thick red arrows. See Blade Settings tab (page 314) .
Disengage Raise	When you disable Auto while scraping a field, you can set a time value that will automatically raise the blade. For example, if you set 0.5s, the blade will raise for half a second when you turn off Auto mode.
Remote Input Auto	You can attach a remote for enabling and disabling Auto mode. This remote is controlled with the Remote Input Auto setting.

Relative Heights tab

For survey data collection or field leveling, set relative the relative offset height so that the coordinates are recorded relative to the offsets set for the master benchmark.

Setting	Explanation
Relative Heights	Enabled: For relative heights from the master benchmark Disabled: For GPS heights at all times
Relative X	The X coordinate that will be applied to the master benchmark if relative heights are enabled.
Relative Y	The Y coordinate that will be applied to the master benchmark if relative heights are enabled.
Height Offset	The height value that will be applied to the master benchmark if relative heights are enabled.
Force Re-Bench	If set to Yes and the field has been closed and opened again, the system will not let you begin work again until you have re-benched. Use this setting if you are using a different base station setup between work sessions.

Setting	Explanation
	If you have a permanent base station setup that is never moved, select No. The system will not force you to rebench.

To view relative offset values on the *Run* screen, set the offsets as status text items on the slide-out tab. See [Status items \(page 79\)](#).

Valve Setup tab

Setting	Explanation
Valve Module	Type of valve module that is detected
Valve Type	Select the type of valve that is connected.
Valve Inverted	Not Inverted: (Default) Keep this setting unless the tank and pressure hoses have been installed incorrectly on the valve. Inverted: Select if tank and pressure hoses have not been installed correctly. This eliminates the need to reverse the hoses.

Height Filter Tab

Choose the filter for height:

Setting	Explanation
None	This setting (this is the raw GPS data used for height) is recommended.
Average	The height will be averaged using the number of positions selected. This will smooth spikes in height readings but will introduce a latency into the controls.
Jump Detect	This will filter out some jumps in the height readings. When selected, the following values must be entered: <ul style="list-style-type: none"> • Threshold: The change in height value that will trigger the filter • Decay Time: After the filter is triggered, the amount of time it takes to gradually resume using the raw GPS height

Valve module calibration

Note – Depending on the make and manufacturer of your vehicle, the tractor computer may need to be put into a special mode. Refer to the *FieldLevel II Installation Guide* for your vehicle type.

1. At the *Configuration* screen, select  FieldLevel II and then tap **Calibrate**. The *FieldLevel II Calibration* screen displays.
2. Set the vehicle throttle to 100%.
3. For automatic calibration, tap **Start**.
The system performs its calibration sequence to test the speed at which the blade raises and lowers. This process takes approximately 8–10 minutes.
4. To manually calibrate the valve, enter values in the three Manual Calibration entry boxes and then tap **OK**.

Note – *Stopped DeadBand* is the control deadband that is applied when the implement is traveling at less than 0.1 mph.

Tandem / dual scraper setup

For improved productivity when leveling a field, the FieldLevel II system supports tandem or dual scraper implements.

With a tandem system, the second scraper is also controlled by GPS. This means that you can work in areas requiring cuts, and fill two scraper buckets before you have to empty the scrapers.

With a dual system, an antenna on each side of the scraper controls two independent cylinders. This creates a more accurate surface by controlling the height of both ends of the scraper.

Tandem scraper

The tandem scraper feature tows two scrapers, one behind the other. This type of leveling provides increased efficiency as it allows for the blade of each scraper to be controlled independently from the other. This means more dirt can be cut before you have to drive to a fill area and remove dirt from the scraper buckets.

For operational information, see [Tandem scraper controls \(page 463\)](#).

Dual scraper

A dual scraper is single scraper with two GPS antennas, one at each end of the blade. This allows for control of the roll of the blade, giving a more accurate surface. This configuration is ideal for complex surfaces with high variability slopes.

For operational information, see [Dual scraper controls \(page 462\)](#).

Note – For the FieldLevel II dual system you must use a scraper with dual hydraulic controls.

Set up

Note – Before you can configure the system, it must be professionally installed. For more information, contact your local reseller.

- [Implement setup \(page 318\)](#)
- [Prepare connections \(page 318\)](#)
- [Primary receiver setup \(page 318\)](#)
- [Secondary receiver setup \(page 318\)](#)
- [Tandem / Dual settings \(page 318\)](#)
- [Tandem / dual calibration \(page 319\)](#)

Implement setup

If you have not already configured the implement, see [Implement setup \(page 318\)](#).

Prepare connections

If not already installed on the FM-1000 Plus application, install:

- FieldLevel II
- Tandem/Dual

When installed, the *Configuration* screen will show:

- FieldLevel II with its associated GPS receiver
- Tandem/Dual with its associated GPS receiver

Primary receiver setup

FieldLevel II controls the primary receiver.

1. At the *Configuration* screen below Field Level, select the  GPS receiver listed and then tap **Setup**.
2. From the Receiver list, select Internal Primary.
3. From the Corrections list, select RTK.
4. Set the Network ID field to the same network ID that is set in the base receiver.

Secondary receiver setup

Tandem/Dual controls the secondary receiver.

1. At the *Configuration* screen below Tandem/Dual, select the  GPS receiver listed and then tap **Setup**.
2. From the Receiver list, select Internal Secondary.

Tandem / Dual settings

You must set up the FM-1000 Plus application to control either a tandem configuration or a dual configuration, depending upon the implement being used.

At the *Configuration* screen, select Tandem/Dual and then tap **Setup**. The *Tandem/Dual Setup* screen displays.

Setting	Explanation
Type	Tandem (Back): Default. Select to control two implements, one towed behind the other. Dual (Right): Select for a dual setup.
Antenna Height	Height of the antenna installed on either the rear implement, or the antenna installed on the right side of a single implement. Measure the antenna height vertically from the ground to the base of the antenna. Note – For FieldLevel II, the antenna height value can be altered on the Blade Settings tab and relates to the antenna installed on either the front implement, or the antenna installed on the left side of a single implement.
Disengage Raise	Used to control the rear implement or the right side of a single implement when Auto is disengaged. If you set it to 0.000s then the blade will not move up when you disengage. Note – For FieldLevel II, the disengage raise value can be altered from the Blade Settings tab and relates to the front implement's blade, or the left side of the blade on a single implement. Note – For a tandem system, move the blade up when Auto is disengaged on both the front and back implements as you will be swapping between the two. For a dual setup with a single implement, we recommend that you have the left and right Disengage Raise values set to the same value.

Tandem / dual calibration

When working with a tandem/dual configuration, the valve module must be calibrated for both:

- FieldLevel II: Relates to the front implement cylinder in a tandem configuration, or the left side cylinder of a single implement.
- Tandem/Dual: Relates to the rear implement cylinder in a tandem configuration, or the right side cylinder of a single implement.

Depending on the make and manufacturer of your vehicle, the tractor computer may need to be put into a special mode. Please refer to the *FieldLevel II Installation Guide* for your vehicle type.

1. At the *Configuration* screen, select  Tandem/Dual and then tap **Calibrate**.
2. Set the vehicle throttle to 100%.
3. Tap **Start**.
The system performs its calibration sequence to test the speed at which the blade raises and lowers. This process takes approximately 8 – 10 minutes.
4. To manually calibrate the valve, enter values in the three Manual Calibration entry boxes and then tap **OK**.

WM-Drain setup

1. If you have not completed implement setup, complete this before continuing.
 2. At the *Configuration* screen, select  WM-Survey and then tap **Setup**. The *WM-Drain Setup* screen displays.
 3. Complete the settings on each tab:
 - [Implement control settings \(page 321\)](#)
 - [Limit and increment settings \(page 323\)](#)
 - [Relative heights settings \(page 324\)](#)
 - [Valve settings \(page 323\)](#)
 - [Operation settings \(page 324\)](#)
 4. Tap **OK** when you have completed all the settings.
 5. [Calibrate the valve \(page 330\)](#).
- For operational information, see [WM-Drain operation \(page 464\)](#).

Implement control settings

Implement tab

At the Implement tab, enter the appropriate settings.

Setting	Explanation
Control Type	<p>Height Control: Select if no IMD-600 slope sensor is installed, or if an IMD-600 slope sensor is being used for roll corrections only.</p> <p>Pitch Control: Select to allow the IMD-600 slope sensor to adjust for roll and pitch corrections.</p> <p>Height and Pitch: Select to allow the IMD-600 sensor to control pitch and height.</p>
Height Gain	<p>The amount of pitch control used to get to the target height with Pitch Control Or Height and Pitch control types.</p> <ul style="list-style-type: none"> • A higher number will more aggressively pitch the plow if it is off target. • A lower number will keep the plow closer to the grade and more slowly approach the target height. <p>Default value for Pitch Control is 0.2, and for Height and Pitch is 0.0. Increase this by 0.05 increments and fine tune if the plow is not pitching enough to achieve the target depth.</p>
Antenna Height	The distance from the antenna to the bottom of the boot.
Antenna Selection	Select the appropriate antenna from the list.
Survey Height Offset	The distance from the tip of the boot to the ground when the plow is in the survey position (height and pitch cylinders both in full up position).
Survey Point Density	The distance between the collected survey mapping points.
Slope Sensor (IMD-600)	<p>Select the serial number of the installed IMD-600 slope sensor that is used for pitch and roll corrections. It is recommended that the IMD-600 be installed parallel to the bottom of the boot. See XCN-2050 Cabling Guide.</p> <p>IMD-600 is a CAN device and must connect to Port A of the TM-200 Module.</p> <p>Click Measurements to open the Tile Plow Measurements screen and select the appropriate settings.</p>
Slope Transition Distance	Distance required to transition the plow to a different slope

Setting	Explanation
	<p>increment. If you are using the Pitch Control OR Height and Pitch control type, it is recommended to set this measurement to twice the length of the boot.</p> <p>If you are on a particularly rough ground, you can increase this distance to three or four times the boot length for smoother operation of the pitch cylinder. If you want the plow to follow the ground contours more closely, reduce this distance to the boot length.</p>

Tile Plow Measurements

At the *Tile Plow Measurements* screen (when you are setting up Pitch Control and Height and Pitch control types), complete the settings and tap **OK**.

IMD-600 section

Setting	Explanation
Label Faces	The direction (Up, Down, Left, Right) that the IMD-600 label faces in relation to the direction the plow travels during installation.
Connector Faces	The direction (Left, Right, Forward, Back) that the IMD-600 connector faces in relation to the direction the plow travels during installation.
Pitch Offset	<p>The amount of angle or tilt (up or down) if the sensor is not installed parallel to the bottom of the boot.</p> <p>If you adjust the pitch offset, this can help correct the boot pitch if it is not running level through the ground.</p>
Roll Correction	Corrects for static roll caused by minor variations in the sensor mounting.

Antenna section

Setting	Explanation
Horizontal	The distance from the leading edge of the boot to the center line of the antenna. The horizontal distance should be positive if the antenna is forward from the tip of the boot and negative if it is backward.
Vertical	The distance from the bottom of the boot to the base of the antenna dome.

Setting	Explanation
Lateral	Offset of the antenna from the center line of the pipe.
Boot Length	Distance from where the pipe exits, to the back of the boot, to the leading edge of the boot.
Offset	The distance of the GNSS antenna from the approximate center of vehicle rotation (the fixed rear axle of a towed plow or the center of the tracks). Forward is the antenna in front of the pivot point. Backward is the antenna behind the pivot point.
Antenna Selection	Select the antenna from the list.

Valve settings

Select the **Valve Setup** tab and complete the settings for the PWM valve.

Setting	Explanation
Valve Module	Displays the type of valve module that is detected.
Valve Type	Select the type of valve that is connected.
Valve Inverted	Leave this value as Not Inverted unless the raise and lower hoses have been installed incorrectly on the valve. If this is the case, select Inverted to eliminate the need to reverse the hoses.

Limit and increment settings

Select the **Steps** tab and complete the settings.

Setting	Explanation
Height Step	Fine: You can change height steps in small increments. Coarse: You can change height steps in large increments.
Pitch Step	Fine: You can change height steps in small increments. Coarse: You can change height steps in large increments.
On-grade Limit	This limit sets the distance the blade can move before the green blade height indicators change to a thin red arrow. At twice this distance, the height indicators become thick red arrows. See blade position in Blade level indicators (page 452) .
Slope Adjust	This percentage controls the amount the gradient changes

Setting	Explanation
	<p>each time you increase or decrease the slope on the <i>Install</i> tab when in <i>Point and Slope</i> mode.</p> <p>For example, if the leveling gradient is 3% and the <i>Slope Adjust</i> value is set to 2%, the leveling gradient changes to 5% if you decrease the slope.</p>

Relative heights settings

Select the *Relative Heights* tab and complete the settings.

Setting	Explanation
Relative Heights	<p>Enabled: Select to use the relative heights from the master benchmark.</p> <p>Disabled: Select to use GPS heights at all times.</p>
Relative X	If relative heights are enabled, this is the X coordinate that will be applied to the master benchmark.
Relative Y	If relative heights are enabled, this is the Y coordinate that will be applied to the master benchmark.
Height Offset	If relative heights are enabled, this is the height value that will be applied to the master benchmark.

Operation settings

Select the *Operation* tab and enter the settings.

Setting	Explanation
Force Rebench	<p>Yes: If the field has been closed and then reopened, the system will not allow you to begin work until you have re-benched. Use this setting if you are using a different base station setup between work sessions.</p> <p>No: Select if you have a permanent base station setup that is never moved.</p>
VDOP Level	Vertical Dilution of Precision measures the vertical accuracy of the GPS signal. If the VDOP reaches the value you enter, a warning will display. A setting of less than 3 is recommended.
As-Built Logging	Manual: Logs data if hydraulics are engaged and if you have begun logging in the <i>Run</i> screen.

Setting	Explanation
	Engage: Logs data only if Auto is engaged on the plow.
Filter Type	<p>None: Raw GPS data is used for height. This setting is recommended.</p> <p>Average: The height will be averaged using the number of positions selected. This will smooth spikes in height readings but will introduce a latency into the controls.</p> <p>Jump detect: This will filter out some jumps in the height readings. When you select this, you must enter the following values:</p> <ul style="list-style-type: none"> • Threshold: The change in height value that will trigger the value. • Decay Time: When this filter is triggered, this will be the amount of time it takes to gradually resume using the raw GPS height.

Calibrate WM-Drain for cantilever plow

Follow the steps in sequence for consistent calibration results and improved performance. If you skip steps, you may experience inconsistent results.

Step 1: Select the mode

1. At the *Configuration* screen, select  WM-Drain and then tap **Setup**. The *WM-Drain Setup* screen displays.
2. On the *Implement* tab, from the *Control Type* list select **Pitch Control**.
3. Tap **Measurements**. The *Tile Plow Measurements* screen displays.
4. Enter all measurements as accurately as possible to the nearest 0.25 inch (1 cm).
5. Tap **OK** to return to the *WM-Drain Setup* screen.
6. On the *Implement* tab, enter values for **Height Gain** and **Slope Transition**.
7. Calibrate the roll offset.

Step 2: Set up the system

In the *Implement* tab, enter the values for **Height Gain** and **Slope Transition Distance**. See [Implement control settings \(page 321\)](#).

Step 3: Calibrate Roll Offset

1. At the *Configuration* screen, select  WM-Drain and then tap **Diagnostics**. The *Drainage Diagnostics* screen displays.
2. Complete the roll offset calibration using one of two methods.

Method 1

1. Park the system on a known level surface. Ensure the boot is flat on the ground.
2. Note the **Roll** value on the *Drainage Diagnostics* screen.
3. At the *Tile Measurements* screen, for the **Roll Correction** value enter an offsetting value.

For example:

- Current angle reading = $.07^{\circ}$
 - IMD-600 Roll reading = -0.2°
 - Roll Offset = 0.9°
4. Return to the *Drainage Diagnostics* screen. Wait approximately 30 seconds for the filtered

reading to settle on a stable value.

- If the Roll value is $\pm 0-0.1^\circ$, the roll offset calculation has been calibrated correctly.
- If the Roll value is not $\pm 0-0.1^\circ$, note the value and then repeat Step 3 to enter a value that corrects for any remaining error.

For example:

- Current angle reading = $.07^\circ$
- IMD-600 Roll reading = 0.5°
- Increase Roll Offset by 0.2° . Roll Offset now = 1.1°

Method 2

1. Park the system on a known level surface. Ensure the boot is flat on the ground.
2. Place a digital angle indication device flat against a smooth surface on the side of the system's boot shank. Note the roll angle of the boot shank.
3. Note the Roll value that displays on the *Drainage Diagnostics* screen.
4. At the *Tile Measurements* screen, for the Roll Correction value enter an offsetting value.

For example:

- Shank angle reading = 4.7°
 - IMD-600 Roll reading = 2.5°
 - Roll Offset = -2.2°
5. Return to the *Drainage Diagnostics* screen. Wait approximately 30 seconds for the filtered reading to settle on a stable value.
 - If the Roll value is $\pm 0-0.1^\circ$ of the measurement taken in Step 2, the roll offset calculation has been calibrated correctly.
 - If the Roll value is not $\pm 0-0.1^\circ$, note the value and then repeat Step 2 to enter a value that corrects for any remaining error.

For example:

- Shank angle reading = 4.7°
- IMD-600 Roll reading = 4.5°
- Increase Roll Offset by -0.2° . Roll Offset now = -2.4°

Step 4: Calibrate the valve

Perform an automated valve calibration to provide the best valve drive performance. See [Valve module calibration \(page 316\)](#).

Step 5: Tune system performance

The system gains may need to be fine tuned to reach the desired level of system performance.

1. Set the tractor hydraulics to ~70% of the maximum flow. This will allow you to fine tune the hydraulics without adjusting any other calibration settings.
2. Walk beside the system while operating a dry run. This allows you to see the visual cues necessary for efficient gain adjustment. Pay close attention to the cylinder movement and note any directional trend.

Excess movement in both directions can indicate the following:

- Hydraulic flow is too high. It is recommended that you drop the flow by 5% and then recheck.
- Drop both valve gains by 5% and then check for improved performance.

Excess movement in one direction can indicate:

- Valve gain in that direction (raise or lower) is too high. Drop the corresponding valve gain by 5% and then check for improved performance.
- Valve gain in the opposite direction (raise or lower) is too low. Raise the corresponding valve gain by 5% and then check for improved performance.

Step 6: Set the height gain

Fine tuning the height gain and the overall valve gains are a crucial step in perfecting the precision control of a cantilever plow with the WM-Drain system.

In the Implement tab, adjust the Height Gain values:

1. Manually drive the plow to a depth below the optimal depth of the section line that you have surveyed and designed for this calibration run. The system will default to a Height Gain of 0.2.
2. Move forward at the speed and RPM that you will be running the plow. When the vehicle is moving, engage the WM-Drain system and note how quickly the system takes to get to the design depth.

Note – *The system may not go the optimal depth that you have entered at this time because the pitch offset of this plow has not been determined. In this test, the system should drive to a consistent depth each time it is engaged.*

3. If the system is too lazy/slow to get to depth within a reasonable distance, increase the height gain setting by a value of 0.05. Continue to raise this value until the plow achieves depth at the required speed.

Note – *The plow may oscillate while on grade.*

4. Split the last two values you entered.

For example:

- Height Gain run prior = 0.300
- Height Gain current run = 0.350
- Height Gain to try next run = 0.325

Note – After you have determined the optimal values for a particular plow series, such as Liebrecht 5' plow, it is very likely that you can enter the same measurements, offsets, and height gain values for other plows of the same series. With a good valve calibration for each plow, you should be able to get each subsequent plow running very quickly.

Determine the pitch offset

Note – It may take some time to determine the proper pitch offset of a plow accurately.

Without a correct pitch offset, the system will most likely attempt to maintain the design slope and drive the plow above or below the optimal depth.

All cantilever plows must assume an angle that is slightly tipped up in order to maintain depth against the immense down-pressure being applied by the soil that is being displaced. If the boot traveled through the soil with an even attitude the plow would progressively plow deeper as it was pulled through the soil.

After the pitch offset value has been determined, the value should only change as the tip begins to show considerable wear.



Note – Before completing this process, ensure that the system drives to a consistent depth. This depth may not be the optimal depth, but it will ensure that the hydraulic system is operating well. Once you are certain that optimal performance has been achieved, you may begin the process of determining the proper pitch offset with consistent results.

1. Engage the plow on a newly surveyed section line in soil that has been undisturbed.
 2. Allow the system to drive the vehicle to a consistent depth and then begin entering a positive Pitch Offset value in the Implement tab. Enter values in 0.50% increments.
- Note** – It may take 1-2 lengths of the boot for the system to fully recognize this offset.
3. Continue the actions in Step 2 until you are within a few hundredths of optimal depth.
 4. Allow the system to drive along the entire section line. Ensure that the system continues to be consistent through any transitions that are found in the current section line.
 5. When you believe the system is running with the highest accuracy possible, survey another new section line. Allow the system to drive the entire line.
 6. Repeat Step 2 through Step 4 until the system gives a consistent result. Note the pitch offset value you came up with and reset the run screen offset back to 0.00%.
 7. At the *Measurements* screen, enter the determined Pitch Offset value.

Note – Once determined, this value should only change once the tip begins to show signs of considerable wear

Calibrate the valve

WM-Drain performs its calibration sequence to test the speed at which the blade raises and lowers. This process takes approximately 8 - 10 minutes for each valve.

1. At the *Home* screen, tap . The *Configuration* screen displays.
2. Select  WM-Drain and tap **Calibrate**.
3. Select the appropriate valve (depth or pitch), if applicable.
4. At the *Depth Valve Calibration* screen, set the vehicle throttle to 100% and tap **Start**.
Note – To manually calibrate the valve, enter values for manual calibration and tap **OK**.
5. When the procedure is complete, tap **OK**.
6. Repeat this procedure for another valve, if applicable.

Note – To stop the plow cylinders from working excessively when stopped, you can add a value for *Stopped Deadband*.

Yield Monitoring setup

In this chapter:

Yield Monitoring functionality	332
Yield Monitoring best practices	333
Yield Monitoring settings	336
Yield sensor / moisture sensor calibration	340
Third-party display instructions	343

Yield Monitoring obtains data from mass, flow, and moisture sensors to gather data and define high and low productivity areas of a field during harvest.

Yield Monitoring functionality

The Yield Monitoring module collects data from .from OEM or Trimble installed yield monitoring sensors, and sends that data to the FM-1000 Plus application.

Yield Monitoring enables you to accurately view, map, and record crop yield and moisture data in real-time during harvest to immediately understand how well your crop performed.

Supported yield monitoring types range from EOM sensors (both CAN and Serial) to Trimble's full Yield Monitoring CAN solution.

Yield Monitoring functions include:

- [Variety tracking \(page 483\)](#): Map and compare the performance of different seed varieties throughout your field.
- **Moisture tracking**: Determine if grain needs to be stored or dried based on the in-field moisture content.
- [Load tracking \(page 484\)](#): Record the amount of grain harvested and loaded onto your trucks.
- **Auto-cut width adjustment**: Adjust the cut width automatically when traveling over odd-shaped fields, point rows, or other previously harvested areas to improve the accuracy of yield calculations.

Yield Monitoring best practices

There are key practices required to use the Yield Monitoring system to best advantage. Read this before you start the installation and setup procedures.

Installation

The Yield Monitoring System relies on an appropriate installation of the optical sensors. To ensure the best results:

- Install the optical sensors in the location described in the *Installation Guide*.
- If the desired location is not achievable, install the optical sensors as high as possible, but no more than 6 inches (15 cm) below the top spindle of the elevator.
- Installing the sensors lower than 36 inches (90 cm) above the bottom spindle will give unacceptable results.
- Interference: Ensure that there is no opportunity for interference between the optical sensors or the retaining brackets and any moving parts on the combine. Be especially aware of chains, belts, pulleys, and tensioning rods, and keep in mind that their range of motion may be much greater during operation than when standing still.
- Alignment: Ensure that the optical sensors will not move out of alignment during operation.
- Paddle support bracket: Ensure that the optical sensors will not sense the paddle support bracket. Refer to the *Installation Guide* for more information.

Tare calibration

The quality of the Tare Calibration is critical to getting good accuracy, particularly at low flow rates. To ensure the best results:

- Check the tare daily.
- When performing the tare calibration, run the system at the same speed as you would normally use during operation.
- While running the system empty, look at the elevator speed. This number must be correct, typically between 12–20 Hz.
- Run the tare calibration. The tare value represents the measured thickness of the paddles, and should be approximately correct. It is more important that the number is consistent than that is exactly right.
- If the measured value is considerably higher than expected, check the entered values for paddle spacing, and check that the optical sensors are not being obscured by the support brackets on the paddles.

- If the measured value is considerably lower than expected, recheck the entered paddle spacing and the elevator speed. If both are correct, low tare should not be a problem.
- Tare Deviation indicates how much variation there is in the measurement of the paddle size. Normally, this number should be less than $\frac{1}{4}$ the size of the paddle itself. If this number is excessively large, check the installation for interference or opportunities for excessive vibration, like a poorly-tensioned elevator chain.

Flow calibration

Calibrating the Yield Monitoring system across the full range of flows will improve the accuracy of the system. To get a good calibration, do the following:

- Select calibration loads where the:
 - Conditions are consistent
 - Crop quality is even
 - Ground is as level as possible
 - The passes are as long as possible.

Keep the combine speed constant during the entire run.

- Collect loads that are as large as is practical without sacrificing consistency.
- Collect as many different calibration loads as possible, with each load at a different flow rate. To accomplish this, you can run the system at different speeds, or harvest partial header widths.
- If you still have significant errors in the calibrations, check the noise level during harvesting. If this figure is above 30%, check for interference with the optical sensors, or opportunities for excessive vibration. If your paddles are very worn, they may need to be replaced.

Pitch/Roll calibration

The Yield Monitoring system corrects for the pitch and roll of the combine. To benefit from this feature, perform the pitch/roll calibration as described in the owner's manual.

The system has correction parameters for each tilt direction that you can adjust to improve performance. Use the following table when you decide how to adjust these parameters.

Note – The pitch sensitivity adjustment depends on whether your sensor is mounted in front of or behind the center of the paddle.

Tilt angle	Yield reading too high	Yield reading too low
Left roll	Increase left roll sensitivity	Decrease left roll sensitivity
Right roll	Increase right roll sensitivity	Decrease right roll sensitivity
Backward pitch, sensor	Decrease backward pitch	Increase backward pitch

Tilt angle	Yield reading too high	Yield reading too low
forward of center	sensitivity	sensitivity
Backward pitch, sensor aft of center	Increase backward pitch sensitivity	Decrease backward pitch sensitivity
Forward pitch, sensor forward of center	Increase forward pitch sensitivity	Decrease forward pitch sensitivity
Forward pitch, sensor aft of center	Decrease forward pitch sensitivity	Increase forward pitch sensitivity

To start, adjust the sensitivity numbers in increments of 0.2.

Test weight

The Yield Monitoring system measures the volume of grain passing through the combine, and estimates the weight by multiplying the measured volume by the test weight. Therefore, an accurate measurement of test weight is required in order to achieve an accurate total weight measurement. To ensure the best results:

- Recheck the test weight whenever the field conditions change significantly, either when harvesting different varieties, or when the moisture level of the crop changes.
- Take several samples of test weight on calibration loads, and use the average of these samples when calibrating.

Calibrating and operating conditions

How you operate your combine can affect your accuracy. Consider the following:

- Calibration will be most effective if you operate your combine at the same conditions as you used during calibration.
- Frequent starts and stops during a load could degrade the overall accuracy of the load.

Yield Monitoring settings

The following yield monitoring systems are supported:

- Trimble Yield Monitoring
- Various supported OEM moisture sensors
- Claas, 670 and 700 series (**North America only**)
- John Deere, -60 and -70 series
- Serial data input

Note – *The Serial tab is not available when you are setting up a Trimble Yield Monitoring, Claas, or John Deere module.*

Before setup

Before setting up Yield Monitoring, make sure:

1. All components are installed on the vehicle. Refer to the *Installation Guide* that is shipped with every Yield Monitoring kit.
2. Yield Monitoring has been added to the display's configuration. See .
3. The implement has been set up and configured for the appropriate operation. See [Implement setup \(page 156\)](#).

Setup steps

To complete the setup for Yield Monitoring:

1. Choose the combine and complete its settings. See [Combine settings \(page 336\)](#).
2. Complete the [Operation settings \(page 337\)](#).
3. Enter the [Crop settings \(page 338\)](#) for your crop.
4. Complete settings for the map legend. See [Map settings \(page 339\)](#).
5. Complete the [Sensor output settings \(page 339\)](#).
6. Complete the [Options settings \(page 339\)](#).

Combine settings

At the *Yield Monitoring Setup* screen on the Setup tab, enter information about the harvester you are using.

Setting	Explanation
Combine	Make of harvester
Series	Series of combine
Yield Monitor Type	Type of Yield Monitoring: <ul style="list-style-type: none"> Trimble YM (Yield Monitoring): If this option is selected, connect the Yield Monitoring system to any available CAN port on the TM-200 module or the configured and available EXP-100. Serial data input
Port Connection	Choose the EXP-100 configured and assigned for serial communication. If Yield Monitor Type is not set to Serial, the Port Connection does not display.
Moisture Sensor	Moisture sensor you are using: <ul style="list-style-type: none"> Trimble Case IH New Holland AGCO Ag Leader
Advanced Setup	

Operation settings

At the *Yield Monitoring Setup* screen on the Operation tab, enter information about the combine you are using.

Note – The selections available on the Operation tab may vary depending on the yield monitoring type that you selected.

Setting	Explanation
Header Height Sensor	Enabled: The sensor is enabled. Disabled: The sensor is disabled.
Head Logging Height Note – Not available for the Claas 600/700. This is set by the CEBIS.	The height at which yield data logging starts and stops. The Head Logging Height is read from the Header Height Sensor. If required, tap Current Height to enter values related to your own setup.
Grain Flow Delay	Time (in seconds) it takes for the grain to reach the yield sensor after it enters the head

Setting	Explanation
Reset Autocut	<p>Controls when the rows are automatically reset</p> <ul style="list-style-type: none"> • When head is lifted: Automatically resets the rows at the end of the row when the head is raised above the logging height • Never: Disables autocut. Rows must be controlled manually.
Crop Overlap	<p>When more than one crop variety is detected in the head, the system will stop accumulating variety statistics. Use this setting to adjust the percentage of crop overlap that is allowed before the system stops accumulating variety statistics.</p> <p>Select a value between 1% and 25%. For best results, the recommended setting is 10%.</p>

Crop settings

At the *Yield Monitoring Setup* screen on the *Crop* tab, enter the settings for your crop.

Setting	Explanation
Commodity	Select the crop that is currently being harvested
Units	<p>Select the unit of measure for the crop type:</p> <ul style="list-style-type: none"> • Bushels/acre • Lbs/acre • Tons/acre • Hundred Weight/acre (When this is selected, the Bushel Weight field is automatically set to 100 lbs.) • Bushels/hectare • Kgs/hectare • Tonnes/hectare
Standard Bushel Weight	Enter the weight of a single bushel of crop.
Storage Moisture	Set the cutoff point between a wet crop and a dry crop. Set these values depending on what you want the map to look like.
Moisture Upper Limit	Range from 5-40%. The working limit of the sensor if a trimble moisture sensor is attached.

Map settings

At the *Yield Monitoring Setup* screen on the Map Legend tab, enter information about the yield and moisture values to display on the *Run* screen.

Setting	Explanation
High Yield	Highest expected yield for the current event
Low Yield	Lowest expected yield for the current event
High Moisture	Highest expected moisture for the current event
Low Moisture	Lowest expected moisture for the current event

Sensor output settings

At the *Yield Monitoring Setup* screen on the Serial tab, enter what output you want from the sensors.

Setting	Explanation
Baud Rate	Modulation rate of data transmission in seconds
Parity	<ul style="list-style-type: none"> • None: No parity bit sent • O: Odd parity bit • Even: Even parity bit • Mark: Parity bit is set to mark signal condition • Space: Parity bit is set to space signal condition
Data Bits	Number of data bits to transmit
Stop Bits	Number of bits that represent the stop message. Used to identify the end of the cropping message when transmitted by the system.

Options settings

At the *Yield Monitoring Setup* screen on the Options tab, select the setting for New/End Load Confirmation.

Yield sensor / moisture sensor calibration

To calibrate the yield sensor and moisture sensor, use either of these:

- Single-Load Calibration
- Multi-Load Calibration

Before starting either procedure, keep the following in mind:

- Use the same load type for both yield and moisture calibration.
- To achieve the highest accuracy, perform the Multi-Load Calibration procedure.

Calibration steps

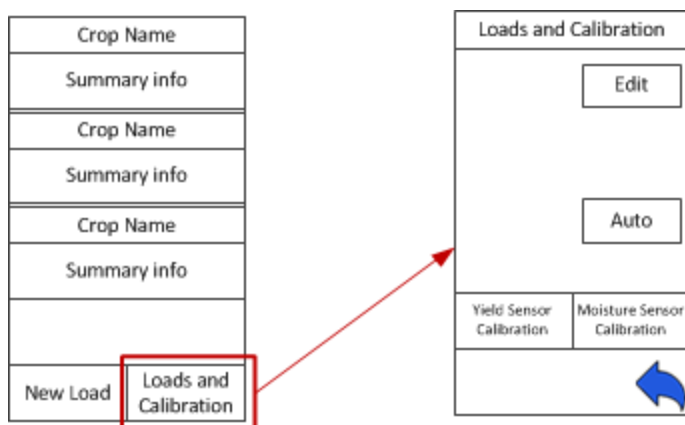

1. Verify that all Yield Monitoring setup parameters are correct.
2. At the *Run* screen, tap  to open the Yield Monitoring panel.
3. Tap **Loads and Calibration**. The Loads and Calibration view of the panel displays.
4. Tap either **Yield Sensor Calibration** or **Moisture Sensor Calibration**, depending on which calibration you want to perform.
5. Calibrate the Header Height.
6. Calibrate the Temperature.
7. Calibrate the Roll Offset.
8. Calibrate the Yield Sensor Tare.

If the Average Tare Deviation is equivalent to or greater than the thickness of the elevator paddle, the system may encounter a large amount of noise. “Noise” can be introduced into the system by any of the following factors:

- Paddles contacting the Yield Sensor optical lens
 - Yield Sensor optical lens obstructed
 - Yield Sensor(s) loose
 - Elevator chain with excessive slack or paddles flopping up/down
 - Tensioning rod contacting yield sensors
 - Excessive paddle wear causing large quantities of grain to fall back down the elevator between the elevator wall and the outside of the paddles
9. To check the noise percentage of the system, turn the combine separator on at full engine RPM and then select Yield Monitoring / Diagnostics / Status to see the noise percentage. If this is very high, check the aspects listed.
- Note** – *If the frequency deviation is high, you may have an inconsistent Elevator RPM and may need to inspect the performance of your clean grain elevator pulleys, bearings, chain, and so on.*
10. Select either method for calibration:
- **Speed method**: Uses a consistent speed variable to calibrate for Low, Medium, and High flows.
 - **Cut Width method**: Uses a consistent cut width variable to calibrate for Low, Medium, and High flows.

Speed method

1. Conduct a calibration load of 3,000-6,000 lbs. at your normal constant speed.
2. Repeat this procedure for:
 - One load at 1 mph less than the normal operating speed
 - One load at 2 mph less than the normal operating speed
 - One load at 1 mph higher than the normal operating speed

This provides a calibration curve for Low, Medium, and High flow variations throughout the course of harvest.

An example of calibration loads using this method is as follows:

- Load 1 = 4,547 lbs. @ 4 mph
- Load 2 = 3,834 lbs. @ 3 mph
- Load 3 = 2,764 lbs. @ 2mph
- Load 4 = 5,768 lbs. @ 5 mph

Cut width method

Note – It is highly recommended that you conduct a minimum of three calibration loads to ensure that the system provides accurate readings for all low, medium, and high flows throughout harvest. If you conduct a Single Load calibration, this may result in poor accuracy performance when Harvesting outside the Flow range at which the system was initially calibrated.

1. Conduct a calibration load of 3,000-6,000 lbs. at your normal constant speed with a 100% cut width (12 rows at 30 ft).
2. Repeat this procedure for:
 - One load at 75% of the normal cut width (8 rows at 20 ft)
 - One load at 50% of normal cut width (6 rows at 15 ft)
 - One load at 25% of normal cut width (3 rows at 7.5 ft) at the same constant speed

This provides a calibration curve for Low, Medium, and High.

Flows vary throughout the course of Harvest.

An example of calibration loads using this method is as follows:



- Load 1 = 5,768 lbs. @ 4 mph @ 100%
 - Load 2 = 4,547 lbs. @ 4 mph @ 75%
 - Load 3 = 3,834 lbs. @ 4 mph @ 50%
 - Load 4 = 2,764 lbs. @ 4 mph @ 25%
3. At the *Yield Sensor Calibration* screen for each load:
 - a. Enter the actual scale weight.
 - b. Enter the actual test weight (average of a minimum of three test weight measurements).
 - c. Select each load for which the actual weight and test weight will be calibrated.
 - d. Tap **Update Calibration**.
 - e. Tap **Apply Calibration**.
 4. At the *Moisture Sensor Calibration* screen for each load:
 - a. Enter the actual moisture.
 - b. Select each load for which the actual moisture will be calibrated.
 5. Tap **Update Calibration**.
 6. Tap **Apply Calibration**.

Third-party display instructions



Claas Cebis Quantimeter setup

Note – When using Yield Monitoring with Claas Quantimeter, always set Autopilot Coverage Logging to manual. See [Engage settings for Autopilot system \(page 165\)](#).

Crop Harvested setting

1. On the Cebis display, tap  and then tap .
2. Tap  and then select the crop that you are harvesting.

Moisture Measuring setting

1. Tap  and then tap .
2. Tap  and then adjust the following settings:
 - Status
 - Moisture correction
 - Display of yield with storage moisture
 - Adjust storage moisture
 - Display of current moisture

Bulk Density setting

1. Turn the HOTKEY dial to the scales icon.







2. Adjust the crop density by rotating the HOTKEY until the correct value displays on the screen.







Note – The lbs/bu value must be set before the Weight Measured function can be used.









Zero Yield setting

1. Tap  and then tap .
2. Tap  and then tap .
3. Tap **OK**.

Zero Angle setting



1. Tap  and then tap .
2. Tap  and then tap .
3. Tap **OK**.

Claas Cebis Quantimeter calibration





1. Tap  and then tap .
2. Tap  and then scroll to **On**.
3. Harvest a full grain tank or truck load.
4. After the tank or truck is full, tap  and then tap .
5. Tap  and then scroll to **Off**.
6. Weigh the grain tank or truck to get a scale ticket.
7. Tap  and then tap .
8. Tap  and then tap Crop yield weighted.
9. Scroll to increase or decrease the value until it matches the weight on the scale ticket.

Claas Cebis Auto Pilot calibration



Activate the AutoPilot system

1. Tap  and then tap .
2. Tap  and then scroll to On.



Steering angle and steering system setup

1. Tap  and then tap .
2. Tap  and then tap .
3. Tap Learning sensing system.





Centralizing switch setup

1. Tap  and then tap .
2. Tap , scroll left or right to adjust the central position and then select **OK**.

Steering sensitivity setup

1. Tap  and then tap .
2. Tap , scroll left or right to adjust the steering sensitivity and then select **OK**.

Greenstar Monitor: Stop Head Height setup

1. Tap .
2. Tap   for Harvest Monitor.
3. Position the header to 100%.
4. Tap   next to Record Stop Height.

Stop Head Height on the Command Center

1. Navigate to Home screen on the Command Center.
2. Tap the *Combine* icon in  the lower right corner of the screen.
3. Tap the third button from the left on the command center to select the *Combine* tab.

- After *Combine* tab is selected, continue to press the third button from the left until page 3 displays (*page numbers are located on the Combine Tab*).

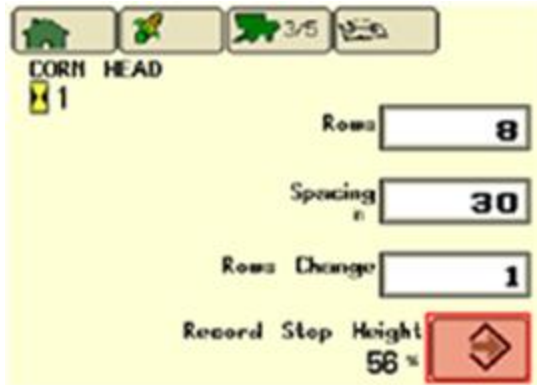

- Position the header to 100%.
- Press **Enter** on *Stop Head Height* screen to record the required stop header height.

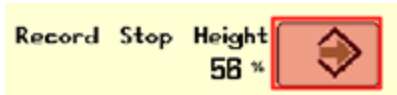

Greenstar Monitor calibrations

Original Greenstar Display (60 Series Combines)

Moisture calibration

- Press **SETUP**.
- Select *Yield Monitor* .
- View page 1.
- Check moisture with a certified tester.
- Calculate moisture correction (*certified tester reading minus the Greenstar reading*).
- Input the moisture difference.

Yield calibration

- Press **SETUP**.
- Tap *Yield Monitor* .
- View page 2.
- Verify that the combine's grain tank and the truck/wagon are both empty, and tap **Start**.

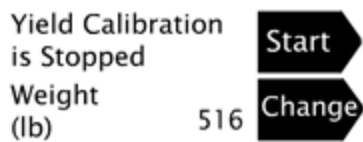

5. Harvest about 500 bushels, and hit **Stop**.

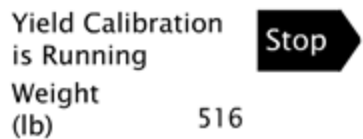



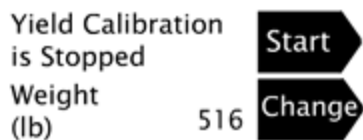

6. Unload the grain harvested during calibration onto truck/wagon.
7. Select button next change to enter the weight of the truck/wagon in wet pounds.



Command Center (70 Series Combines)

Moisture calibration





1. Navigate to Home screen on the Command Center.
2. Tap .
3. Press   on the Command Center.
4. Continue to press   until page 2 displays (page numbers are shown on the Wrench tab).
5. In the *Calibrations* list, select Moisture.



6. Follow the steps to perform the calibration.
7. Highlight the arrow and then press the *Confirm* switch on the armrest.

Yield calibration

Navigate to the Home screen on the Command Center.

1. Tap .
2. Press   on the Command Center.
3. Continue to press   until page 2 displays (page numbers are shown on the Wrench tab).
4. In the *Calibrations* list, select Yield.



5. Follow the steps to perform the calibration.
6. Highlight the arrow and press the *Confirm* switch on the armrest.

Update the Moisture Sensor (60 Series combines only)

Obtain version 1.20C from Stellar Support

1. Go to www.stellarsupport.com.
2. Tap *Support & Downloads* in the left column.
3. Tap *Greenstar System* update from the *Software Downloads* column.
4. Select the green box labeled *Download GSD4 Software*.
5. Tap **Run** in the file download security warning.
6. After the download is complete, choose the preferred language and press **OK**.
7. Follow the Greenstar Update Wizard to load the firmware to the keycard for the original Greenstar monitor.



Load version 1.20C to the Moisture Sensor

1. Insert the updated keycard into the mobile processor that is hooked to the Greenstar display (*it does not matter which slot the keycard is inserted in on the mobile processor*).
2. Power on the Greenstar monitor.

3. Press .

4. Tap **KeyCard** .

5. Tap **Program Target** .

6. Tap **Harvest Monitor Combine**  .
7. Tap **Moisture 1.12J**  .
8. Disconnect the mobile processor after the update is complete.

Operations

In this chapter:

Operations overview	352
Fields	361
Field feature use	364
Guidance pattern use	365
Coverage logging	386
Field-IQ operation	389
Manual guidance operation	401
Autopilot system operation	402
NextSwath operation	405
EZ-Pilot system operation	416
EZ-Steer system operation	419
GreenSeeker operation	422
ISOBUS operation	427
Remote Output operation	429
Row Guidance operation	433
TrueGuide operation	437
TrueTracker operation	439
Vehicle Sync operation	442
Water Management functionality	446
Yield Monitoring operation	482

This chapter covers common user work operations performed at the *Run* screen.

Operations overview

The *Run* screen is where you perform operations. Depending on the features you are using, additional feature buttons will display on the right-hand side of the *Run* screen.

When you begin operations, there are some basic steps you will always perform. If you have already entered implement and vehicle settings:

1. Select a vehicle and an implement.
See [Vehicle selection \(page 363\)](#) and [Implement selection \(page 362\)](#).
2. Select or create client, farm, field and event.
See [Fields \(page 361\)](#).
3. At the *Run* screen:
 - a. Select or create guidance patterns and lines.
See [Guidance pattern use \(page 365\)](#).
 - b. Optionally add field features.
See [Field feature use \(page 364\)](#).
4. Optionally activate coverage logging.
See [Coverage logging \(page 386\)](#).
5. When you are finished, close the field.
See [Close a field \(page 363\)](#).

Operation basics

The process of beginning operation can include:

1. Create or select a field. See [Field creation / selection \(page 361\)](#).
2. Select a vehicle. See [Vehicle selection \(page 363\)](#).
3. Select an implement. See [Implement selection \(page 362\)](#).
4. Load or create a guidance pattern to use. See [Guidance pattern use \(page 365\)](#).
5. Optionally, create field features on-screen to indicate their location in your field. See [Field feature use \(page 364\)](#).
6. Optionally, activate coverage logging. See [Coverage logging \(page 386\)](#).
7. Close the field when operations in that field are complete. See [Close a field \(page 363\)](#).







The system saves an event summary of what has been done in the field. If you want the field to close more quickly, you can change the settings so that you do not save an event summary. See [Event summary adjustment \(page 363\)](#).





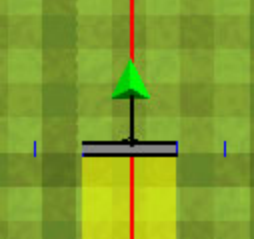

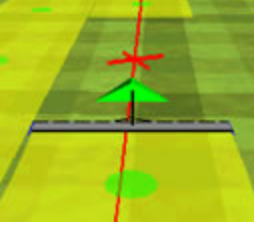
Main buttons

The main buttons on the *Run* screen enable you to:

- See the status of items
- Change the view
- Open feature panels
- Navigate to other screens
- Control automatic steering, if applicable
- Turn coverage logging on or off, if applicable



Left side of *Run* screen

Button/Indicator	Explanation
 GNSS Status	Provides information about GPS. If the GPS signal is lost completely, a warning displays and this button turns red. Tap to view GNSS status (page 360) .
 Overhead view	In the Operational view (page 355) of the <i>Run</i> screen, shows an overhead view of the field, with the vehicle in it. 
 Trailing view	In the Operational view (page 355) of the <i>Run</i> screen, shows a three-dimensional representation of the field from the driver's perspective. 
	Information configured using the Status items (page 79) menus.

Button/Indicator	Explanation
 Zoom / Pan	<p>Opens the zoom and pan controls for the Operational view (page 355). With the pan function, you can view the field outside of the normal viewing area.</p>   <p>To pan around the field, tap one of the four arrows positioned at the edge field area.</p> <p>To zoom in and out, tap either plus or minus </p> <p>Note – To toggle the zoom feature on or off, tap the field area of the Run screen.</p> <p>The fifth level of zoom in the pan view  is a summary view of all your coverage. It adjusts, depending on the size of the field. It does not include grid lines.</p> <p>Tip – If you close the field, create a second field and then show the summary view, the summary view may be zoomed to show the area of both fields. To avoid this, reboot the display and open FM-1000 Plus application. The view will be correct.</p>
	<p>Tap to see a listing of all optional features/plugins and their description.</p>
xFill icon	<p>xFill is activated, displays in the top left:</p> <ul style="list-style-type: none"> • Blue: Engaged and has been used between 0 - 15 minutes • Red: Engaged and 5 minutes remain

Right side buttons on *Run* screen

The following buttons are the standard buttons on the right that are always available.

Item	Explanation
 Home	If you are at the <i>Run</i> screen and have a field open, tap to close the field and return to the <i>Field Selection</i> screen. See Close a field (page 363) .
 Settings	Tap to go to the <i>Configuration</i> screen. See Configuration screen (page 44) .
 Mapping guidance	Tap to open the Mapping Guidance panel. See: <ul style="list-style-type: none"> • Feature panels (page 356) • Guidance pattern use (page 365) • Guidance settings (page 66)

Also see:

- [Coverage logging \(page 386\)](#)
- [Engage button \(page 359\)](#)

Operational view

The operational section of the *Run* screen shows your guidance lines and an on-screen representation of your vehicle in the field. Hashed grids provide a measure of distance. Each small square represents 10 feet, and each dark green outline represents 50 feet.



You can change your view from an overhead view to a trailing view. See [Main buttons \(page 353\)](#).

Feature panels





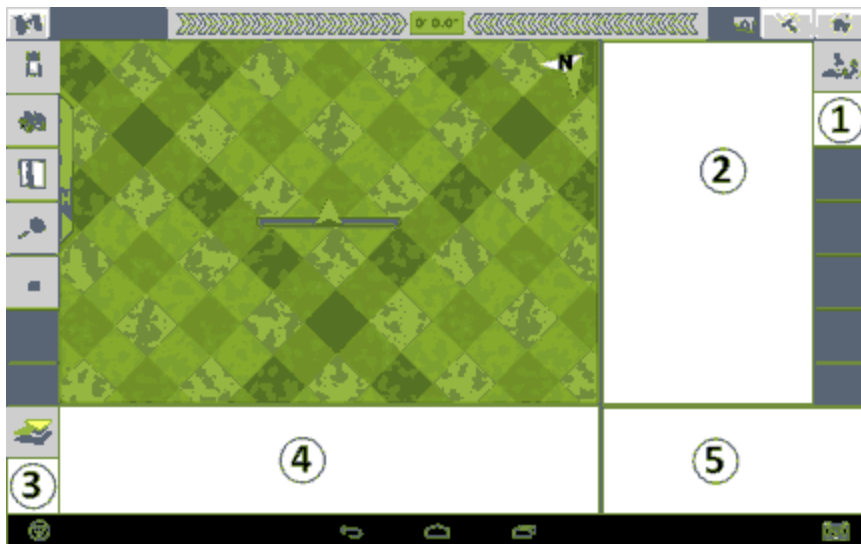







On the *Run* screen, you open a feature panel to view controls related to that feature. The [feature buttons](#) display on the right-hand side of the screen.











One feature is always on the *Run* screen:  opens the Mapping Guidance panel.

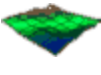

Item	Explanation
1	Location for feature buttons . Tap to open the feature panel.
2	Feature panel. Contains controls specifically related to the feature.
3	Optional control button. Tap to open additional views related to the feature.
4	Additional information related to the feature.
5	Area for controls such as the coverage logging and Engage button when applicable. See: <ul style="list-style-type: none"> • Coverage logging (page 386) • Engage button (page 359)

Feature / plugin buttons

Button	Opens the feature panel for...
	TrueGuide implement control system. See Using TrueGuide (page 438) .
	Autopilot automatic steering system. See Autopilot system operation (page 402) .
	EZ-Pilot automatic steering system. See EZ-Pilot system operation (page 416) .
	EZ-Steer automatic steering system. See EZ-Steer system operation (page 419) .
	Field-IQ application control system. See Field-IQ operation (page 389) .
	FieldLevel II. See Leveling (page 450) .
	FieldLevel II, tandem. See Tandem scraper controls (page 463) and Tandem / dual scraper setup (page 317) .
	GreenSeeker. See GreenSeeker functionality (page 258) .
	Guidance mapping. See Guidance pattern use (page 365) and Field feature use (page 364) .
	ISOBUS Task Controller. See Task Controller operation (page 427) .
	ISOBUS Virtual Terminal. See Virtual Terminal operation (page 428) .
	Manual guidance. See Manual guidance operation (page 401) .

Button	Opens the feature panel for...
	NextSwath. See NextSwath settings (page 189) .
	Remote Output. See Remote Output setup (page 136) .
	Row Guidance. See Row Guidance operation (page 433) .
	Serial Rate Control. See Variable rate controller setup (page 271) .
	Survey. See Create a survey (page 446) .
	TrueGuide system. See TrueGuide operation (page 437) .
	TrueTracker system. See TrueTracker operation (page 439) .
	Vehicle Sync. See Vehicle Sync (page 302) .
	WM-Drain. See WM-Drain operation (page 464) .
	Yield Monitoring. See Yield Monitoring operation (page 482) .





Engage button



WARNING – Many large and sudden changes in satellite geometry caused by blocked satellites can cause significant position shifts. If operating under these conditions, auto-guidance systems can react abruptly. To avoid possible personal injury or damage to property under these conditions, disable the auto-guidance system and take manual control of the vehicle until conditions have cleared.



The **Engage** button displays on the *Run* screen when you are using an automatic steering system such as:

- [Autopilot system operation \(page 402\)](#)
- [EZ-Pilot system operation \(page 416\)](#)
- [EZ-Steer system operation \(page 419\)](#)

Indicator/Button	Explanation	Tap to...
 Ready to Engage (yellow)	The vehicle is close enough to the guidance line to engage on it.	Engage on the guidance line.
 Engaged (green)	The vehicle is engaged on the guidance line.	Stop engaging on the guidance line.
 Not Ready to Engage (red)	The vehicle is not ready to engage on the line because the guidance line is too far from the vehicle.	N/A. You cannot tap this button. It is an indicator only.
 Auto steering not allowed (red)	Automatic steering is not allowed due to how it has been set up.	N/A. You cannot tap this button. It is an indicator only.

Coverage button for logging

When you are applying material, the coverage button displays on the *Run* screen. The coverage button controls whether or not you are logging the coverage you are applying.

Indicator/Button	Explanation
 Logging Off	Indicates coverage logging is off. Tap to start logging.
 Logging On	Indicates coverage logging is on. Tap to stop logging.

See [Coverage logging \(page 386\)](#).

GNSS status



CAUTION – The GNSS antenna may experience interference if you operate the vehicle within 100 m (300 ft) of any power line, radar dish, or cell phone tower.

Tap  to see status information on GNSS.

If the feature/plugin you are using has a second GNSS receiver, there will be a satellite icon for both receivers. Tap the other  to see status on the second GNSS receiver.

On-screen lightbar for vehicle

The on-screen lightbar indicates where the vehicle is in relation to the guidance line.

- Green in center: The vehicle is on the guidance line exactly



On-screen lightbar for implement

There can be more than one row of lights, depending on the feature/plugin that is being used. The second row shows where the implement is in relation to the guidance line.

See [Implement on-screen lightbar \(page 440\)](#).

Fields

The FM-1000 Plus application Data Dictionary organizes all work performed based on a Client / Farm / Field / Event structure.

Field creation / selection

- To change the vehicle or implement, tap **Switch** next to the item and select the one you want.
- Tap **OK**. The *Field Selection* screen displays.
 - For existing client, farm, field or events, select the appropriate choice from each list.
 - To create new items, tap **New**.

Item	Explanation
Client	Select the client. The Farm list will show only farms associated with this client.
Farm	Select the farm. The Field list will show only fields associated with this farm.
Field	Tap New . Enter the new field name.
Event	Select the event.
Event Attributes	Tap to add more information for record keeping.
Variety Setup	Tap to add and edit information on the variety of products that can be distributed from the implement, tap Hybrid Setup .

- Tap **OK** to enter the *Run* screen.

After you create the field, select a swath pattern to use while you drive the field. See [Field creation / selection \(page 361\)](#).

Event Attributes screen

Category	Explanation
Operator Name	Name of the vehicle's operator
Operator EPA#	Vehicle operator's EPA license number. For spreading restricted-use or state-restricted pesticides or herbicides.
Harvest Year	Year the crop will be harvested

Category	Explanation
Farm Location	Country or region where the farm is located
Vehicle	Vehicle used in the operation
Implement	Implement connected to the vehicle
Application method	Method used, such as spraying, seeding, harvesting and so on
Wind speed	Average wind speed
Wind gust speed	Maximum speed of any wind gusts
Wind direction	Average wind direction
Sky conditions	Amount of cloud cover
Soil conditions	Description of the soil's state
Soil type	Description of the soil type
Temperature	Current temperature
Relative humidity	Percentage of humidity
Crop	Crop in the field
Target pests	Pests to be eliminated by spraying
Custom 1	Additional information you enter
Custom 2	Additional information you enter
Custom 3	Additional information you enter
Custom 4	Additional information you enter
Material	Material being applied

Implement selection

1. At the *Home* screen, tap . The *Configuration Selection* screen displays.
2. Next to the existing implement, tap **Switch** to select to a different implement.

Vehicle selection

1. At the *Home* screen, tap . The *Configuration Selection* screen displays.
2. To change the vehicle currently selected, tap **Switch** to select to a different vehicle.

Event summary adjustment

When a field is closed, the system saves an HTML summary for the event.

To reduce the time it takes to close a field, you can prevent the system from saving a summary:

1. At the *Configuration* screen, select *System* and then tap **Setup**.
2. At the *Display Setup* screen, select *Map Settings* and then tap **Setup**.
3. At the *Mapping* screen, select *Off* from the *Save Summaries* list.

Close a field

After you finish using a field, tap  to close it. The system displays a message asking what you want to do next. These options are:

Tap...	To...
Cancel	Return to the currently open field.
Close	Close the current field and return to the <i>Home</i> screen.
Open Another	Close the current field, and open a new field.

Field feature use

You can place field features in the field while driving to define on the field points of interest or areas to avoid. There are three types of field feature:

- Point: A single point in the field, such as a tree
- Line: A straight or curved line in a field, such as a fence
- Area: An area of land, such as a pond

Field feature buttons display on the Guidance Mapping panel at the *Run* screen.

Add field features

To add a feature to the on-screen map of your field:

1. At the *Run* screen, tap  to open the Mapping Guidance panel, which contains the buttons for field features you defined.
2. Begin to drive the field.
3. When you reach the point in your field where you want to add a feature, tap the appropriate feature button. If the feature is a line or area feature, the feature will begin. To mark the end of the line or feature, tap the feature button again.

Note – You can add a point feature while adding a line or area feature. For example, use a line feature to draw an overhead telephone wire and at the same time use a point feature to add the telephone poles.

To set up feature buttons, see [Field feature mapping settings \(page 65\)](#).

Guidance pattern use

Guidance patterns enable you to either:

- Manually steer on the guidance lines of the pattern using the on-screen lightbar to guide your accuracy
- Use an automatic steering system to engage on and drive on the guidance lines of the pattern

The swath measurement is based on the implement width you are using.

Creating patterns

The guidance pattern types available in the FM-1000 Plus application to create are:

- Straight swaths created using an AB line or an A+ line (see [Straight guidance pattern \(page 369\)](#))
- [Curved pattern \(page 371\)](#)
- Circular pivots. See [Pivot pattern \(page 374\)](#).
- Headlands. See [Headland pattern \(page 372\)](#).
- Free form patterns. See [FreeForm pattern \(page 376\)](#).

Access paths

With some guidance patterns, you can add an access path that provides a space such as for a road. See [Access paths \(page 379\)](#).







Existing patterns

After you have created a guidance pattern, you can choose it from the list and:

- Load it for use. See [Load a pattern \(page 381\)](#).
- Shift it. See [Shift a swath \(page 383\)](#).
- Rename it. See [Rename a swath \(page 381\)](#).
- Delete it. See [Delete a swath \(page 383\)](#).

Guidance mapping controls

When you tap  at the *Run* screen, the Mapping Guidance panel displays with controls for features and guidance. The following controls may display in the Mapping Guidance panel, depending on the function you are performing.

Button	Tap to...
Done	Finish an A+ or an AB line.
Feature buttons	Create features in the field, such as boundary, rock, fence and so on. See Field feature use (page 364) .
 Next	Load the next master line in the Swaths library with each tap. <i>Note</i> – The active master line name will be displayed on the <i>Run</i> screen.
	Project a straight line in front of the on-screen vehicle.
 Pause	Pause recording a path.
 Resume	Stop pausing and resume recording the path.
 Record	Record the path you are driving.
 Stop Recording	Stop recording the path you are driving.
Set A	Set the A point of an AB line.
Set B	Set the B point of an AB line.
Skip	Skip a swath (page 385) .
 Swaths	Open the Swaths Management screen .
Use A+	Set the point of an A+ line.

Swaths Management screen

From the Mapping Guidance panel, you can access the *Swaths Management* screen by tapping



. The tabs on this screen are:

Tab	On this tab, you can:	See...
Swaths	Choose the type of pattern you want to create	Straight guidance pattern (page 369) Curved pattern (page 371) Headland pattern (page 372) Pivot pattern (page 374)
	Shift, rename or export an existing pattern	Rename a swath (page 381) Shift a swath (page 383)
	Import or delete an existing pattern	Import AB Lines or boundaries (page 380) Delete a swath (page 383)
	Add an access path	Access paths (page 379)
Line Features	A list of line features you have created and can load.	Field feature use (page 364)
FreeForm	Set when the path is recorded and whether you want the U-turn at the end of a path to be recorded. Delete all line segments created in your FreeForm pattern.	FreeForm pattern (page 376)
Features	A list of features you have created in the field.	Field feature use (page 364)

The buttons on the bottom of the *Swaths Management* screen are:

Buttons	Tap to...	See...
No AB	Prevents the AB guidance lines from being loaded (for WM Form activities).	
New FreeForm	Begin a new FreeForm line and go to the <i>Run</i> screen.	FreeForm pattern (page 376)
Load	Load a new pattern.	Load a pattern (page 381)
Close	Close the <i>Swaths Management</i> screen and	

Buttons	Tap to...	See...
	return to the <i>Run</i> screen.	
New Straight	Begin a new straight line and go to the <i>Run</i> screen.	Straight guidance pattern (page 369)
Import	Open the <i>Import Swaths</i> screen to import AB lines or boundaries.	Import AB Lines or boundaries (page 380)

Straight guidance pattern

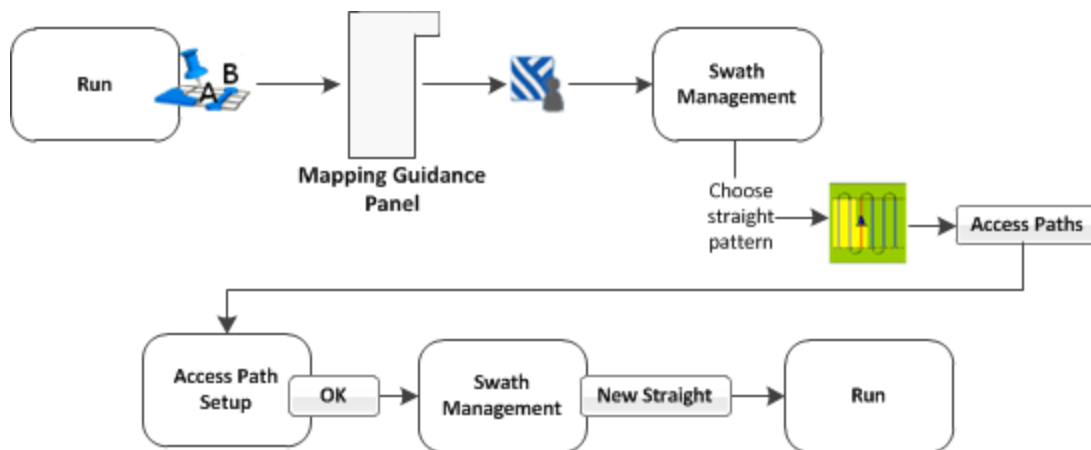
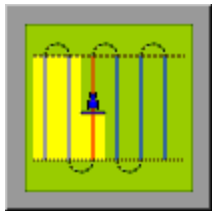

There are two ways to create a straight guidance pattern:

- Create an AB Line: Define the start and end points.
- Create an A+ Line: Define a point on the line and the heading direction.



AB line creation

To create a straight AB line:

1. At the *Run* screen, tap  to open the Mapping Guidance panel.
2. Tap  **Swaths**.
3. At the *Swath Management* screen, select the AB pattern from the pattern list.
4. Enter an access path, if required. See [Access paths \(page 379\)](#).
5. Tap **New Straight**. The *Run* screen displays.
6. To create the start point of the line, tap **Set A**.
7. Drive to the end of the line.

Note – The end (B) point must be at least 50 meters (160 feet) from the A point.

8. Tap **Set B**. The new AB line displays.
9. To extend the line, drive further along it and then tap **Set B** again.
10. Tap **Done** to indicate you have finished.
11. The system automatically creates the remaining swaths. If you need to shift or skip a swath, see:
 - [Shift a swath \(page 383\)](#)
 - [Skip a swath \(page 385\)](#)

A+ line creation



To create a straight A+ line:

1. At the *Swath Management* screen, select the A+ pattern from the pattern list.
2. Enter an access path, if required. See [Access paths \(page 379\)](#).
3. In the A+ Heading entry box, enter the angle that you want the line to be on or select a previous AB Line to use its heading.

Note – The default angle is the same as the previous AB Line heading.
4. Tap **New Straight**. The *Run* screen displays.
5. Drive to the start of the line and then tap **Set A**.
6. Tap **Use A+**. The new A+ line displays.
7. Tap **Done**.
8. The system automatically creates the remaining swaths. If you need to shift or skip a swath, see:
 - [Shift a swath \(page 383\)](#)
 - [Skip a swath \(page 385\)](#)

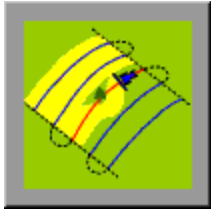
Curved pattern



1. At the *Run* screen, tap  to open the Mapping Guidance panel.
2. Tap  **Swaths**.
3. At the *Swath Management* screen, select the Curve pattern from the pattern list.
4. Enter an access path, if required. See [Access paths \(page 379\)](#).
5. Tap **New Curve**. The *Run* screen displays.

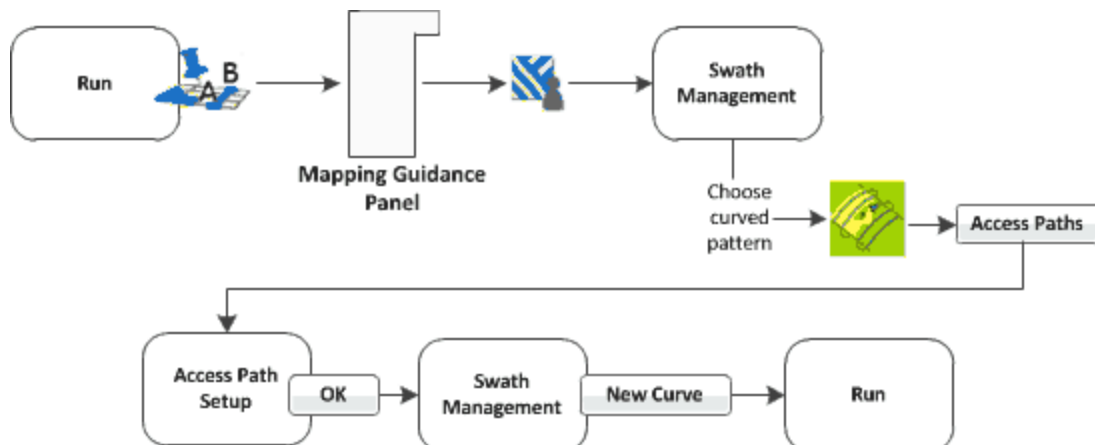



6. Drive to the start point of the curve and then tap **Set A**.
7. To stop recording your exact path and create a straight section of line, tap **Record**.
8. Drive the curve until you reach the end point and then tap **Set B**. The new curve pattern displays showing all the swaths the system automatically generated.
9. If you need to shift or skip a swath, see:
 - [Shift a swath \(page 383\)](#)
 - [Skip a swath \(page 385\)](#)

Headland pattern

A headland is a straight AB Line or an A+ line pattern that is confined inside a boundary. This boundary is called the headland.



Note – If you want to create a headland based on the A+ line pattern, select the straight line pattern and then set the A+ heading for the internal line. Then complete the following steps.

1. At the *Run* screen, tap  to open the Mapping Guidance panel.
2. Tap  **Swaths**.
3. At the *Swath Management* screen, select the Headlands pattern from the pattern list. In the # Headlands entry box, enter the width of the headland boundary in swaths. For example, if you enter 2, the headland will be two swaths wide.
4. Tap **New Headland**. The *Run* screen displays.

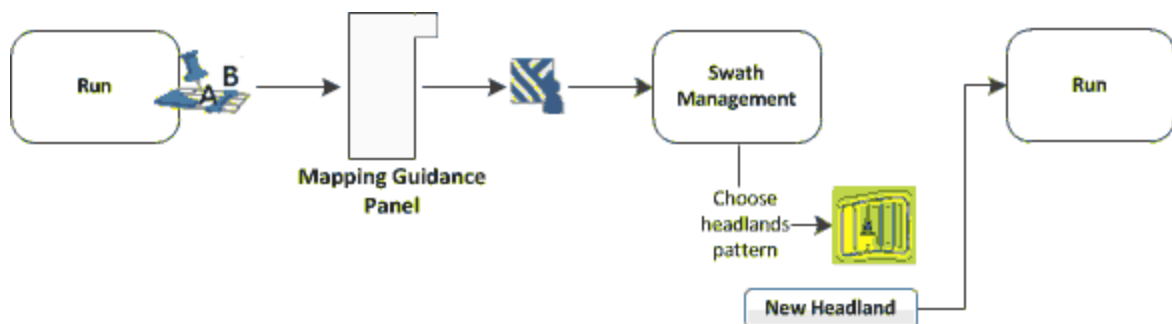



5. Drive to the start point of the headland and then tap . A red line displays behind the vehicle to show that the headland is being recorded.
 6. Define the inner pattern before you complete the headland. To do so, tap **Infill**. The Mapping Guidance panel changes to show the inner pattern buttons.
- Note** – After infill lines have been created, they cannot be moved.
7. When you reach the location for the A point, tap **Set A**.
 8. To create an internal AB Line, drive to the location for the B point (at least 50 m (164 ft)) and then tap **Set B**.
 9. To create an internal A+ line, tap **Use A+**.

10. Tap **Back to HL**. The Mapping Guidance panel returns to its original appearance.
11. When you complete the headland circuit, the system will draw a straight line from the vehicle back to the start point. Drive the vehicle to a position on the headland circuit where a straight line back to the start will not cut off part of the pattern.
12. Tap **Close HL**. The new headland displays showing all the swaths that the system has automatically generated.
13. If you need to shift or skip a swath, see:
 - [Shift a swath \(page 383\)](#)
 - [Skip a swath \(page 385\)](#)

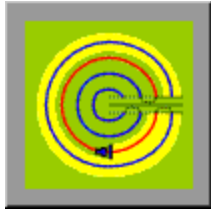
Pivot pattern



1. At the *Run* screen, tap  to open the Mapping Guidance panel.
2. Tap  **Swaths**.
3. At the *Swath Management* screen, select the **Pivot** pattern from the pattern list.
4. Tap **New Pivot**.
5. The *Run* screen displays.

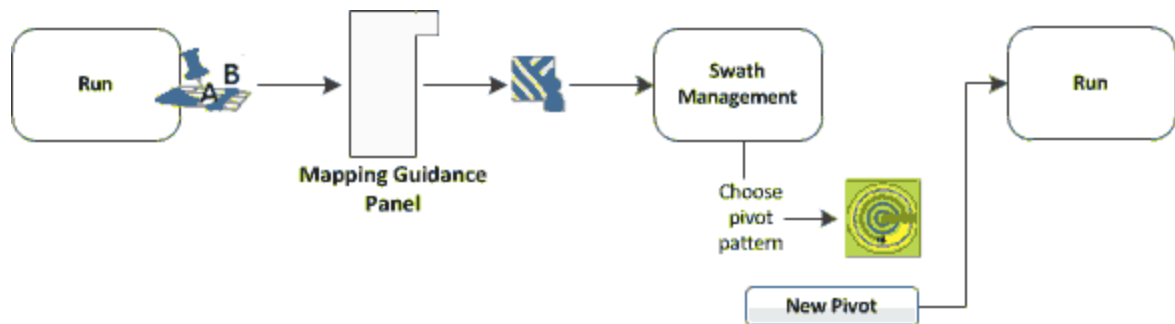

6. Drive to a point on the outermost rut of the pivot and then tap **Set A**.
7. Follow the pivot rut around to the end and then tap **Set B**. The *Enter Distance to Pivot Field Edge* screen displays.
8. Enter the distance or the number of rows from the current path to the outside of the pivot and then tap **OK**. The pivot displays, showing the swaths it generated.
9. If you need to shift or skip a swath, see:
 - [Shift a swath \(page 383\)](#)
 - [Skip a swath \(page 385\)](#)

Outer edge radius adjustment

The pivot has an outer edge radius that is used to calculate the coverage area. After you create a pivot, you can adjust this outer edge radius.

1. At the *Run* screen, tap **Swaths**. The *Swath Management* screen displays.
2. Select the pivot to be adjusted from the list of available pivots.

Note – *The default is the AB curve.*

3. In the Outer Edge Radius entry box, adjust or enter the value that represents the distance from the pivot center to the outer edge and tap **OK**. The *Swath Management* screen displays.
4. To update the pivot, tap **Load**. The *Run* screen displays with the new pivot dimensions.

FreeForm pattern



Using the FreeForm pattern, you can create non-symmetrical guidance paths in fields that have irregular shapes. FreeForm combines these patterns:

- Straight line guidance segments
- Curved guidance segments



With this combination, you can use the FreeForm pattern to create circular spirals or guidance lines with curved and straight line segments for irregular-shaped fields as well as rugged topographics.



Unlike the other patterns where the next swath is repeated, you must drive and record all paths.

Create a FreeForm pattern

1. At the *Run* screen, tap  to open the Mapping Guidance panel.
2. Tap  **Swaths**. The *Swath Management* screen displays.
3. Select the *FreeForm* tab and complete the settings.

Setting	Explanation
Record Swath	<ul style="list-style-type: none"> • Manually: Use the record button to record the path. • When Logging: Record the path when you are logging coverage. Note – If you have an external remote logging switch that controls coverage logging, the system records FreeForm curves when the remote logging switch is enabled).
U-Turn Detection	<ul style="list-style-type: none"> • Auto: Do not record the U-turn at the end of a path. • None: Do record the U-turn at the end of a path.
Delete All	Removes all segments of the FreeForm pattern you have recorded.

4. Tap **New FreeForm**.
5. To begin recording, you can either:
 - Tap .
 - Tap  (if you have set up to record logging coverage while you are engaged. See [Engage settings for Autopilot system \(page 165\)](#), [Engage settings for EZ-Pilot system \(page 201\)](#) or [Engage settings for EZ-Steer \(page 206\)](#) and [Coverage logging \(page 386\)](#)).
6. To stop recording, you can:

- Tap  if you are recording manually.
- Tap  to stop logging coverage (if you have set up to record logging while you are engaged. See [Engage settings for Autopilot system \(page 165\)](#), [Engage settings for EZ-Pilot system \(page 201\)](#) or [Engage settings for EZ-Steer \(page 206\)](#) and [Coverage logging \(page 386\)](#)).

7. To create a straight line within a FreeForm path:

- Make sure you are actively recording and the vehicle is moving forward.
- Tap . The system projects a straight dashed line from the front of the on-screen vehicle based on the current heading.



You can immediately engage on this line and the path driven is recorded.

- To stop recording the path, disengage automatic steering by either tapping  to disengage the automatic steering or moving the steering wheel more than 5 degrees.

Pause recording

You can pause recording and then begin recording again. This is useful when you encounter areas or objects you are driving around but will not need to drive around on the next line.

- Tap .
 - A pause indicator displays on map.
 - A straight dashed line projects from the rear of the moving vehicle based on the current heading.



- The pause button changes to .

- Your position is saved to a file on the FM-1000 Plus application. You can then close the field and power off the display. When you open the field again, you will be guided back to your former position.
2. When you have returned to your desired position (for example, after driving around an obstacle), tap  to stop the pause and snap a straight line from the initial pause location and the current vehicle position.

Access paths

An access path is a space between your guidance lines. These paths can be useful if there is road (or other field feature that breaks the consistent flow of swaths) through the middle of your field.

Note – You can add access paths on a straight or curved pattern, but not headlands or pivots.

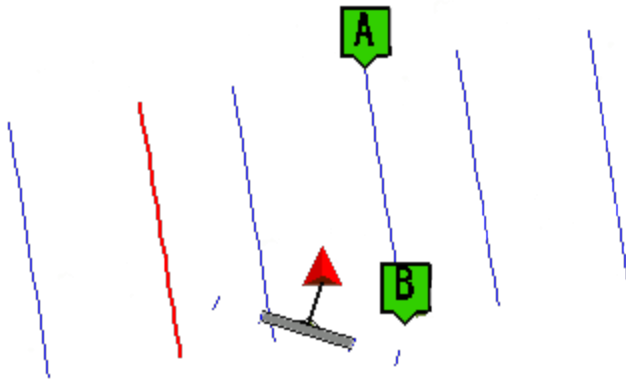

1. At the *Run* screen, tap  to open the Mapping Guidance panel.

2. Tap  **Swaths**.

3. At the *Swath Management* screen, tap **Access Paths**. The *Access Path Setup* screen displays. Complete the settings on this screen and tap **OK**.

Setting	Explanation
Swaths between access paths	This value must be equal to or higher than the Swaths in first group setting. The next access path will display this number of swaths beyond the first access path, and will continue to repeat after this number of swaths. The access path will display after this number of swaths (including the master line).
Path width	Width of the access path
Swaths in first group	Enter the number of swaths
ABs place in the first group (left to right)	Enter a value in the ABs place in the first group (left to right) entry box. This setting enables you to specify where the master line displays in the first group (from left to right).
Provide Guidance to	Select whether guidance will be based on swaths or access paths.

Switch to the next pattern

You can switch from one existing line pattern to another. To do so, tap .

Each time you tap , the system changes the line pattern to the next pattern available in the list on the *Swaths Management* screen (Swaths tab).

The system switches to the next available pattern and displays the name of the active pattern on the Mapping Guidance panel.

Note – *FreeForm* cannot be actively recording the path for the Next button to be active.

Import AB Lines or boundaries

The FM-1000 Plus application can load field boundaries and AB Lines created by:

- A Remote Data Logger (RDL)
- A Geographic Information System (GIS)

Note – To load GIS boundaries, files must be in WGS-84 latitudes, longitudes, and heights in decimal degrees.

To import an AB Line or a boundary into the FM-1000 Plus application:

1. Insert the USB drive into an office computer.

The three files that define a line or field (.shp, .shx, and .dbf) must have identical names. Otherwise, they are not recognized. If you put multiple sets of files in the folder, ensure that you do not have more than one set of files with each name or your files will be overwritten.

2. Copy the following files to the \AgGPS\AB Lines\ folder on the USB drive:

- <field name>.shp
- <field name>.shx
- <field name>.dbf

3. Power on the display and open the FM-1000 Plus application. Tap .

4. Either open an existing field or start a new field.

5. Tap  **Swaths**.

6. Tap **Import**. The *Import Swaths* screen displays.

7. Tap the field or AB Line to import from the list of available swaths and then tap **OK**. The field or AB Line is imported.

If the AB Line file contains more than one AB Line, all AB Lines in the file are imported.



8. Tap the AB Line that you want to use and tap **Load**. A warning message displays.

9. Tap **OK**. The imported field or AB Line is ready to use.
10. For best results, close the field and then reopen it.

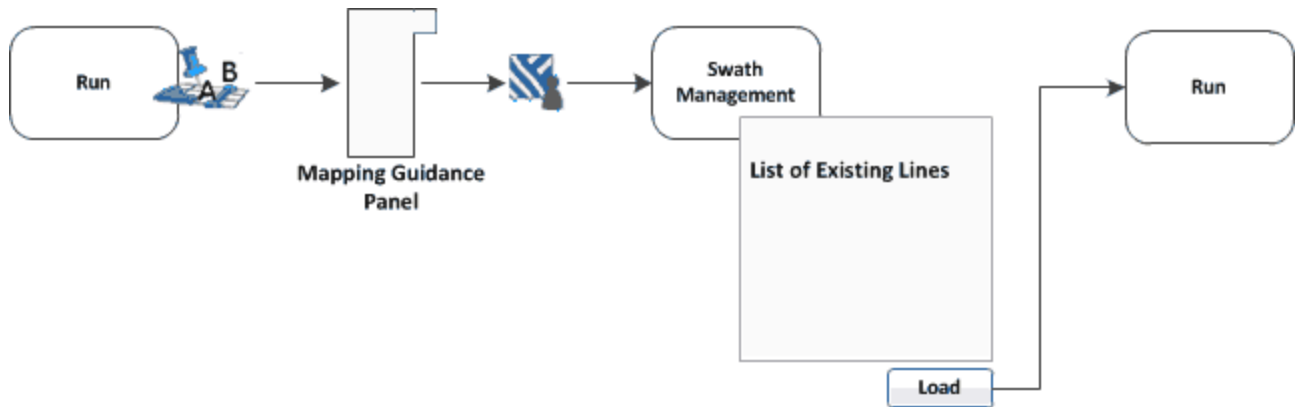
Load a pattern



To load a line/pattern you previously created in a field:

1. At the *Run* screen, tap  to open the Mapping Guidance panel.
2. Tap  **Swaths**. The *Swath Management* screen displays.
3. To load a pattern, select it from the list on the left of the screen. The system loads the closest pattern to you.
4. Tap **Load**. The *Run* screen displays, with the pattern loaded.



If you try to load a pattern that is over 100 km (63 miles) away, the following message displays:

Your current position is too far from the field to work in it.

Rename a swath

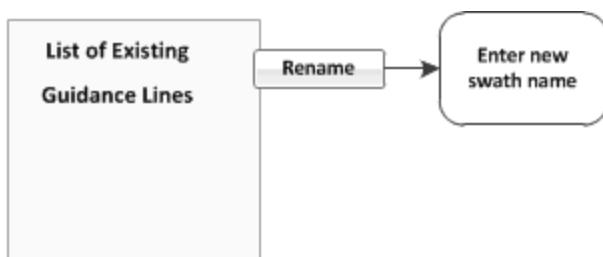
Note – To rename swaths, you must have entered the administration password. You cannot rename line features or FreeForm curves.



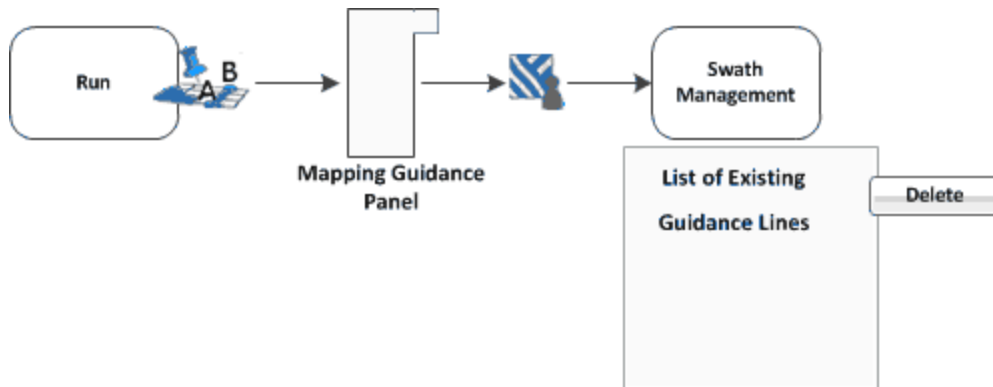

1. At the *Run* screen, tap  to open the Mapping Guidance panel.
2. Tap  **Swaths**. The *Swath Management* screen displays.
3. From the list on the left, select the swath to rename.
4. Tap **Rename**. If prompted, enter the password. The *Enter new swath name* screen displays.
5. Enter the new name for the swath and tap **OK**. The *Swath Management* screen displays again.
6. To return to the *Run* screen, tap **Close**.

Delete a swath



Note – To be able to delete swaths, you must have entered the Administration password.

1. At the *Run* screen, tap  to open the Mapping Guidance panel.
2. Tap  **Swaths**. The *Swath Management* screen displays.
3. From the list on the left, select the swath to delete.
4. Tap **Delete**. If prompted, enter the password. The swath is marked as deleted. The next time you close the current field, the swath does not show in the list.

Note – You cannot delete a swath that is currently active.

5. To return to the *Run* screen, tap **Close**.

Switch to the next pattern

You can switch from one existing line pattern to another. To do so, tap .

Each time you tap , the system changes the line pattern to the next pattern available in the list on the *Swaths Management* screen (Swaths tab).



The system switches to the next available pattern and displays the name of the active pattern on the Mapping Guidance panel.

Note – *FreeForm* cannot be actively recording the path for the Next button to be active.

Shift a swath

Note – Shifting a swath is a permanent adjustment. To temporarily change the spacing of swaths, skip a swath instead. See [Skip a swath \(page 385\)](#).

Note – You cannot shift line features or *FreeForm* curves.

1. At the *Run* screen, tap  to open the Mapping Guidance panel.
2. Tap  **Swaths**. The *Swath Management* screen displays.
3. Select the swath to shift from the list on the left.
4. Tap **Shift**. The *Enter the Shift Distance* screen displays.

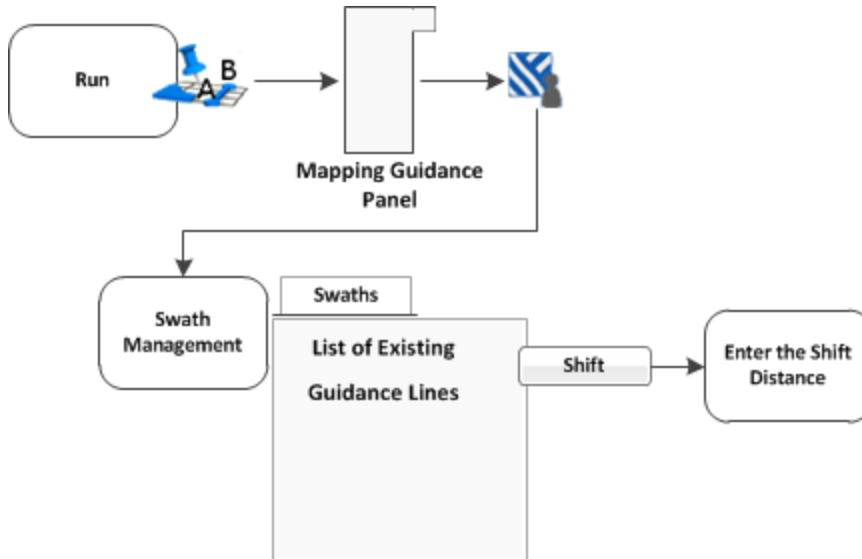

5. Enter the values.

Setting	Tap to...
Left	Shift the line to the left of your view.
Right	Shift the line to the right of your view.
Value entry boxes	Enter the distance you want to shift the line.
Metric	Change to metric values.
Feet & Inches	Change to feet and inches.
Decimal Feet	Change to decimal feet.
Rows	
Calculator	Open the calculator.

Note – If you shift a line, it will shift the original version of the line and remove any skip that you have applied.

6. Tap **OK**. The *Swath Management* screen displays. The newly shifted swath displays in the swath list on the left of the screen.

Skip a swath

Note – The *Skip* position of a swath line is temporary and is not saved permanently. To save such an adjustment, shift the swath instead. See [Shift a swath \(page 383\)](#).

FM-1000 Plus application uses the original swath that you drove to automatically generate the position of the other swaths. Occasionally, the on-screen swaths do not accurately indicate where your swaths are. For example, you may need to skip a swath to drive to the other side of a road.

To temporarily correct the spacing of the automatically generated swaths in a field:

1. At the *Run* screen, tap  to open the Mapping Guidance panel.
2. Tap **Skip**. The *Enter the Skip Distance* screen displays.
3. Complete the settings.

Setting	Tap to...
Left	Shift the line to the left of your view.
Right	Shift the line to the right of your view.
Value entry boxes	Enter the distance you want to skip to the next swath.
Metric	Change to metric values.
Feet & Inches	Change to feet and inches.
Decimal Feet	Change to decimal feet.
Rows	
Calculator	Open the calculator.



The swath line moves the required amount.

4. Tap **OK**. The *Swath Management* screen displays. The newly shifted swath displays in the swath list on the left of the screen.

Note – The skip occurs based on the direction of the vehicle, not on the A-to-B orientation of the line. For example, if you select *Left*, the line shifts to the left of your view.

Coverage logging

When you are applying material, the coverage button displays on the *Run* screen. The coverage button controls whether or not you are logging the coverage you are applying.

Indicator/Button	Explanation
 Logging Off	Indicates coverage logging is off. Tap to start logging.
 Logging On	Indicates coverage logging is on. Tap to stop logging.



When the system logs coverage, it records the area that you have covered when you carry out an operation (such as applying fertilizer to a field).

If you have chosen to log coverage, the covered area displays on the *Run* screen as a pale yellow area that shows:

- Coverage the first time
- Any skips in coverage
- Areas you covered twice or three times

Coverage logs record more than the applied material. See [View coverage layers \(page 386\)](#) and [Log coverage for varieties \(page 387\)](#).

You can begin logging coverage:

- Manually by tapping 
- Automatically if you are using automatic steering and tapping . See [Engage settings for Autopilot system \(page 165\)](#), [Engage settings for EZ-Pilot system \(page 201\)](#), or [Engage settings for EZ-Steer \(page 206\)](#).

If you are applying a variety of materials, you can set up coverage to show the varieties. See [Log coverage for varieties \(page 387\)](#).

View coverage layers

1. To see different aspects (or layers) of coverage on the screen, tap  on the lower left side of the screen.
2. Select the layer you want to view.

Layer	Explanation
Overlap	General coverage and overlap
Height	Altitude of GPS receiver
GPS Quality	Quality of GPS signal
Cut/Fill	Cut or fill (for water management operations)
Variety	Different varieties being applied
Applied Rate	Rate at which material is being applied
Speed	Speed of the vehicle
Average Cross Track Error (XTE)	Position of the vehicle in relation to the guidance line

Log coverage for varieties

By default, coverage is displayed on the screen as a pale yellow. However, if you are applying varieties, you can set up the system to make different varieties visible on the screen.

By logging varieties, you can:

- Change product in a field, so that you can later identify which parts of the field are covered in which product.
- Plant or apply two or more different products side by side and record the locations in your field. For example, track the planting of:
 - Corn seed in the left side hoppers
 - Clover seed in the right side hoppers

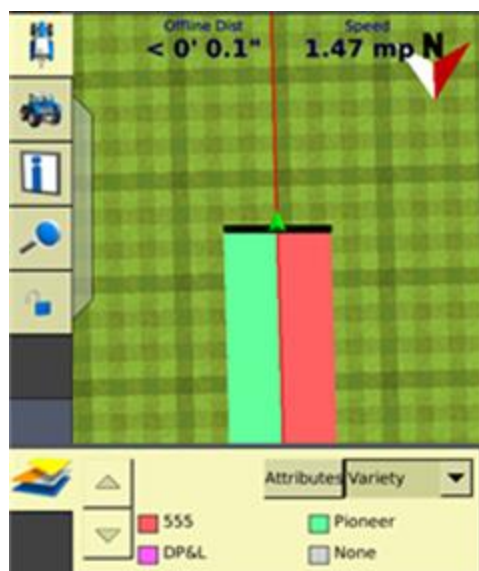

Varieties are assigned to rows on your implement. Specify the number of rows on your implement when you configure it. For more information, see [Edit implement settings \(page 158\)](#).

Set up variety logging

To log varieties:

1. At the *Home* screen, tap . The *Field Selection* screen displays.
2. Tap **Hybrid Setup**. The *Hybrid Setup* screen displays. Use this screen to complete the settings for hybrids.

Setting or Button	Explanation
Left-hand list	List of varieties.
Add	Add a new variety and select a name for it.
Remove	Select a variety name in the left-hand list and tap Remove to delete it.
Edit	Select a variety name in the list and tap Edit to change the settings. The <i>Variety Attributes</i> screen displays. Enter a name for the variety, choose the color to display for the variety and optionally complete additional record keeping information.
Assign	Select the variety from the left-hand list and tap Assign . For each variety, select the row numbers on your implement that will be applying the variety.
Clear	Tap to clear all current entries.

3. When you have finished with the settings, tap **OK**.

When you enable coverage logging and set the Mapping Guidance panel list to *Variety*, this variety color displays in the guidance window.

Tip – For quick access to the *Hybrid Setup* screen from the *Run* screen, set the Mapping Guidance panel list to *Variety* and then tap **Attributes**.

If you select a different implement or change the settings of the current implement, the variety assignments are removed.

Field-IQ operation



WARNING – When the implement is down and the master switch is in the On position, the machine is fully operational. Take all necessary precautions to ensure user safety. Failure to do so could result in injury or death.

1. At the *Home* screen, tap  .
2. At the *Current Configurations* screen, configure the display/vehicle/ implement settings and then tap **OK**.
3. At the *Field Selection* screen, select the required client/farm/field/event settings and then tap **OK**.

For setup information, see [Field-IQ system setup \(page 218\)](#).

Field-IQ panel

To open the Field-IQ panel, tap . The panel displays. Within the panel, you can navigate to many views:

- [Material detail view \(page 390\)](#)
- [Row detail view \(page 392\)](#)
- [Section control view \(page 393\)](#)

Material detail view

The main view shows a list of materials. Up to six materials are listed. The current target and actual rates are shown for each material.

	corn	Target 30.00 kS/a Actual 0.00 kS/a
	10-34-0	Target 0.00 gal/a Actual 0.00 gal/a
	granular seed	Target n/a Actual 0.00 lbs/a
	granular fertilizer	Target n/a Actual 0.00 lbs/a
	NH3	Target n/a Actual 0.00 lbs/a
	liquid	Target n/a Actual 0.00 gal/a

Material details, page 1

Tap the material to see the first details view of the material.

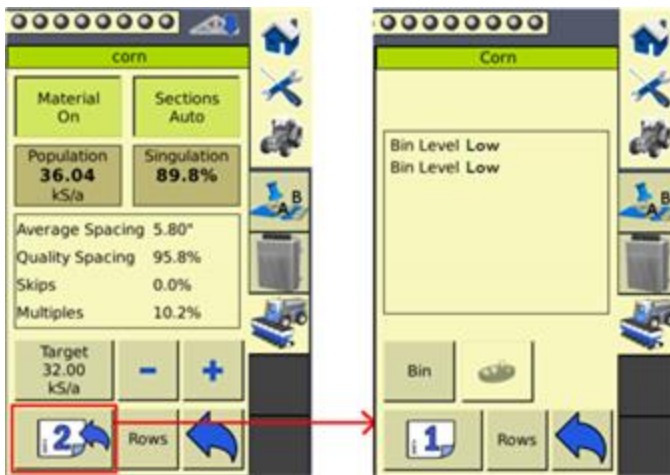

Page 1 Buttons	Tap to...
Material On	Turn the material on or off.
Sections Auto	Turn automatic section control on or off.
Target	Select if Target 1 or Target 2 is shown, or to select Manual to turn the Target rate off. Tap - to decrease the Target rate by 1. Tap + to increase the Target rate by 1.
	To see the second detailed view of the material.
Rows	To go to the Row detail view (page 392).

Material details, page 2

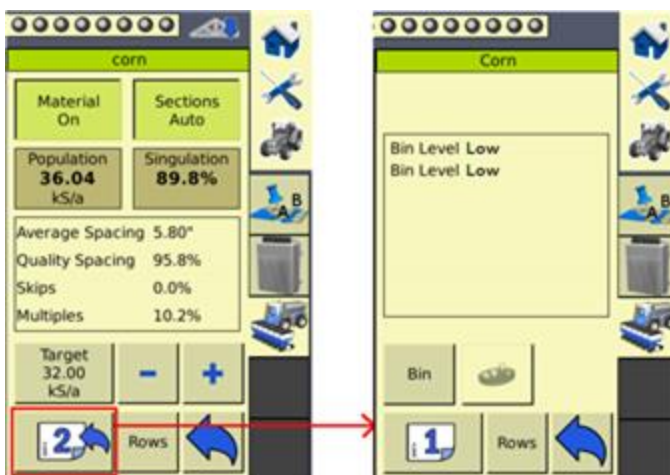

Depending on the material, the following buttons display on the second page of the material details view.

Page 2 Buttons	Tap to...
Bin	Go to the <i>Virtual Bin / Tank Setup</i> screen where you can adjust the bin settings.
Seed Disc	Fill the seed disk.
Arm Pump	Enable Field-IQ to control the pump.
Gate Setup	Go to the <i>Gate Setup</i> screen.
Density	Go to the <i>Density</i> screen where you can enter the density of the current product.
	Return to the previous detailed view .
Rows	To go to the Row detail view (page 392) .

Row detail view

To see detailed information on the rows, tap **Rows**.



The color of the row numbers indicate how far off target the rows are applying.

- Green: Rows are applying on target.
- Red: Rows are applying off target.
- Black: Rows have been manually turned off.
- White: Rows have been turned off automatically by the system.

To view more rows, tap the arrow buttons .

To return to the previous view, tap .

Section control view

To open the section control view on the *Run* screen, tap  in the lower left corner of the screen.

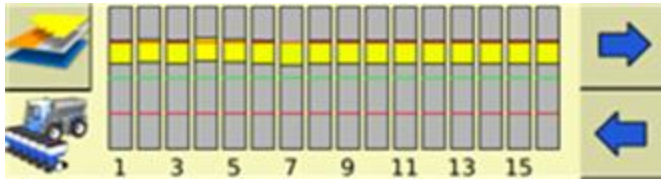

The section control view shows the engage status of each row on the implement:

- Green: Engaged
- Gray: Section closed due to overlap
- Red: Not engaged or section manually turned off

Field-IQ master switch box functions

Note – All systems must have a Field-IQ master switch box.



Item	Setting	Explanation
1	Increment/ decrement switch	Increases or decreases the applied amount by a set amount (the amount is set in the <i>Setup</i> screen, Rate tab).
2	Rate switch	Preset Rate 1, preset Rate 2, or Manual rate.
3	LED indicator	<ul style="list-style-type: none"> Red: Unit is powered but not communicating with the FM-1000 Plus application. Green: Unit is powered and communicating with the FM-1000 Plus application. Yellow: Unit is initializing communications with the FM-1000 Plus application.
4	Automatic/Manual section switch	<p>You can switch from Automatic to Manual mode while traveling.</p> <ul style="list-style-type: none"> Automatic mode: The FM-1000 Plus application automatically opens and closes sections when entering areas of overlap, non-apply zones, or crossing boundaries. Manual mode: The sections are controlled by the user using the Field-IQ system.
5	Master switch	<ul style="list-style-type: none"> 5a: Jump start position. The same functions as in Master On are active, plus the system is overridden to use a preset control speed (the speed is set in the <i>Setup</i> screen, Override tab). 5b: On position. The sections and rate are ready to be commanded by the FM-1000 Plus application. 5c: Off position. Sections are closed and rate is set to zero.

Item	Setting	Explanation
		When you use Lock in Last Position, the valve is locked and the rate is controlled by an auxiliary master valve or section.

Field-IQ 12-section switch box (optional)



Only one section switch box can be used on each system. Each section switch is automatically assigned to the corresponding section. The sections are read from left to right. For example, switch 1 assigns to the section furthest on the left when standing behind the implement. For more information, see the *Hardware* tab in *Setup* screen of Field-IQ.

The section switches have different functions, depending upon the status of the master Automatic/Manual section control switch on the master switch box.

Automatic section control

When the Automatic/Manual section control switch is in the *Automatic* position, if the section switch is in the:

- On/up position: The section(s) assigned to it are commanded automatically by the FM-1000 Plus application.
- Off/down position: The section(s) assigned to it are commanded to be off.

Manual section control

When the Automatic/Manual section control switch is in the **Manual** position, if the section switch is in the:

- On/up position: The section(s) assigned to it are commanded to be on. This overrides the FM-1000 Plus application and coverage logging is ignored.
- Off/down position: The section(s) assigned to it are commanded to be off. This overrides the FM-1000 Plus application and coverage logging is ignored.

LED status indicators

The LED indicators on the section switch box are:

- Green: Unit is powered and is communicating with the display.
- Yellow: Unit is initializing communications with the display.
- Red: Unit is powered but not communicating with the display.

Material assignment

To change materials quickly and easily:

1. At the *Material Assignment* screen, tap the material to change. A list of available materials displays.
2. Select the material you want from the list and tap **OK**.



Material assignment

Use the *Material Assignment* option to quickly and easily change materials. The location name you set up displays (for example, Hoppers) and the button shows the current material name.

Tap the button to see a list of the same type of materials. To change the material type, select the required material from the list, and then tap **OK**.

Enable sections



To enable sections:

1. At the *Home* screen, tap .
2. At the *Configuration* screen, tap  Field-IQ and then tap **Diagnostics**.
3. At the *Field-IQ Diagnostics* screen on the *Operations* tab, tap the section you want to enable.



Enter values manually



To enter values manually:

1. At the *Home* screen, tap .
2. At the *Configuration* screen, tap  Field-IQ and then tap **Diagnostics**.
3. At the *Field-IQ Diagnostics* screen on the *Operations* tab, you can enter values manually for:

Setting	Explanation
Tank Level	Enter a value or tap Refill Tank .
Target Rate	Use the buttons to decrease or increase the required rate for the rate switch.
Speed	Use the buttons to decrease or increase speed.
Aggressiveness	Check the value for Applied Rate. Increase or decrease aggressiveness to achieve the rate you want.

Test optional switch box

To test the optional switch box:

1. At the *Home* screen, tap .
2. At the *Configuration* screen, tap  Field-IQ and then tap **Diagnostics**.
3. At the *Field-IQ Diagnostics* screen on the Operations tab:
 - a. Flip each switch in the section switch box.
 - b. The section it is assigned to displays as gray.

Prescriptions

To send target rates to the variable controller, you can define variable rate controller setup data and [load prescription files](#) that define the rates to be applied in different areas of the field. This information is used to send target rates to the variable rate controller. Applied rates are received from the controller, and both target and applied rates display on the screen. In addition, you can log data relating to the variable rate application to the hard drive.

After you create the prescription, store either the three prescription files in ESRI shape-file format or the single .gdx file in the \AgGPS\Prescriptions\ folder. Then, when you are within the proximity criteria, the prescription is available to load.

If you use complex contoured prescriptions, loading the prescriptions can take some time. The FM-1000 Plus application shows progress bars while it loads and converts prescriptions.

You can configure the status sliders on the main navigation screen (the Run screen) to show the target rate specified in the prescription file, and the applied rates returned from the controller for the active channel.

When a field is open, a prescription is loaded, and a controller is connected, the target rates (read from the prescription) and applied rates (received from the controller) can be shown in the status text items. For more information, see [Status items \(page 79\)](#).

The FM-1000 Plus application can load prescription files created by a Geographic Information System (GIS). The method you use to create the prescription depends on which GIS package you use.

When you map a new field or select an existing field, you can also select any shapefile (.shp) or AgInfo GDX (.gdx) prescription file created in AgInfo version 3.5.44.0 or later, that is within these limits:

For...	Prescriptions must...
Boundary	Overlap the field boundary
AB Line	Overlap the AB Line
Proximity	Be within 1 km of the field

If you load a shapefile prescription, select the rate column.



CAUTION – When you select a shapefile prescription, the applied rate will be incorrect if you choose the wrong column when using a variable rate controller.

Load prescription file

A prescription works only when the Field-IQ rate selection switch is in the Rate 1 position.

Rate Switch Position	Increment/Decrement Switch Status
Rate 1	Disabled
Rate 2	Enabled

To load a prescription file:

1. Map a new field or select an existing field. The FM-1000 Plus application lists the prescription files within the specified limits. If there are many prescriptions on the hard drive, this can take several seconds, and a progress bar displays.

If any prescription files are within the specified limits, the *Select Prescription* screen displays.

2. From the Available Prescriptions list, select a prescription file.

Note – If an AgInfo GDX prescription has an incorrect format, it will not display in the Available Prescriptions list.

- If you select a shapefile prescription, select the correct prescription rate column.

Note – When you select a shapefile prescription, if you choose the wrong column when using a variable rate controller, the applied rate will be incorrect.

- If you select an AgInfo GDX prescription, the Rate Column box does not appear.

3. From the Prescription Scale Factor, select the scale factor for the units used in the prescription file.
4. Set the [lead time](#).
5. From the When off prescription use list, select the target rate for when you are outside the area that is covered by the prescription file. See [Prescriptions \(page 398\)](#).
6. Tap **OK** to load the prescription file.

Lead time

Lead-time is the average time required by the controller before it can react to a requested rate change. Define the lead time in the *Select Prescription* screen. For example, a value of 5.0 means that, on average, it takes the controller around five seconds to change from one rate to a new rate.

The direction and speed of the vehicle are combined with the lead time to project a future position of the vehicle. The target rate at this projected position is sent to the variable rate controller, giving the controller time to reach the required rate at approximately the same time that the vehicle arrives at the projected position.

You must choose an appropriate lead time. This depends on the:

- Controller type and configuration
- Type of materials being applied
- Nature and specifications of the delivery equipment

Control outside the prescription area

When the vehicle moves outside the area covered by the prescription file, no target rate is available. There are three options for controlling the output rate:

- Continue to use the last rate being output when the vehicle moves off the prescription
- Use a default rate
- Use a zero rate

Specify the required option in the *Select Prescription* screen.

You can now select prescriptions even when the vehicle is a great distance away from the field, which enables you to load a prescription before driving to the field.

Manual guidance operation

When you use the Manual Guidance option, you must steer the vehicle manually while you watch the virtual lightbar for guidance.

The **Run** screen looks similar to when the Autopilot option is installed, except that:

- There is no Autopilot tab on the right
- There is no **Engage** button





You can still tap  to open the Mapping Guidance panel and add field features or create guidance lines.

Autopilot system operation

To engage the Autopilot system, you must have:

- Have a field open in the *Run* screen
- Have an existing pattern you are using
- The vehicle within the distance of the guidance line set in the Engage tab. See [Engage settings for Autopilot system \(page 165\)](#).

When you are using Autopilot, you use the **Engage** button to automatically steer on the guidance line. The Engage button can indicate status and, in some cases, also control the Autopilot system.

Indicator/Button	Explanation	Tap to...
 Ready to Engage (yellow)	The vehicle is close enough to the guidance line to engage on it.	Engage on the guidance line.
 Engaged (green)	The vehicle is engaged on the guidance line.	Stop engaging on the guidance line.
 Not Ready to Engage (red)	The vehicle is not ready to engage on the line because the guidance line is too far from the vehicle.	N/A. You cannot tap this button. It is an indicator only.
 Auto steering not allowed (red)	Automatic steering is not allowed due to how it has been set up.	N/A. You cannot tap this button. It is an indicator only.

You can also [Adjust Autopilot guidance \(page 403\)](#) settings during operations in the field.

Adjust Autopilot guidance

At the *Run* screen, tap . The Autopilot panel displays.

Setting	Explanation
Nudge	<p>The guidance line can move off target due to either:</p> <ul style="list-style-type: none"> • GPS position drift after pausing or turning off the system • GPS satellite constellation changes as you drive in the field <p>Use the < and > buttons to move the line in a perpendicular direction (left or right).</p> <p>To set the increment for this setting, see Steering settings for Autopilot system (page 166).</p>
Trim	<p>Trim replaces Nudge when you are using RTK corrections.</p> <p>The vehicle can steer offline as a result of uneven drag on the vehicle from an unbalanced implement or from soil conditions.</p> <p>Use the < and > buttons to move the vehicle in a perpendicular direction (left or right) of the line you are currently engaged on.</p> <p>To set the increment for this setting, see Steering settings for Autopilot system (page 166).</p>
Online Aggr	<p>Aggressiveness is the measure of how strongly the system makes steering changes.</p> <p>Use the - and + buttons to adjust how aggressively the vehicle moves to the guidance line. A setting that is:</p> <ul style="list-style-type: none"> • Higher brings the vehicle back online faster, but may cause tight oscillations about the line • Lower: Brings the vehicle back online more slowly, but can avoid overshoot <p>Note – The default aggressiveness setting is 100%.</p>

Disengage Autopilot system

The Autopilot system can be disengaged [automatically](#) and [manually](#).

Automatic disengagement

The Autopilot system disengages automatically when:

- The vehicle is outside the allowed distance from the guidance line set up in the Engage tab. See [Engage settings for Autopilot system \(page 165\)](#).
- The system is paused.
- GPS positions are lost.

Manual disengagement

To manually disengage the system, you can:

- Tap  on the screen.
- Turn the steering wheel to override the electric motor.

When you turn the steering wheel manually, the Autopilot system disengages. It is recommended that you check this setting before you begin using the system in a new installation. To do so:

- a. Engage on a line.
- b. Turn the wheel until Autopilot disengages.

To make adjustments to the amount of force required to disengage the system using the steering wheel, see [Automated Deadzone calibration \(page 173\)](#).

NextSwath operation

Note – For NextSwath setup, see [NextSwath settings \(page 189\)](#).



WARNING – Installers, technicians, and operators must verify that the Autopilot function (line acquisition and online guidance) is in good, safe, working order before the operator uses NextSwath.

The optional NextSwath feature/plugin works with Autopilot to enable you to:

- Use automatic turns between swaths (see [Automatic turn \(page 406\)](#))
- Tap the Turn Now button to begin an automatic turn prior to or after the turn point (see [Start turn now \(page 411\)](#))
- Extend the point for the automatic turn to compensate for larger implements when you enable TrueSwath (see [TrueSwath operation \(page 413\)](#))
- Use automated implement functions and reminders to occur before you begin or end a swath (see [Using automated headlands management \(page 415\)](#))

Automatic turn

Note – Only use NextSwath for straight AB and A+ lines, and headland infill patterns. NextSwath cannot be used with curve, pivot, or FreeForm patterns, feature line guidance, TrueTracker, FieldLevel II, or RG-100 Row Guidance systems.



WARNING – A trained and qualified operator must be at the controls of the vehicle at all times, and be ready to safely take over controls of the system at anytime. NextSwath is not a safety aid nor a replacement for a skilled operator.



WARNING – NextSwath cannot avoid obstacles. The operator is solely responsible for avoiding obstacles.







WARNING – Interaction with and avoidance of boundaries is solely the operator's responsibility. While NextSwath can use field boundaries for a reference point for turn start points, the trained and qualified operator is responsible for determining offsets from field boundaries. NextSwath does not calculate distance of the vehicle or machinery from the boundary during the turn.

Automatic turn points are calculated from one of these:



- A headland infill boundary. see Shorten or Extend Swath setting in [Automatic turn settings \(page 190\)](#).
- Whether the turn point is inside or outside a productive boundary (if you have a boundary without headlands). see Turn Point Inside/Outside Boundary setting in [Automatic turn settings \(page 190\)](#).
- The A and B points for a line in a field without a boundary

The basic steps to use the NextSwath automatic turn are:

1. Enter the field.
2. At the *Run* screen, tap  to go to the NextSwath panel.
3. Check the NextSwath checkbox  to enable the NextSwath capability.

Note – Each time you enter the field or change to a different guidance line/pattern, you must enable NextSwath before you can use it.
4. When the system displays the liability warning, read the warning and accept it if you understand it and are ready to accept it.
5. Tap  (yellow) to engage on a guidance line. When you are engaged, the engage button will change to green , indicating you are engaged on the line and the Autopilot system is now steering the vehicle. When you reach the location where the end of row warning message

displays, the system:

- Checks the **Enable Turn**  checkbox which indicates automatic turn is enabled
 - Changes the turn button from red  to yellow 
 - Displays buttons that enable you to cancel the automatic turn or confirm you want the automatic turn (If you are not on the NextSwath panel, the Adjust button also displays).
6. Use the swath direction controls to choose the direction you want the vehicle to automatically turn toward (in reference to the forward direction of travel). Tap either the left < or right > direction button. With each tap of the direction button, the amount of swaths (shown by the swath number) you will move to during the turn increases. If viewable, the selected swath to change to will be highlighted in green on the *Run* screen. See [Adjust direction and swath number \(page 410\)](#). The system displays a yellow line indicating the length of the automatic turn.

Note – You can travel up to 10 swaths over or a maximum of 500 feet/150 meters.

This graphic indicates you are moving one swath and are turning left.

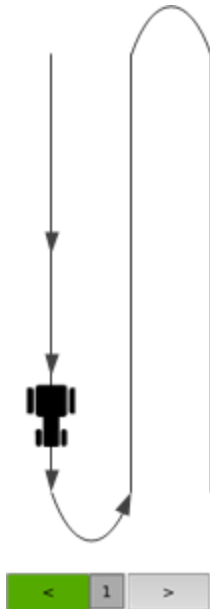

Note – To clear the swath number, uncheck and recheck **Enable Turn**.

7. If you want the automatic turn to occur, tap **Accept Auto Turn**. The system:
- Displays information about the turn, including how far away from the turn point you are
 - Changes the turn button to green 
 - Begins the turn when your vehicle reaches the turn point, and completes the turn

Note – If you are traveling too fast for the system to complete the turn, the automatic turn will not occur.

Note – The automatic turn shape and speed will occur based on how you have set up auto turn. See [NextSwath settings \(page 189\)](#).

After the turn is completed, the system disables the **Enable Turn** checkbox.

8. If you want to cancel the automatic turn, tap **Cancel Auto Turn**. The system cancels the automatic turn and the turn button changes to yellow . Also see [Start turn now \(page 411\)](#).
9. As you drive on the next swath, when you reach the location where the end of row warning message displays, the system:

- Enables and checks the **Enable Turn**  checkbox
- Enables the swath chooser in the opposite direction, as shown in this graphic:

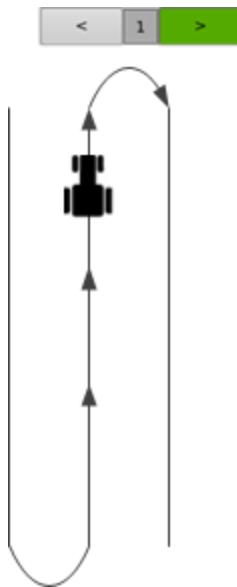

Follow steps 6 through 8 as appropriate.



Tip – You can set up status items to show the length of the swath (Swath Length) and the calculated distance to the end of the swath (Along Track Error). See [Status items \(page 79\)](#).

Auto turn cancel



WARNING – A trained and qualified operator must be at the controls of the vehicle at all times, and be ready to safely take over controls of the system at anytime. NextSwath is not a safety aid nor a replacement for a skilled operator.



WARNING – NextSwath cannot avoid obstacles. The operator is solely responsible for avoiding obstacles.

When you want to cancel an automatic turn:

1. When you reach the location where the end of row warning message displays, the system displays controls that enable you to confirm or cancel the automatic turn.
2. Tap **Cancel Auto Turn**. The system:
 - Cancels the automatic turn
 - Changes the turn button to yellow 

Adjust direction and swath number



WARNING – Interaction with and avoidance of boundaries is solely the operator's responsibility. While NextSwath can use field boundaries for a reference point for turn start points, the trained and qualified operator is responsible for determining offsets from field boundaries. NextSwath does not calculate distance of the vehicle or machinery from the boundary during the turn.



WARNING – A trained and qualified operator must be at the controls of the vehicle at all times, and be ready to safely take over controls of the system at anytime. NextSwath is not a safety aid nor a replacement for a skilled operator.



WARNING – NextSwath cannot avoid obstacles. The operator is solely responsible for avoiding obstacles.

If you are not at the NextSwath panel while engaged and you want to change the number of swaths to skip or change the direction of the upcoming automatic turn:

1. When you reach the point when the end of row warning displays, the system displays the **Adjust** button as well as the options to accept or cancel the automatic turn. Tap **Adjust** to quickly return to the NextSwath panel.
2. Make the appropriate changes to the direction and swath number.



Start turn now



WARNING – Interaction with and avoidance of boundaries is solely the operator's responsibility. While NextSwath can use field boundaries for a reference point for turn start points, the trained and qualified operator is responsible for determining offsets from field boundaries. NextSwath does not calculate distance of the vehicle or machinery from the boundary during the turn.





WARNING – NextSwath cannot avoid obstacles. The operator is solely responsible for avoiding obstacles.



WARNING – A trained and qualified operator must be at the controls of the vehicle at all times, and be ready to safely take over controls of the system at anytime. NextSwath is not a safety aid nor a replacement for a skilled operator.

When you want to start an automatic turn instead of having the system start it, the steps to begin the automatic turn depend on where your vehicle is in relation to the point for the end-of-row turn warning or the turn point. The turn button indicates this by changing colors.

Yellow turn button

If the turn button is yellow  and you want to begin an automatic turn, tap the turn button  (yellow).



The system will:

- Change the turn button to green 
- Immediately begin and complete the automatic turn

If you have programmed automated headlands management events for use, also see [Using automated headlands management \(page 415\)](#).

Red turn button

If the turn button is red  and you want to begin an automatic turn:

1. Check **Enable Turn** .
2. Choose the direction and number of swaths to move to. The system changes the turn button to yellow .
3. Tap the yellow  turn button. The vehicle will begin and complete the automatic turn.

Green turn button

If the turn button is green, you are already in the process of an automatic turn. To cancel the automatic turn, you can do any of these:

- Tap the turn button again.
- Grab the wheel.
- Tap  to disengage the Autopilot system.

The system stops the automatic turn and changes the turn button to yellow .

TrueSwath operation



WARNING – A trained and qualified operator must be at the controls of the vehicle at all times, and be ready to safely take over controls of the system at anytime. NextSwath is not a safety aid nor a replacement for a skilled operator.



WARNING – Interaction with and avoidance of boundaries is solely the operator's responsibility. While NextSwath can use field boundaries for a reference point for turn start points, the trained and qualified operator is responsible for determining offsets from field boundaries. NextSwath does not calculate distance of the vehicle or machinery from the boundary during the turn.



WARNING – NextSwath cannot avoid obstacles. The operator is solely responsible for avoiding obstacles.

Note – You can only use TrueSwath with drawn implements. Rigid mounted / 3-point implements cannot use TrueSwath.

Without TrueSwath, the implement lags behind the vehicle during line acquisition, preventing proper coverage.

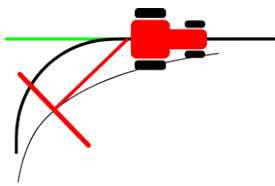

TrueSwath optimizes line acquisition and end-of-row turns for pulled implements. You can use TrueSwath whether or not you are using automated turns. (To use TrueSwath for automated turns, you must have NextSwath enabled.)

Tap the TrueSwath checkbox to enable the feature. On the display for either an end-of-row turn or acquiring the line, a green line shows the path for the vehicle and a yellow line the implement path.

If you use TrueSwath for an automatic turn, the turn point will be extended to allow the implement to reach the turn point before the turn is started. The vehicle will purposely drive beyond the guidance line to pull the implement on the guidance line.

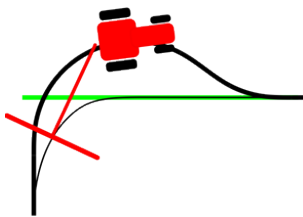

The path planned for the implement is based on the values you enter in the Measurements tab (under Autopilot setup) for:

- Vehicle control point to tow hitch (see [Measurements for NextSwath \(page 167\)](#))
- Hitch to ground contact point

Adjust these measurements to improve the performance of TrueSwath. See [Measurements for NextSwath \(page 167\)](#).

Using automated headlands management

Note – To set up the capability for automated functions in the FM-1000 Plus application, see [Automated headlands management settings \(page 194\)](#).



WARNING – Do not use automated implement functions to: 1) control hazardous materials (including NH3) or 2) operate implements near ground laborers. Failure to follow these restrictions could result in serious injury or death.

In the *Run* screen, before you have reached the point for the end-of-row turn warning, tap either or both:

- The checkbox next to the Swath Start Events button (the button on the left) to enable the sequence at the start of the swath
- The checkbox next to the Swath End Events button (the button on the right) to enable the sequence at the end of the swath

The vehicle will perform the end and/or begin sequence of automated operations you have programmed in your vehicle. The FM-1000 Plus application will provide any sound or text alerts you have set up.

Using turn now

If you choose to turn the vehicle prior to or after the point of the end-of-row turn warning:

- Follow the appropriate steps in [Start turn now \(page 411\)](#)
- After you tap the yellow turn button , the system begins the first automated event or reminder you have programmed and provides a countdown to the turn.

EZ-Pilot system operation



WARNING – Many large and sudden changes in satellite geometry caused by blocked satellites can cause significant position shifts. If operating under these conditions, auto-guidance systems can react abruptly. To avoid possible personal injury or damage to property under these conditions, disable the auto-guidance system and take manual control of the vehicle until conditions have cleared.





To engage the EZ-Pilot system, you must have:

- Have an open field in the Run screen
- Have an existing pattern you are using
- The vehicle within the engage distance set in the Engage tab. See [Engage settings for EZ-Pilot system \(page 201\)](#).

The Engage button on the screen can indicate status and, in some cases, also control the EZ-Pilot system.

When you are using EZ-Pilot, to automatically steer on the guidance line you can:

- Tap  (yellow) on the screen
- Press the **Engage** button on the EZ-Remote joystick
- Use an external foot or rocker switch

Indicator/Button	Explanation	Tap to...
 Ready to Engage (yellow)	The vehicle is close enough to the guidance line to engage on it.	Engage on the guidance line.
 Engaged (green)	The vehicle is engaged on the guidance line.	Stop engaging on the guidance line.
 Not Ready to Engage (red)	The vehicle is not ready to engage on the line because the guidance line is too far from the vehicle.	N/A. You cannot tap this button. It is an indicator only.
 Auto steering not allowed (red)	Automatic steering is not allowed due to how it has been set up.	N/A. You cannot tap this button. It is an indicator only.

You can also [Adjust EZ-Pilot guidance \(page 418\)](#) settings during operations in the field.

Disengage EZ-Pilot system

The EZ-Pilot system can be disengaged [automatically](#) and [manually](#).

Automatic disengagement

The EZ-Pilot system disengages automatically when:

- The vehicle is outside the engage distance set up in the Engage tab. See [Engage settings for EZ-Pilot system \(page 201\)](#).
- The system is paused.
- GPS positions are lost.
- The Minimum Fix Quality setting is set to a high accuracy correction method and the system receives low accuracy positions (such as no corrections).

Manual disengagement

To manually disengage the system, you can:

- Tap  (green) on the screen.
- Press the **Engage** button on the optional remote control.
- Turn the steering wheel to override the electric motor.

When you turn the steering wheel manually, the EZ-Pilot system disengages. It is recommended that you check this setting before you begin using the system in a new installation. To do so:

- a. Engage on a line.
- b. Turn the wheel until EZ-Pilot disengages.

To make adjustments to the amount of force required to disengage the system using the steering wheel, see [Steering performance calibration \(page 203\)](#).

Adjust EZ-Pilot guidance



WARNING – Many large and sudden changes in satellite geometry caused by blocked satellites can cause significant position shifts. If operating under these conditions, auto-guidance systems can react abruptly. To avoid possible personal injury or damage to property under these conditions, disable the auto-guidance system and take manual control of the vehicle until conditions have cleared.

At the *Run* screen, tap . The EZ-Pilot panel displays.

Setting	Explanation
Nudge	<p>The guidance line can move off target due to either:</p> <ul style="list-style-type: none"> • GPS position drift after pausing or turning off the system • GPS satellite constellation changes as you drive in the field <p>Use the < and > buttons to move the line in a perpendicular direction (left or right).</p> <p>To set the increment for this setting, see Steering settings for EZ-Pilot system (page 200).</p>
Trim	<p>Trim replaces Nudge when you are using RTK corrections.</p> <p>The vehicle can steer offline as a result of uneven drag on the vehicle from an unbalanced implement or from soil conditions.</p> <p>Use the < and > buttons to move the vehicle in a perpendicular direction (left or right) of the line you are currently engaged on.</p> <p>To set the increment for this setting, see Steering settings for TrueTracker system (page 291).</p>
Online Aggr	<p>Aggressiveness is the measure of how strongly the system makes steering changes.</p> <p>Use the - and + buttons to adjust how aggressively the vehicle moves to the guidance line.</p> <p>A setting that is:</p> <ul style="list-style-type: none"> • Higher brings the vehicle back online faster, but may cause tight oscillations about the line • Lower: Brings the vehicle back online more slowly, but can avoid overshoot <p>Note – The default aggressiveness setting is 100%.</p>

EZ-Steer system operation



WARNING – Many large and sudden changes in satellite geometry caused by blocked satellites can cause significant position shifts. If operating under these conditions, auto-guidance systems can react abruptly. To avoid possible personal injury or damage to property under these conditions, disable the auto-guidance system and take manual control of the vehicle until conditions have cleared.





To engage the EZ-Steer system, you must have:

- Have a field open in the *Run* screen
- Have an existing pattern you are using
- The vehicle within the engage distance set in the Engage Options tab. See [Engage settings for EZ-Steer \(page 206\)](#).

The **Engage** button on the screen can indicate status and, in some cases, also control the EZ-Steer system.

When you are using EZ-Steer, to automatically steer on the guidance line you can:

- Tap  (yellow) on the screen.
- Press the optional remote engage foot pedal.

Indicator/Button	Explanation	Tap to...
 Ready to Engage (yellow)	The vehicle is close enough to the guidance line to engage on it.	Engage on the guidance line.
 Engaged (green)	The vehicle is engaged on the guidance line.	Stop engaging on the guidance line.
 Not Ready to Engage (red)	The vehicle is not ready to engage on the line because the guidance line is too far from the vehicle.	N/A. You cannot tap this button. It is an indicator only.
 Auto steering not allowed (red)	Automatic steering is not allowed due to how it has been set up.	N/A. You cannot tap this button. It is an indicator only.

You can also [Adjust EZ-Steer guidance \(page 421\)](#) settings during operations in the field.

Disengage EZ-Steer system

The EZ-Steer system can be disengaged [automatically](#) and [manually](#).

Automatic disengagement

The EZ-Steer system disengages automatically when:

- The vehicle is outside the engage distance set up in the Engage tab. See [Engage settings for EZ-Steer \(page 206\)](#).
- The system is paused.
- GPS positions are lost.
- The Minimum Fix Quality setting is set to a high accuracy correction method and the system receives low accuracy positions (such as no corrections).

Manual disengagement

To manually disengage the system, you can:

- Tap  (green) on the screen.
- Press the **Engage** button on the optional remote control.
- Turn the steering wheel to override the electric motor.

When you turn the steering wheel manually, the EZ-Steer system disengages. It is recommended that you check this setting before you begin using the system in a new installation. To do so:

- a. Engage on a line.
- b. Turn the wheel until EZ-Pilot disengages.

To make adjustments to the amount of force required to disengage the system using the steering wheel, see [Steering performance calibration \(page 203\)](#).

When the system is not in use, hinge the motor away from the steering wheel and then secure it with the lock pin.

Adjust EZ-Steer guidance



WARNING – Many large and sudden changes in satellite geometry caused by blocked satellites can cause significant position shifts. If operating under these conditions, auto-guidance systems can react abruptly. To avoid possible personal injury or damage to property under these conditions, disable the auto-guidance system and take manual control of the vehicle until conditions have cleared.

At the *Run* screen, tap . The EZ-Steer panel displays.

Setting	Explanation
Nudge	<p>The guidance line can move off target due to either:</p> <ul style="list-style-type: none"> • GPS position drift after pausing or turning off the system • GPS satellite constellation changes as you drive in the field <p>Use the < and > buttons to move the line in a perpendicular direction (left or right).</p> <p>To set the increment for this setting, see Steering settings for EZ-Pilot system (page 200).</p>
Trim	<p>Trim replaces Nudge when you are using RTK corrections.</p> <p>The vehicle can steer offline as a result of uneven drag on the vehicle from an unbalanced implement or from soil conditions.</p> <p>Use the < and > buttons to move the vehicle in a perpendicular direction (left or right) of the line you are currently engaged on.</p> <p>To set the increment for this setting, see Steering settings for EZ-Pilot system (page 200).</p>
Online Aggr	<p>Aggressiveness is the measure of how strongly the system makes steering changes.</p> <p>Use the - and + buttons to adjust how aggressively the vehicle moves to the guidance line.</p> <p>A setting that is:</p> <ul style="list-style-type: none"> • Higher brings the vehicle back online faster, but may cause tight oscillations about the line • Lower: Brings the vehicle back online more slowly, but can avoid overshoot <p>Note – The default aggressiveness setting is 100%.</p>

GreenSeeker operation

The GreenSeeker system requires either of these to be activated for use:

- Field-IQ system
- Serial Rate Control system

Prior to using the GreenSeeker system:

1. Collect or input reference strip data.
2. Calibrate the system with either:
 - The boom mounted sensors on the RT200
 - The GreenSeeker handheld sensor
3. If you are using the RT200 interface module for variable rate control, set up the application equipment and rate controller to match the expected delivery rate commands.

Best practice

To ensure best performance from the GreenSeeker variable application system:

- Rinse the boom at the end of every day. Do this to keep the system clean and remove to any corrosive materials. Doing so will greatly extend the life of your machine.
- Do not use high pressure spray on the sensors when rinsing the machine. Even though all of the connectors and modules are fully sealed, there is the potential for leakage caused by the pressurized stream.
- Every time the spray tank is filled, take a soft cloth and wipe the lenses of the sensors. Try to check sensors at least once a day during full time operation.
- Be more aware of cleaning the sensors directly behind the machine.
- If you do not have ground protection devices on the boom (such as gauge wheels or skids) take extra care to not run the boom into the ground. Also, be aware of sensor vulnerability to stationary structures in the field.
- Sensors are usually mounted on the front of the boom and do not have rigid protection.
- Sensors should be re-calibrated after approximately 1000 hours of use due to possible changes in light output. This is generally done at the factory, or authorized service center.
- Sensors have an optimum operating range of 32" - 48" above the crop canopy. 38" is the optimum height, and must be measured from the top of the crop to the rectangular LED window of the sensor.
- Make sure all wiring harness components remain fastened to the boom as to not obstruct the view of the sensors and are free of any pinch points from boom folding and movement.

Variable rate setup

To set up variable rate application on the FM-1000 Plus application:

1. Power up the RT200 interface module and the rate controller (if required).

When the RT200 interface module is first powered on:

- a. The module's green power LED will blink three times accompanied by three beeps.
- b. The status LED will blink in time with each transmission of sensor data over the CAN bus.

Expect to see a brief green flash, followed by a red flash at the I/M message rate (typically at 0.5sec). This indicates that data from the left (green flash) and right (red flash) CAN ports is being transmitted.

2. Activate GreenSeeker for use. See [Activate features/plugins for use \(page 60\)](#).

3. At the *Home* screen, tap  .

4. At the *Configuration Selection* screen, tap **OK**.

5. At the *Field Selection* screen, load the field to be sprayed.

Create a custom table

Historical knowledge about the crop enables growers or crop consultants to determine different crop input requirements based upon biomass/size of the crop/plant. An example of this type of use would be variable rate application of:

- Defoliant in cotton
- Desiccant in potatoes

For these cases, the field is scouted (field calibrated) to determine areas of the field that require different rates of defoliant.

To obtain the NDVI values in representative areas of the field, you can use either:

- The RT200 system
- A GreenSeeker handheld

Using this data, you can create a table with NDVI values corresponding to application rates.

To create a custom table:

1. At the *GreenSeeker Calibration* screen, tap the *Algorithm* tab.
2. From the *Formula* list, select either:
 Custom Table: Manually enter NDVI calibration values (go to step 4)

Auto Calibration: The system automatically enters NDVI calibration values from the Calibration step by transferring the Maximum, Average, and Minimum NDVI values into rows two, three, and four respectively.

3. Tap the Number Of Rows entry box, enter a value and tap **OK**.

The number of available NDVI and Rate values are dictated by the value entered in the Number Of Rows entry box.

Typically the number of rows for the custom table are two more than the number of filed calibration areas sampled. This allows for starting at zero and ending at .99 NDVI.

4. Tap an NDVI entry box to enter a custom value.
5. Tap **OK**.
6. Tap a corresponding Rate entry box to enter a custom value.
7. Tap **OK**.
8. Select the Output tab.
9. From the Material Type list, select either Granular OR Liquid.
10. Tap **OK**.

Calibrate GreenSeeker

In the GreenSeeker panel on the *Run* screen, the controls displayed depend on what you previously selected (for example, a crop algorithm or a custom table).

When you first open a new job or event and a crop algorithm has been previously used or selected, the Calibration Required message displays.

If you want to use a custom table, but see the Calibration Required message, tap **Edit**. See [Create a custom table \(page 423\)](#).

Note – If a custom table has been previously selected, the *Calibration Required* message will not display.

Calibration steps

1. At the *Run* screen, tap . The GreenSeeker panel opens.
2. Tap **Calibrate**.
3. The GreenSeeker panel displays:
 - The buttons **Ref**, **Non-Ref** and **Done**
 - NDVI bar graph showing the real-time combined average NDVI from the RT200 module
4. Position the vehicle at the reference locations.
5. To record NDVI data from:

- The reference strip: Tap **Ref**, drive the reference strip and then tap **Ref** again to end recording.
- The non-reference strip: Tap **Non-Ref**, drive the nonreference strip and then tap **Non-Ref** again to end recording.

Note – As the NDVI is collected, the data displays. Keep the vehicle moving as you collect the data. If you stop in one location, this will affect the average values. The **Ref** and **Non-Ref** buttons change to a lighter color when selected or active.

6. Tap **Done**. At the *GreenSeeker Calibration* screen on the Calibration panel, values that were collected are displayed.

Setting	Explanation
Maximum	Reference: You can override the existing data and enter new data.
Average	Non-Reference or Reference: You can override the existing data and enter new data.
Minimum	Reference: You can override the existing data and enter new data.
Calibrate	Non-Ref or Reference : Tap to collect fresh data. You will not see the new values until you deselect the button you have tapped.

Note – The reference values for *Maximum*, *Average*, and *Minimum* are also available for the *Auto Calibration* function on the *Algorithm* tab.

7. When you are satisfied with the data on the Calibration tab, select the Algorithm tab.

For Formula, select either:

- An existing formula
- Custom Table to create a new algorithm (see [Create a custom table \(page 423\)](#))

Note – The formula selected for your last job will still be current, so you are often just verifying that the correct formula is being used.

The values to be entered will change based upon the formula selected. Some values (such as Nitrogen Use Efficiency) have default values that are formula specific. You can change any value by tapping the entry box.

Note – You may need to reference the specific algorithms instruction for more detailed explanation of the *CumGDD F*, or similar fields. For example the *CumGDD F* for the corn v1.3 GrtPlns GDD OKState is *Cumulative Growing Degree Days, Base 50F*. For specific algorithm instructions, visit www.GreenSeeker.com.

8. Tap **OK**.
9. Go to the Chart tab and enter the settings.

Setting	Explanation
Limit	Enabled: Disabled:
Max Limit	If necessary, enter a value based on rate controller or application equipment limitations.
Min Limit	If necessary, enter a value based on rate controller or application equipment limitations.

Note – Maximum and minimum settings will limit the rate commands given to the rate controller.

10. Review the application chart for each job to determine the appropriate nozzle selections and/or application equipment settings.
11. Tap **OK**.
12. Tap the Output tab.
13. From the Material Type list, select either Granular OR Liquid.
14. Tap **OK**.

ISOBUS operation

With ISOBUS, you can use the FM-1000 Plus application to control an ISO-certified implement without an additional display. An ISO-certified implement has small computers called electronic control units (ECUs) which send signals to the FM-1000 Plus application. An ISO-certified tractor has a tractor ECU (TECU) installed on it. ECUs on implements enable you to control the operation:





- With the FM-1000 Plus application, using Task Controller (an optional feature). See [Task Controller operation \(page 427\)](#).
- With Virtual Terminal, an on-screen window opens so you can directly access the functions provided by the ECUs. See [Virtual Terminal operation \(page 428\)](#).

Task Controller operation

After you have activated Task Controller,  displays on the *Run* screen.

1. If you are using one of the following models, you must tap the **Start** or **Auto** button in the Virtual Terminal screen before starting section and rate control using Task Controller.
 - a. Tap  to open the Virtual Terminal.
 - b. Tap the appropriate button (**Start** or **Auto**).

Mode	Tap...
Kuhn Moduliner Seed Drill	Auto
Kverneland Exacta TL GEOspread	Start
Rauch/Kuhn AXIS-H-EMC	Start
Rauch/Kuhn AXIS-W	Start
Vicon RO-EDW GEOspread	Start

2. At the *Run* screen, tap  on the right-hand side to display the Task Controller panel.
3. Tap  to begin logging coverage.
4. Tap  on the left-hand side to view the current section control.
5. To switch between the two target rates, tap the appropriate target rate button   on the Task Controller panel.
6. To turn section control on and off, tap the **Section Control On / Off** button.

- When section control is off, use the Virtual Terminal for section control.
- When section control is on, sections will automatically turn off to limit multiple pass coverage.

Virtual Terminal operation

After you have activated Virtual Terminal, the  button displays on the *Run* screen.

To access the *Virtual Terminal* screen:

- From the *Diagnostics* screen (under Configuration)
- By tapping  on the *Run* screen. (This button displays on the *Run* screen after you have activated Virtual Terminal.)

Icon(s) on the left of the screen show the available ECUs. The center area and the buttons on the right of the screen change depending on information provided by the ECU.

Note – *Virtual Terminal screens and functions vary by platform. For more information, refer to the equipment manufacturer's operating instructions.*

Remote Output operation

The FM-1000 Plus application automatically outputs pulses based on the settings in [Remote Output settings \(page 136\)](#) as well as [Line feature settings \(page 152\)](#).

Crossing a line feature operation

Using this option, a pulse is output at any point where the line you are engaged on intersects another line feature that has the remote output option enabled. See [Line feature settings \(page 152\)](#).

You can use this remote output option with AB/A+ lines as well as pivots and curves.

Your screen will show:

- Dots showing additional previous pulses
- A red X indicating where the system will output the next pulse
- **Note** – *The location of the next output may change as accuracy of the calculated position improves.*
- A warning when you near the intersecting line, if you have set up warnings (see [Remote Output settings \(page 136\)](#))

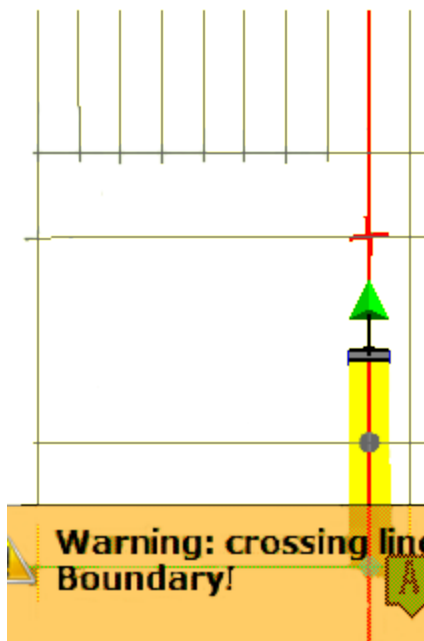

The Remote Output panel shows:

Remote Output Panel	Explanation
Next Output ID	A combination of the next pulse number and the current swath ID). (The pulse number increments with each pulse, and is not related to the swath or vehicle position.)
Current Pass Output	The number of pulses that have been output on the current swath.
Total Outputs	The number of pulses that have been output in the field currently.
Next Output Distance	The distance between the implement and the next point for the system to output a pulse.
Manual Trigger 	Tap this button to manually output a pulse.

Distance-based pulse operation

With this option, pulses are output based on a specific distance you set up in [Remote Output settings \(page 136\)](#). You can use distance-based pulses with straight AB or A+ lines.

Within range limits

When you use remote output with distance-based pulses and you are within the limits of the range set in the Trigger Limits setting, your screen will show:

- The first dot for the first pulse output at the A point for the current swath
- Dots showing additional previous pulses
- A red X indicating where the system will output the next pulse

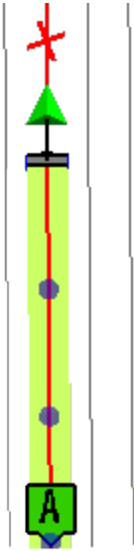

The Remote Output panel shows:

Remote Output Panel	Explanation
Next Output ID	A combination of the next pulse number and the current swath ID.
Current Pass Output	The number of pulses that have been output on the current swath.
Total Outputs	The number of pulses that have been output in the field currently.
Next Output Distance	The distance between the implement and the next point for the system to output a pulse.
Trigger Limits	The maximum number of pulses allowed per swath past the A point. This is set in Remote Output settings (page 136) . You can also

Remote Output Panel	Explanation
	change this during operation. See Change trigger limits during operation (page 432) .
Manual Trigger 	Tap this button to manually output a pulse.

Outside range limits

When the vehicle and implement are outside the range limits:

- There is no red X on the screen.
- On the Remote Output panel, the Next Output ID shows *n/a* for both the next pulse number and the current swath ID.

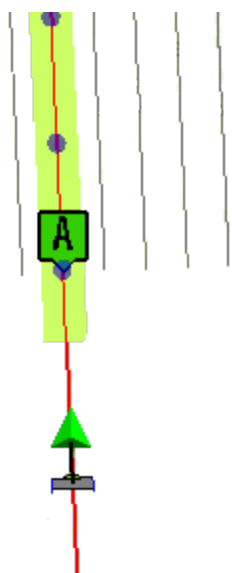

Change trigger limits during operation

To change the maximum number of pulses per swath during operation, tap the button to the left of the label Trigger Limits and enter the new number.

Manually output a pulse

To manually output a pulse, tap .

To set the color of the dot that indicates a manual pulse, see [Remote Output settings \(page 136\)](#).

Row Guidance operation



WARNING – Many large and sudden changes in satellite geometry caused by blocked satellites can cause significant position shifts. If operating under these conditions, auto-guidance systems can react abruptly. To avoid possible personal injury or damage to property under these conditions, disable the auto-guidance system and take manual control of the vehicle until conditions have cleared.

With Row Guidance, the information from existing sensors installed on the combine heads are used to automatically adjust the combine response to changes in the row position.

Row Guidance is used with the Autopilot system to help center the combine on the crop rows when they are not aligned with the guidance line used to plant the crop (caused by planter drift or environmental damage).

Row Guidance enables you to:

- Increase corn yield through reduced ear loss
- Reduce operator fatigue in difficult conditions (such as down corn, curved rows, long passes and other poor visibility conditions)
- Operate effectively in fields that were planted using other steering systems or in areas where the planter drifted

You can operate Row Guidance with:

- Straight lines: You can use either A-B or A+ lines.
- FreeForm patterns: When recording and in corn rows, the Row Guidance sensors drive the first pass. After that, the guidance system uses the previously recorded pass but augments it with sensor input.
- Curves: When operating on a sharp curve, Row Guidance aggressiveness may need to be increased for performance. See [Row Guidance adjustments \(page 436\)](#).

To open the Row Guidance panel, at the *Run* screen tap .

Use row sensors





To use the sensors:

1. Make sure the Autopilot system is engaged.
2. Activate the sensors by tapping  on the Row Guidance panel.

When active, the row guidance sensors will feel the number of "strikes" against them. After a set number of strikes, the Row Guidance will determine the average peak displacement of the sensors on each side of the row for the strikes and react to this peak displacement on each side to steer the vehicle until the peak displacements on each sensor are equal.

Note – Row sensors override the set Autopilot guidance line. When you turn around in headlands with the sensor turned on, random strikes on stubble cause the system to veer off the set Autopilot guidance line. It is recommended that you travel through the headlands with Autopilot only to guide to the proper row. After you enter the unharvested crop, activate the sensors for row guidance.

On the Row Guidance panel, the sensor button/indicator shows the status of the sensors.

Indicator/Button	Explanation
 (Yellow)	Row sensors are on but not active.
 (Green)	Row sensors are on and active. Tap to turn sensors off.
 (Gray)	Row guidance sensors are off. Tap to turn row guidance sensors on and off while the Autopilot system is engaged. The guidance system will now function as a traditional Autopilot system
	There is an error with the sensors.

Shift or skip guidance line

You may need to skip the guidance line to coordinate with the crop and guidance line if you operate in a crop that was planted:

- Without automatic steering
- Using WAAS corrections and is being harvested using WAAS guidance

In either case, satellite drift and/or operator guidance can lead to misalignment of the guidance line with the crop. Depending on conditions, it may be necessary to shift or skip the guidance line to coordinate with the crop and guidance line. This will be evident when the sensors guide down the proper row with offline distance is shown to be 0, but the selected guidance line is not centered on the current swath on the screen.

In this case it is recommended to skip (temporarily move the guidance line) to align with the drifted crop rows. The Autopilot system must be disengaged to skip.

Row Guidance adjustments

On the Row Guidance panel, you can adjust guidance using the following controls.

Control	Explanation
Nudge	<p>Use to correct satellite drift.</p> <p>Nudge adjustments are available for autonomous, WAAS, Omni, and RTX Rangepoint corrections. This adjustment will move the position of the vehicle in the global (cardinal) direction perpendicular to the path traveled in the user defined increment. When a correction is made heading South on a guidance line to the right, the position of the vehicle will be moved to the West. When heading back North, the correction will still be to the West but left to the direction of travel.</p>
Trim	<p>The vehicle can steer offline as a result of:</p> <ul style="list-style-type: none"> • Uneven drag on a vehicle from an unbalanced implement • Uneven drag on a vehicle from soil conditions <p>Trim adjustment is available for RTK and RTX Centerpoint corrections (FS, SS, SC). Trim moves the vehicle perpendicular to the line with reference to the forward direction (to the right or left of vehicle forward travel) the amount setup by the user. For example, while traveling South down a line and the trim is moved 1 inch right (West), when the vehicle is turned around and driven north the correction will still be right of the line which is East on the Northern heading.</p>
Steering Aggressiveness	<p>Use the - and + buttons to adjust how aggressively to command the steering to the guidance line.</p> <p>Aggressiveness should not be set too high. This can cause the vehicle steering not to react to commands (the steering wheels cannot react fast enough to keep up with the steering commands). Instability in steering will result.</p>
Row Guidance Aggr	<p>Use the - and + buttons to adjust how aggressively the vehicle reacts to the input from the Row Guidance sensors.</p>

TrueGuide operation



WARNING – Many large and sudden changes in satellite geometry caused by blocked satellites can cause significant position shifts. If operating under these conditions, auto-guidance systems can react abruptly. To avoid possible personal injury or damage to property under these conditions, disable the auto-guidance system and take manual control of the vehicle until conditions have cleared.

TrueGuide uses a second GPS receiver on the implement to enable the Autopilot system to pull the implement onto the guidance line.

To open the TrueGuide panel, at the *Run* screen, tap .

Control	Explanation
Trim	
Aggr	<p>Adjust aggressiveness during operation. Use the - and + buttons to adjust how aggressively the implement moves to the guidance line.</p> <ul style="list-style-type: none"> • To increase the response to move the implement back to the line, increase aggressiveness. • To smooth the response to the implement moving offline, decrease aggressiveness <p>The recommended settings for default values are:</p> <ul style="list-style-type: none"> • For steep slopes (10% - 30%): 150% • For slow speed applications: 125% • For normal operation: 100% • For high speed applications (>8 mph): 33%
TrueGuide engagement	<p>On: When the right-hand button displays ON, the Autopilot system is engaged. Auto: When the right-hand button displays AUTO, the TrueGuide system is engaged. Off: Tap to disengage the TrueGuide system.</p>

Using TrueGuide

1. At the *Run* screen on the TrueGuide panel, tap  (yellow). The right-hand button changes to **ON** and the TrueGuide status changes to *Waiting*.

The Autopilot system acquires the line before transitioning to the TrueGuide system.

The TrueGuide system status remains at *Waiting* while the Autopilot system acquires the line.

After the TrueGuide system has taken control, its status changes to **ON** and the right-hand button changes to **AUTO**.

2. To disengage the TrueGuide system at anytime, tap **OFF** (the left-hand button).

Note – *As soon as the TrueGuide system is disengaged, the Autopilot system immediately begins providing all guidance.*

Note – *To turn on the TrueGuide system when the status is *Waiting*, tap **ON** again.*

TrueGuide system status indicators

The system status displays on the TrueGuide tab between the **Off / On (Auto)** buttons.

TrueGuide Status	Explanation
Off	The TrueGuide system is off.
Disengaged	The TrueGuide system is ready, but not engaged.
Waiting	The Autopilot system is engaged, and the TrueGuide system is preparing to engage after a short pause.
On	The TrueGuide system has engaged and is on.

TrueTracker operation



WARNING – Many large and sudden changes in satellite geometry caused by blocked satellites can cause significant position shifts. If operating under these conditions, auto-guidance systems can react abruptly. To avoid possible personal injury or damage to property under these conditions, disable the auto-guidance system and take manual control of the vehicle until conditions have cleared.

When using TrueTracker with the Autopilot system, the implement receives its own separate guidance and steering to increase accuracy.

TrueTracker controls



To open the TrueTracker panel, tap  .

Control	Explanation
Nudge	<p>The guidance line can move off target due to either:</p> <ul style="list-style-type: none"> • GPS position drift after pausing or turning off the system • GPS satellite constellation changes as you drive in the field <p>Use the < and > buttons to move the guidance line in a perpendicular direction (left or right).</p>
Aggr	Use the - and + buttons to adjust how aggressively the implement moves to the guidance line.
Zero Steering	<p>Off: Zero Steering is not used.</p> <p>On: Commands the steering to zero degrees left/right, centering the steering device on the implement. This option can be turned on in the field, keeping the coulters pointed straight, or just at the ends of the field to center the steering.</p> <p>Note – Disengaging the TrueTracker system automatically turns off Zero Steering.</p>
Engage (Green)	<p>For the main button color: Vehicle steering is engaged.</p> <p>For the smaller inner color on the button: Implement steering is engaged.</p> <p>For settings on Engage, see Engage settings for TrueTracker system (page 290).</p>
Engage (Red)	<p>For the main button color: Vehicle steering cannot engage.</p> <p>For the smaller inner color on the button: Implement steering cannot</p>

Control	Explanation
	engage. For settings on Engage, see Engage settings for TrueTracker system (page 290) .
Engage (Yellow)	For the main button color: Vehicle steering is ready to engage. For the smaller inner color on the button: Implement steering is ready to engage. For settings on Engage, see Engage settings for TrueTracker system (page 290) .

Implement status

GPS status

Tap the second  to view status on the implement receiver:

- Implement GPS Status
- Implement Correction Type
- Implement Correction Age
- Latitude
- Longitude
- Altitude
- Satellites
- HDOP
- VDOP
- Network ID

Text

A number of status text items provide information about the implement. You can set these status text items to appear permanently at the top of the screen or on a slide-out tab. To set up status items, see [Status items \(page 79\)](#).

Implement on-screen lightbar

When implement steering is enabled, a second, smaller lightbar displays on the screen below the main lightbar.



The lower lightbar shows the implement guidance relative to the guidance line. Each LED on the second lightbar represents 1 inch.

Vehicle Sync operation

Vehicle Sync replaces the transfer of data using a USB drive. Instead, data is transferred wirelessly between vehicles. Real-time, up-to-date information improves operational efficiency and accuracy. Multiple operators belonging to the same WorkGroup in the same field can transfer location information on other vehicles and:

- Point/line/area features
- Coverage mapping and implement section switching
- Productivity and operational statistics and conditions

Vehicles using Vehicle Sync can also share data on:

- Yield and moisture
- Tank levels
- Location and speed

Common uses

You can use Vehicle Sync for:

- Same operation: Multiple vehicles and implements in a Vehicle Sync WorkGroup performing the same tasks (such as spraying, planting or harvesting)
- Same field, different operation: Multiple vehicles and implements performing different tasks (such as a sprayer working with a planter or a harvester working with a grain buggy)
- Observation: A vehicle can see the location and productivity of the WorkGroup, but does not share coverage, lines or points.

Benefits

Vehicle Sync assists in:

- Planting: Using Field-IQ provides clutch triggering based on coverage sharing, which maximizes input conservation.
- Spraying: Sharing tank level and as-applied information
- Harvesting: Maintaining yield-to-area integrity within the harvest data, and sharing instant yield and moisture information

Using Vehicle Sync

Up to six vehicles can join a Vehicle Sync WorkGroup by joining the same channel.

Join a WorkGroup

To sync with a specific vehicle, make sure:

- Your vehicle has a clear line of sight with that vehicle.
- You are within a distance of 325 yards (300 meters) from that vehicle.
- At least one vehicle is working in an open field.

To link with a vehicle, see .

Guidance lines with Vehicle Sync

You create guidance lines as normal (with the exception of adaptive curves and Free Form lines that are not supported by Vehicle Sync).

Naming guidance lines

To avoid any confusion, it is recommended that you take care in naming guidance lines. All guidance lines are automatically combined together, including lines that vehicles possessed prior to linking. If guidance lines have the same name prior to linking (for example, if both vehicles have a line called *AB line 1*), Vehicle Sync reviews the lines to determine whether they are the same or different:

- If they are exactly the same, they are not duplicated.
- If there is a difference, the lines are pooled and labeled with the tractor from which they have come (for example, for both Tractor A and Tractor B, *AB line 1* will be relabelled in all guidance line pools as *AB Line 1 Tractor A* and *AB Line 1 Tractor B*).

Note – *Vehicle Sync will not shift lines to account for different implement widths. The actual line is transferred.*

If you are performing an operation in which all vehicles have the same swath width and use the same guidance line, the line on which the other vehicle is engaged becomes dotted, as shown for H1:

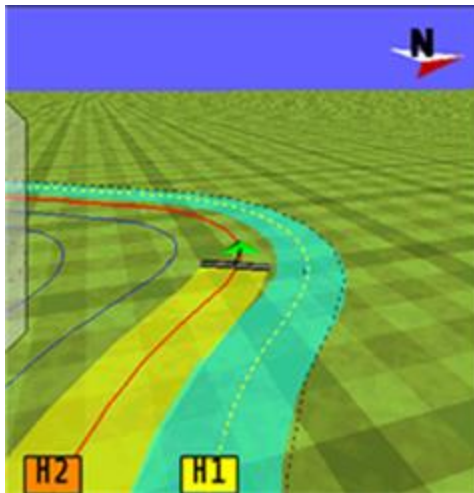

Although you can engage on this line, an alert will display to inform you that you are engaged on the same line as another vehicle.

Coverage

Your vehicle coverage is colored yellow on the screen. When the vehicle sync layer is selected (for events that have the same Client/Farm/Field/Event), the coverage associated with other vehicles will be color coordinated to that vehicle.



View only layer

When vehicles are not in the same event, a *View Only* layer is shown for those vehicles that does not affect section control.

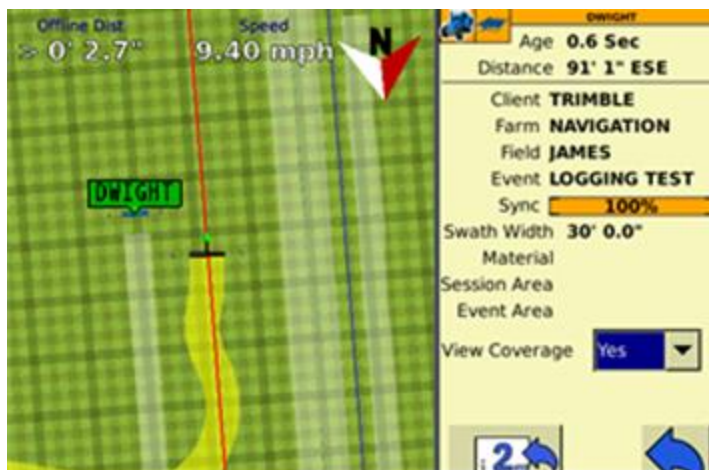

There is also the option to show only the coverage logged by your vehicle.



Coverage controls the following:

- Tru Count clutches
- Liqui-Block clutches
- "Rate as" section
- Header swath width for yield calculation
- Sprayer sections

Note – The warning *EventMemoryLow* displays when the size of the file in the current event exceeds the memory capacity of the display. If this warning displays, exit the current field and begin a new event with a similar name.

Water Management functionality

The functions you can perform with Water Management features include:

- [Create a survey \(page 446\)](#)
- [Create / save a design \(page 449\)](#)
- [Leveling \(page 450\)](#)
 - [Point and Slope mode \(page 455\)](#)
 - [Flat Plane \(Laser\) and Flat Plane \(GPS\) modes \(page 456\)](#)
 - [Contour mode \(page 460\)](#)

For dual or tandem operations, there are:

- [Dual scraper controls \(page 462\)](#)
- [Tandem scraper controls \(page 463\)](#)

Create a survey

The steps to create a survey are:

1. [Create benchmarks \(page 446\)](#).
2. [Survey the field \(page 447\)](#).

Create benchmarks

Before you can create a survey, you must set a point at a known location called a benchmark. When you create a benchmark, the GPS receiver obtains and records location information from the base station for that specific point in your field.

When you are leveling, you use benchmarks to:

- Return to a point in the field with known coordinates to re-calibrate your exact position. This may include setting the bucket on the ground or on a solid surface that will not be disturbed while you perform field leveling.
- Move the design up or down to match the field surface at that point.

The first benchmark you create on a field is the master benchmark and displays as an orange flag labeled **MB** . Field coordinates are calculated from this point.

Subsequent benchmarks display as orange flags labeled with their corresponding number .

Benchmark steps

1. Place the GPS antenna in a known, repeatable location that will not change throughout the leveling of a field.

Tip – Mark this location with flags or some other marker so that you can return to the exact spot.

2. Stop the vehicle.
3. On the WM-Survey tab, tap **Bench**.

Note – If *FieldLevel II* is installed, you can tap **Bench** on that instead. Both **Bench** buttons have the same effect.

A countdown timer runs for 30 seconds and then the system creates the benchmark. To stop the averaging during the countdown, tap **Bench** again.

Note – If you are within the circle around an existing benchmark, a new mark is not created.

Survey the field

After you create the benchmark(s), collect field layout data by conducting a survey.

Define the boundary

Define a boundary to establish the confines of your field. Drive around the boundary while you record the shape.

1. At the *Run* screen, tap  to open the Survey/Design panel.
2. Before driving the boundary, select the reference point you want to use for recording the boundary.
 - Center: Records the boundary based on the location of the antenna.
 - Left: Records the boundary offset half of the implement width to the left of the direction of travel.
 - Right: Records the boundary offset half of the implement width to the right of the direction of travel.
3. Select Boundary from the list.
4. Tap **Record**.
5. Drive the boundary while recording. The boundary records with a line showing it begins and ends at the starting point. (The boundary is a complete loop.)
6. After you have driven to the end of the boundary, tap **Record** again.

Define interior points

To complete a full survey, create guidance lines and then drive over all of the interior of the field boundary, while the system records interior points.

1. At the Survey/Design panel, select *Interior* from the list.
2. Tap **Record** and drive around the interior of the field, gaining enough coverage to produce a height map. You can change the data logging intensity in the FieldLevel II Survey/Design settings (Coarse = 25 ft; Medium = 10 ft; Fine = 5 ft).

Define a section (optional)

After you create a boundary, you have the option to create sections that split the entire area into portions. This enables you to create a design for each section instead of the entire area.

Sections can be useful after you finish working on the area for the day. Define the area that you completed as a section. When you return to the area, you can level the remaining area to a second best-fit plane. See [Design \(page 448\)](#).

There are two methods for defining a section.

- Method 1:
 - Begin recording the section line outside the boundary.
 - Drive through the field to define the section line, then cross outside the boundary again.
 - The section is defined.
- Method 2:
 - Record a section line inside the boundary.
 - The ends of the line will extend to meet the boundary.

Design

After you have completed the survey, the system can create the design based on the information gathered by the survey and the settings you enter as part of the design process. FieldLevel II defines the three-dimensional height for the field and controls how the implement reshapes the ground.

The Autoplane functionality uses the topographic survey of your field to estimate its surface elevations.

You can accept the AutoPlane calculation and have the system create a best-fit design, or manually edit settings, including:

- Cut/Fill ratio: Amount of cut dirt that equals one volume of fill dirt.
- South --> North Slope: Angle of the slope from North to South.
- West --> East Slope: Angle of the slope from West to East.

- **Composite Slope:** The true angle of the fall of the design. In other words, the angle of the slope when the two slope angles are combined.
- **Slope Heading:** The heading direction of the slope when the East/West and North/South slopes are combined.

Create / save a design

After you complete the survey, the **AutoPlane** button displays on the Survey/Design panel.

To create a design for the optimum slope for your field that requires the minimum amount of dirt to be moved:

1. Tap **AutoPlane**. The *AutoPlane* screen displays.

If necessary, you can manually adjust the angle of the slope. However, this may require a greater amount of dirt to be moved because the original design was the optimum.

2. Complete the settings.

If necessary, you can manually adjust the angle of the slope. However, this may require a greater amount of dirt to be moved because the original design was the optimum.

Setting	Explanation
Cut/Fill Ratio	The amount of cut material that equals one volume of fill material.
Section	If you set up sections when you defined the field, you can select a section from the list. <ul style="list-style-type: none"> • None: Levels the entire field. • Left: Levels only the section to the left of the section line. • Right: Levels only the section to the right of the section line.
Composite Slope	The true angle of the fall of the design when the East/West and North/South slopes are combined.
Slope Heading	The heading direction of the slope when the East/West and North/South slopes are combined.
North -> South Slope	The angle of the design slope from North to South.
East -> West Slope	The angle of the design slope from East to West.
Height or Cut/Fill	Height: Gives the design the theme of a topographic height map. Cut/Fill: Gives the design the theme of a cut/fill map. Red indicates the cut areas. Blue indicates the fill areas. Green indicates areas that do not need cut or fill.

3. Tap **Best Fit**.

The system uses the interior points that you collected to calculate the optimum slope of the field. An arrow displays on the image of the field to show the direction of fall. The **Stats** table lists the statistics of the design computation:

- **Cut:** The volume of material that must be removed for the current design.
 - **Fill:** The volume of material that must be added for the current design.
 - **Area:** The area of the field inside the boundary.
4. Tap **OK** to close the AutoPlane screen and save the design. The the system saves the design as the default plane for this field.

Leveling

Before you begin your leveling operation using Field LevelII, you may need to:



- [Import designs \(page 451\)](#)
- [Reload a field \(page 451\)](#)
- [Re-bench \(page 451\)](#)

Getting started with leveling

The FieldLevel II system automatically raises and lowers the blade on the implement to match the design height anywhere in the field. You will use the color cut/fill map, simple on-screen adjustments, and automatic blade control to perform leveling.

In addition to the following instructions, depending on where you are in your operation, you may need to:

- [Reload a field \(page 451\)](#)
- [Re-bench \(page 451\)](#)

1. Open a field as normal.
2. When your leveling model is set to Multiplane design and the FM-1000 Plus application opens the field, the system:
 - Scans the \AgGPS\Designs\.
 - Opens any Multiplane .gps control files that are close to your current position and displays a list of these files in the *Select Design* screen.
3. Select the design you want to use and tap **OK**.
4. To enter the leveling panel, tap either  or , depending on whether you are using a tandem scraper or dual scraper. See [Dual scraper controls \(page 462\)](#) or [Tandem scraper controls \(page 463\)](#).
5. Determine which leveling model you want to use:

- [Point and Slope mode \(page 455\)](#)
- [Flat Plane \(Laser\) and Flat Plane \(GPS\) modes \(page 456\)](#)
- [Define a plane \(page 457\)](#)
- [Contour mode \(page 460\)](#)

Import designs

After you finish with your design, you can export a control file (.GPS) for use with the FieldLevel II system. Copy the design control file into the \AgGPS\Designs\ folder on a USB drive.

Reload a field

When you create a design for a field (for example, a target leveling plane), the design is saved in the */field/* directory.

The design files are associated with the field. If you close the field and then open it again, the design reloads with the field.

With RTK GPS, the position of the RTK base station is important to the heights used when the field was previously open. If the base station is not accurately positioned in the same physical location, you must reestablish the design over an existing benchmark to re-establish the height.

Re-bench

When you are leveling, you use benchmarks to:

- Return to a point in the field with known coordinates to re-calibrate your exact position. This may include setting the bucket on the ground or on a solid surface that will not be disturbed while you perform field leveling.
- Move the design up or down to match the field surface at that point.

Re-benching is designed to accommodate differences with RTK base station setup from the last time the field was opened.

Manual re-bench

On the Field LevelII panel, if you tap either of the **Re-bench** buttons when the receiver is within the circular radius of a benchmark, the receiver is calibrated over the existing benchmark. Re-benching enables you to synchronize your position with the design you created.

1. Tap **Re-Bench**. A message displays showing a list of the saved benchmarks within the open field. The system automatically selects the benchmark closest to you (if multiple benchmarks exist), but allows you to select the benchmark you want to use.

Note – To ensure the design is properly aligned to the field, return to the exact location of the master benchmark that you marked on the ground (for example, with flags, see [Create benchmarks \(page 446\)](#)), and re-bench on the master benchmark.

2. Select the benchmark to re-bench on.
3. Tap **OK**. A confirmation message displays showing the calculated distance to the selected benchmark.

Note – This calculation may be quite exaggerated if the base was moved a considerable distance away from its previous position.

4. Verify this is the benchmark you want (if multiple benchmarks exist).
5. Tap **OK** to accept the message. The system begins the standard 30-second averaging process to re-establish the field relevance to the benchmark you just re-benched on.

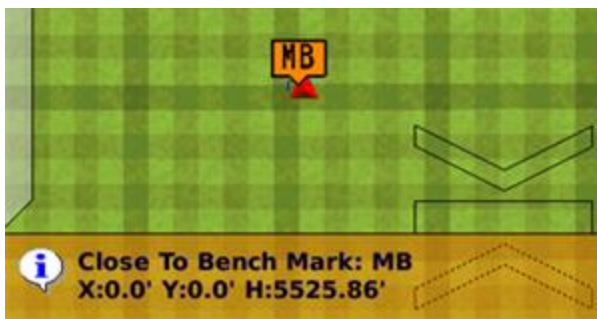





Force re-bench

If you open a field that has an existing master benchmark and have chosen to require Force Rebench (see [Relative Heights tab \(page 314\)](#)), the **Create Benchmark** button label changes to **Re-Bench**. The system will not allow you to engage automatic control until the system has been re-benched.

Note – You must locate the machine exactly over the actual mark on the ground. **Do not** rely on your relative position to the master benchmark if the base station was moved.

Blade level indicators

In the operational view of the *Run* screen, a blade indicator shows the status of the blade related to the On-Grade Limit.

Indicator	Explanation
	The blade is above the target height beyond the On-Grade Limit.
	The blade is below the target height beyond the On-Grade Limit.
	The blade is considerably above the target height, more than double the On-Grade Limit.
	The blade is considerably below the target height, more than double the On-Grade Limit.
	The blade is at the correct target height, within the On-Grade Limit.

When you are using dual or tandem scrapers, you will see two blade indicators on the *Run* screen.

Additionally, you can tap  to open the legend for the operational view of the *Run* screen and select either Height or Cut/Fill.

FieldLevel II status items

Status items are text information that:

- Describe factors in leveling models
- Beginning with P are for the primary GPS receiver (for example, P Blade Height)
- Beginning with S for the secondary if you are using dual or tandem scrapers (for example, S Blade Height)

Status items can be set to always display at the top of the screen or on a slide-out tab. See [Status items \(page 79\)](#).

Status Item	Explanation
Altitude	Current GPS altitude of the blade.
Blade Height	Current height of the blade shown as a relative height or a GPS height depending on settings selected.
Boot Depth	Depth of the boot when installing tiles or the depth of the blade when cleaning surface ditches (used with the Autoslope leveling model).
CMR Percent	Percentage of data being successfully received from the base GPS receiver.
Correction Age	Time since the last GPS correction was received from the GPS base station. Note – Can also be viewed from the Run screen.
Correction Type	Solution type (for example: RTK Fixed, or RTK Float, etc.) Note – Can also be viewed from the Run screen.
Cut/fill	Difference between the blade height and the target height. When Cut is displayed, the current ground height is above the target height, and the height adjustment indicator shows a red down arrow, which means that the blade needs to be moved down to reach the target height. When Fill is displayed, the current ground height is below the target height.
Design Height	Originally planned or designed height at the current location.
Design Slope	Design slope with respect to the current location along the section line. Used with Autoslope leveling model.
Distance Traveled	Distance traveled since Auto mode was enabled. Used with Point to Slope leveling model.
East	Difference in the East component from the Local Tangent Plane (LTP).
GPS Status	Solution type (for example: RTK Fixed, or RTK Float, and so on). Note – Can also be viewed from the Run screen.
H Error	Current estimate of the error in the horizontal component.
HDOP	Horizontal dilution of position. Horizontal component of PDOP.
Heading	Current direction the vehicle is heading in
Latitude	Latitude as recorded by the GPS receiver

Status Item	Explanation
Longitude	Longitude as recorded by the GPS receiver.
Network ID	Network ID of the GPS receiver, which must be the same as the base receiver network ID.
North	Difference in the North component from the Local Tangent Plane (LTP).
Offset	Relative offset in the vertical component.
Offset X	Relative offset in the X axis.
Offset Y	Relative offset in the Y axis.
Satellites	Amount of satellites in the GPS/GLONASS solution.
Section Line Number	Line number selected for design in AutoSlope. This is the current section line being recorded in the field.
Speed	Current speed of the vehicle.
Survey Cut / Fill	Cut/fill for the location of the vehicle within a field that has been processed in AutoPlane.
Target Height	Height the blade will attempt to reach. This is the design height \pm the offset. When the blade reaches the target height, the arrows turn green.
Up	Difference in the up component from the Local Tangent Plane (LTP).
VDOP	Vertical dilution of precision. Vertical component of PDOP .
Vertical Error Estimate	Current estimate of error in the height calculated by the FieldLevel GPS receiver.

Leveling models



You have different leveling options, depending on the leveling mode that you selected:

- Point and Slope mode
- Flat Plane (Laser) and Flat Plane (GPS) mode
- Contour mode

Point and Slope mode

Slope is the percentage of vertical drop compared to horizontal travel. A positive slope goes upward, and a negative slope goes downward. For example, if the slope is set to -1%, the slope will drop 1 ft for every 100 ft horizontally traveled.

When you drive in Point and Slope mode, the Leveling panel displays the following controls.

Button	Explanation
Coarse / Fine	Coarse: The blade will move by large increments. Fine: The blade will move by small increments.
Edit	Tap to view or change the Slope Adjust increment. This setting controls the amount the gradient changes each time you increase or decrease the design slope. For example, if the leveling gradient is set to -3%, and the slope adjust is set to 2%, when you decrease the design slope amount, the leveling gradient decreases to -5%.
	Tap to increase the design slope by the Slope Adjust increment.
	Tap to decrease the design slope by the Slope Adjust increment.
Bench OR Re-Bench	Tap to create a benchmark or re-bench. Set the Design Height equal to the Blade Height.
Delete Benchmark	Tap to remove any benchmark on the field that you have selected. You do not need to drive over a benchmark to delete it.
Logging	Tap to log coverage. This shows on the map where you have been, dependent on your implement width. A shape file is created with cut/fill and height information.
Auto	Engages automatic blade height control: <ul style="list-style-type: none"> • Starts the slope calculation • Resets the height • Resets the cut/fill



Flat Plane (Laser) and Flat Plane (GPS) modes

When driving in Flat Plane mode, these options operate the same:

- Flat Plane (Laser): Use this model when the land has previously been leveled with a laser system and you want to touch up the field. This model results in a mathematically flat surface (which means the plane does not follow the curvature of the Earth, but completely flat).
- Flat Plane (GPS): Results in a design with a surface that is curved the same as the surface of the Earth (an equipotential surface).

Note – Neither of these models can be used with a laser system. The entire FieldLevel II system only works with GPS.

The controls on the Leveling panel for these modes are:

Button	Explanation
Coarse / Fine	Coarse: The blade will move by large increments. Fine: The blade will move by small increments.
	Raises the blade by the fine or coarse increment.
	Lowers the blade by the fine or coarse increment.
Design	Tap to open the Plane Editor. Here you can edit the design plane.
Bench Or Re-Bench	Tap to create a benchmark or re-bench. Set the Design Height equal to the Blade Height.
Delete Benchmark	Removes any benchmark on the field. You do not need to drive over a benchmark to delete it.
Logging	Tap to log coverage. This shows on the map where you have been, dependent on your implement width. A shape file is created with cut/fill and height information.
Auto	Engages automatic blade height control: <ul style="list-style-type: none"> • Starts the slope calculation • Resets the height • Resets the cut/fill

Define a plane

You can define a plane in the *Plane Editor* screen. The controls on the Plane Editor screen enable you to either:

- Design a field slope and orientation
- Set the design parameters for the tile or surface ditch profile

To define a plane, you can use:

- [A single point](#)
- [Multiple benchmarks](#)

Use at least one point as a pivot point and extra information based on direction and slope requirements.

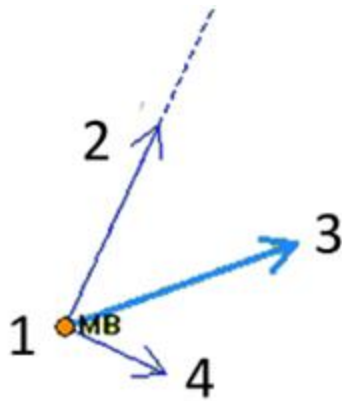

Item	Name	Explanation
1	Pivot Benchmark	The single benchmark where the plane is defined. All slopes will pivot around this point.
2	Primary	The first axis upon which the slope is defined. It has a Primary Slope and Primary Heading component. The Primary Slope is defined as a negative number, where water will fall along the primary axis.
3	Cross	The second axis upon which the slope is defined. The Cross Heading will always be 90° or 270° from the Primary Heading. The Cross Slope is defined as a negative number, where water will fall along the cross axis. To define the plane by a single heading and slope, then you should set the Cross Slope value to 0.000%
4	Composite	When both Primary and Cross slopes are defined, the Composite Slope direction shows the actual heading where water will fall. If you have 0.000% slope on the Cross axis, the Composite Heading will be the same as the Primary Heading.

Use a single point

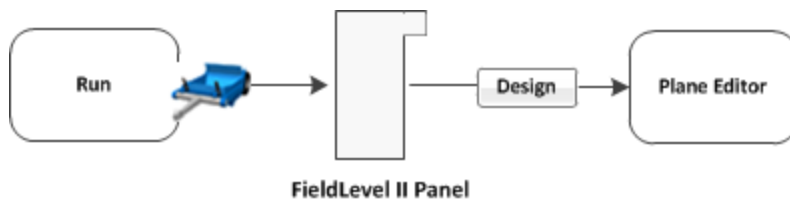

To define a plane using a single point:

1. At the FieldLevel II panel, create a benchmark to define the direction of the slope and its heading.

It can be useful to create the benchmark at the critical point. For example, where the water will enter or exit the field. This ensures that where the benchmark is, the plane is on grade.

2. Tap **Design**. The *Plane Editor* screen displays. Complete the settings and tap **OK**.

Item	Explanation
New Plan	
Choose Pivot	Tap and select the benchmark you want to be on grade.
Primary Slope	If you want to define the primary heading by measuring a second point, see Define a plane (page 457) .
Cross Slope	
Height Above Pivot	Enter the known offset if you are using one.
Primary Heading	
Flip	Tap to change the direction of the Cross Slope. This changes the Cross Heading between 90° and 270° from the Primary Heading.

For water to run along the Primary and Cross axis, the slope values must be keyed in as negative values.

Note – *FieldLevel II* searches for a survey on the field. If there is a survey, a *Cut/Fill* map displays on the new design plane.

Use multiple benchmarks

You can use multiple benchmarks to define a plane based on your specific requirements. If multiple benchmarks are created, you can design a plane of best-fit through them.

If you use three benchmarks to design the plane, the cut and fill values will be "0.0" through those points so the system can create a perfect plane. If you use more than three benchmarks to design the plane, the cut/fill values will be the residual difference between the plane of best-fit and the benchmark elevations.

To define a plane using multiple points:

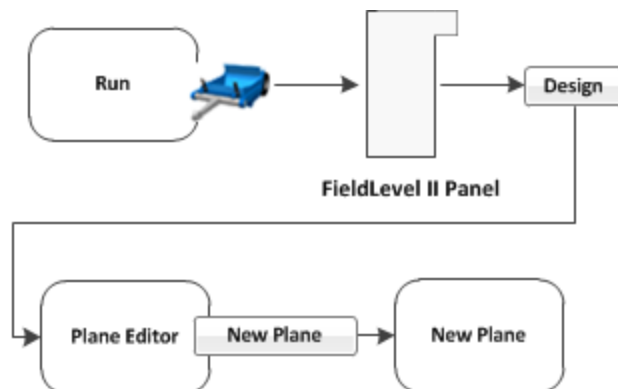



1. At the FieldLevel II panel, create two or more benchmarks to help define the plane. If a primary heading definition is required you only need two benchmarks. If all the slopes of a field are to be defined, then you need at least three benchmarks. Select the FieldLevel II plugin and tap **Design**. The *Plane Editor* screen displays.
2. Tap **New Plane**. The *New Plane* screen displays.
3. From the Benchmarks list, select the benchmark you want to use for the primary pivot, then tap **Add**. The benchmark is copied to the Design Benchmarks list.
4. Repeat the previous step until all the required benchmarks are copied to the Design Benchmarks list. The Design Benchmarks list contains the benchmarks for the multi-point plane.
5. Set the Primary Slope Heading:
 - a. Choose the first benchmark to define the heading and then tap the **Set> From:** button.
Note – It is recommended that this point is the uphill point of the two points that will be used to define the primary slope.
 - b. Select the second point of the primary slope and then tap the **Set> To:** button.
 - c. Tap **OK**. The *Plane Editor* screen displays.
The selected benchmarks appear in the Benchmarks table on the upper left along with their associated cut/fill values. The Primary Slope and Cross Slope values reflect the calculated slopes based on the benchmarks entered in the *New Plane* screen.
6. To update the slope values:
 - a. Identify the benchmark to be used as the new pivot.
 - b. Tap **Choose Pivot**. The *Choose Pivot* screen displays.
 - c. Select the benchmark to be used as a the pivot for the new slope from the screen.
 - d. Tap **OK**. The *Plane Editor* screen displays.
7. Select the Primary Slope, Cross Slope, or Height Above Pivot areas to edit the slope values as required.
Note – The cut/fill values in the Benchmarks table will update automatically.
8. The plane is now defined. Tap **OK**. The *Run* screen displays.
Note – The FieldLevel II system will search for a survey on the field. If there is a survey, a cut/fill map displays as the new design plane.

Contour mode

1. At the *Run* screen, drive the vehicle to the location where you want to start the first levee.
2. Set the master benchmark at this point.
3. Set which side of the vehicle is uphill.
4. Tap **Guide** and drive the vehicle forward, following the lightbar to keep the vehicle on the same contour.

- a. To move to the next levee, turn the vehicle around and change the UpHill direction.
- b. To step the blade up or down, use the and plus and minus buttons to achieve the required offset and then follow the lightbar to keep the correct grade.

When you drive in Point and Slope mode, the FieldLevel II panel displays these controls.

Button	Explanation
Coarse / Fine	Coarse: The blade will move by large increments. Fine: The blade will move by small increments.
	Raises the blade by the fine or coarse increment.
	Lowers the blade by the fine or coarse increment.
Up Hill Left	Select if you are driving around the contour with the uphill slope on your left and the downhill slope on your right.
Up Hill Right	Select if you are driving around the contour with the uphill slope on your right and the downhill slope on your left.
Bench Or Re-Bench	Tap to create a benchmark or re-bench. Set the Design Height equal to the Blade Height.
Delete Benchmark	Removes any benchmark on the field. You do not need to drive over a benchmark to delete it.
Logging	Tap to log coverage. This shows on the map where you have been, dependent on your implement width. A shape file is created with cut/fill and height information.
Guide	Tap to get lightbar guidance at the current level.

Dual scraper controls

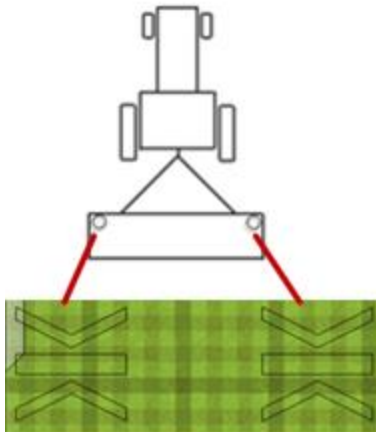

Blade height indicators:

- The left height indicator shows the height of the left/primary blade.
- The right height indicator shows the height of the right/secondary blade.

Left plus and minus: Controls the blade height for the left/primary blade.

Right plus and minus: Controls the blade height for the right/secondary blade.



P: AUTO : Controls the left/primary automatics

S: AUTO : Controls the right/secondary automatics

Tandem scraper controls

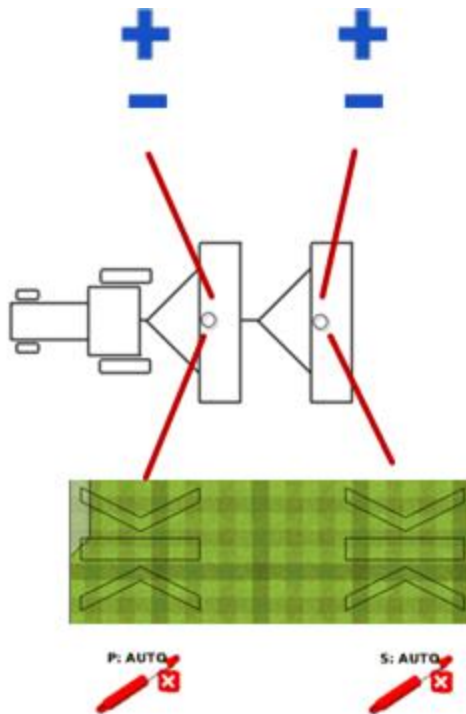

Left plus and minus: Controls the blade height for the front/primary blade.

Right plus and minus: Controls the blade height for the rear/secondary blade.

Blade height indicators:

- The left height indicator shows the height of the front/primary blade.
- The right height indicator shows the height of the rear/secondary blade.



: Controls the front/primary automatics



: Controls the rear/secondary automatics

WM-Drain operation



To use WM-Drain, you use the following to edit the survey and design, and to install tile or perform ditch cleaning:

- [Survey tab \(page 465\)](#): [Set survey height offset \(page 473\)](#) and [Create a tile / ditch survey line \(page 474\)](#)
- [Design tab \(page 467\)](#) and [Design screen \(page 468\)](#): [Design a section line \(page 474\)](#), [Clip a portion of a section line \(page 477\)](#) and [Add a fixed point \(page 477\)](#)
- [Install tab \(page 466\)](#): [Installation/ditch cleaning \(page 478\)](#)

Survey tab

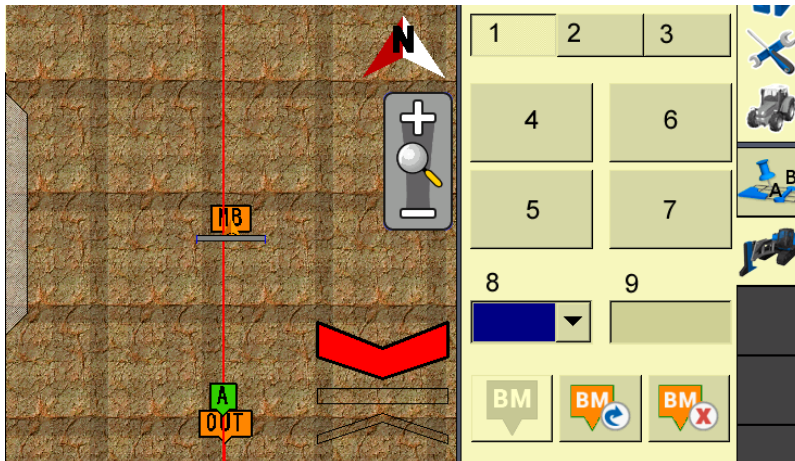
The Survey tab is used to create a survey by creating a master benchmark and logging survey points while driving the area you want to survey.





Item	Explanation
1	Survey tab
2	Design tab (page 467)
3	Install tab (page 466)
4	Record Section button
5	Pause Section button
6	Delete Section button
7	Manual Data Point button
8	Type of design: Main
9	Size of design
	Create Benchmark: Tap to create a benchmark
	Rebench: Tap to rebench
	Delete Benchmark: Delete a benchmark

Install tab

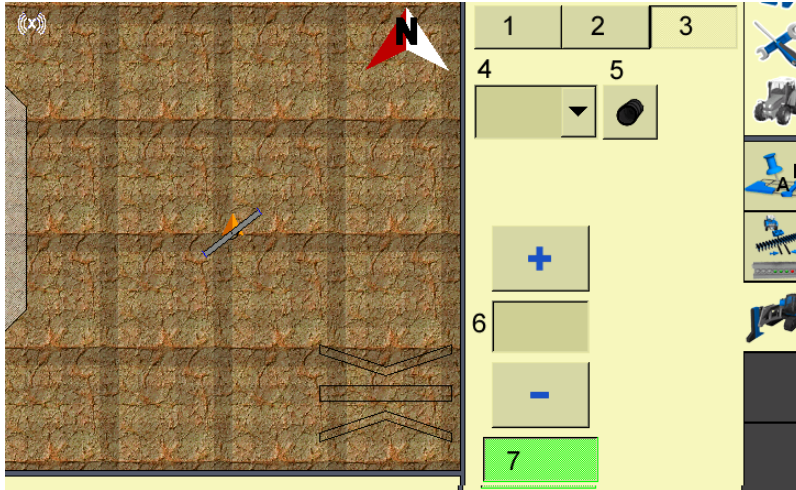
On the Install tab, you perform installation.



Item	Explanation
1	Survey tab (page 465)
2	Design tab (page 467)
3	Install tab
4	Mode:
5	Type of pipe: The type of pipe to install. Options are: Main, Sub-Main, Lateral
6	Height Offset controls  - Decrease height offset  - Increase height offset
7	Choice of Coarse or Fine increments for changing height offset

Design tab

On the Design tab, you choose a section to design and tap **Design**. The [Design screen \(page 468\)](#) opens.

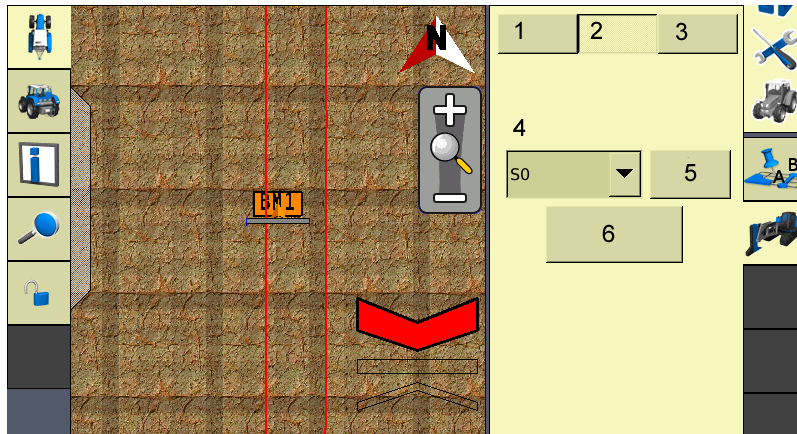

Item	Explanation
1	Survey tab (page 465)
2	Design tab
3	Install tab (page 466)
4	Section; Section chosen to design
5	Select Closest button: Tap to choose the closest section
6	Design button: Tap to open the Design screen (page 468)

Design screen

At the Design screen, you determine the design of the section line you have chosen.

Settings Tab

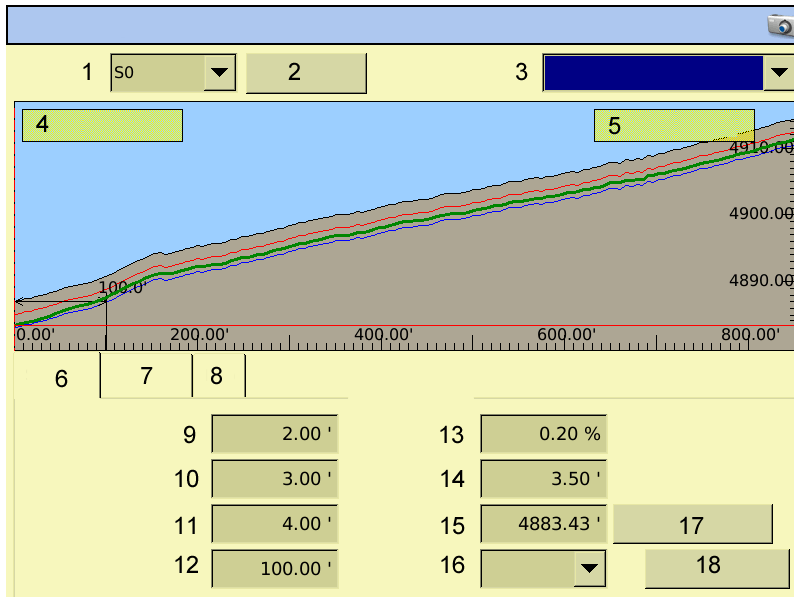

Item	Explanation
1	Section: The section you are currently designing.
2	Rename button: Tap to rename the section.
3	Direction list: The design screen shows the outlet at the left side of the screen and runs the design uphill to the right side of the screen. The direction of the profile is defined by the direction that it was surveyed. If your survey profile is displayed the other way, switch the option shown in the Direction list to the other option in the list. Options are: <ul style="list-style-type: none"> • Outlet at Survey Start • Outlet at Survey End
4	Outlet information: Elevation of outlet depth.
5	Boot Slope information: The current reading for the boot slope from the IMD-600.
6	Settings tab

Item	Explanation
7	Edit Line tab
8	Info tab
9	<p>Minimum Depth: The minimum depth for the tile or ditch installation. The system will not allow the design profile to be any shallower than the minimum depth, which is shown on the profile as a red line.</p> <p>Note – For ditching applications, this depth is set close to the surface</p>
10	<p>Optimal Depth: The depth to install the tile or ditch. The design will keep this to the depth when it can. It will move off the optimal depth to be within the other constraints where it is needed.</p> <p>Note – For ditching applications, this depth is set close to the surface.</p>
11	<p>Maximum Depth: The maximum depth for the tile or ditch installation. The system will not allow the design profile to be any deeper than the maximum depth, which is shown on the profile as a blue line.</p>
12	<p>Outlet to Optimal: The distance it takes to change the depth of the design from the Outlet Depth to the Optimal Depth. The tile plow will level out over a long distance rather than trying to achieve the depth too quickly at the start of a run.</p>
13	<p>Minimum Slope: The minimum slope for the tile or ditch installation. The system will not allow the design to slope to be any less than the minimum slope.</p>
14	<p>Outlet Depth: The depth at which the design profile will be at the outlet. This depth can either be entered or measured. To measure the depth:</p> <ol style="list-style-type: none"> 1. Drop the tile plow into the ground so the boot is at the same height as the main or outlet. 2. Tap Measure. The outlet depth is entered by the system. Also, another point is added to the section line if you are within 20 m (65 ft) of the end of the surveyed section line. <p>The height of the outlet is shown by a yellow tag.</p>
15	<p>Outlet Elevation: The real or relative elevation of the outlet.</p>
16	<p>Smoothing list: The required smoothing level (None, Low, Medium, High) to work out any humping sections in the design. It is recommended you use either Low or Medium smoothing.</p>
17	<p>Measure Outlet button: Tap to show the outlet depth and outlet elevation layers with the current boot depth in relation to the surveyed surface.</p>
18	<p>OK button: Tap to save any changes to the design.</p>

Edit Line tab

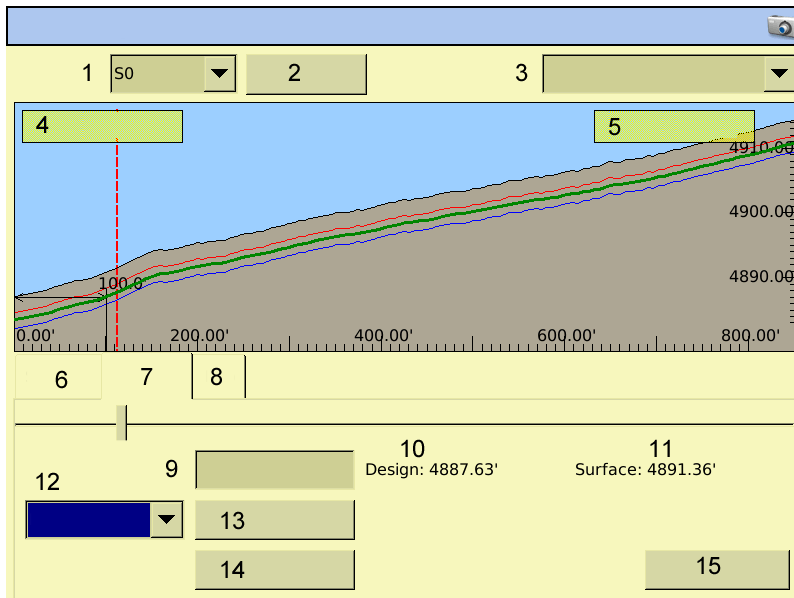

Item	Explanation
1	Section: The section you are currently designing.
2	Rename button: Tap to rename the section.
3	<p>Direction list:</p> <p>The design screen shows the outlet at the left side of the screen and runs the design uphill to the right side of the screen. The direction of the profile is defined by the direction that it was surveyed. If your survey profile is displayed the other way, switch the option shown in the <i>Direction</i> list to the other option in the list.</p> <p>Options are:</p> <ul style="list-style-type: none"> • Outlet at Survey Start • Outlet at Survey End
4	Outlet information: Elevation of outlet depth.
5	Boot Slope information: The current reading for the boot slope from the IMD-600.
6	Settings tab
7	Edit Line tab
8	Info tab
9	Distance: The distance of the fixed point from the beginning of the line.

Item	Explanation
	Clipping Distance: The distance from the beginning of the line.
10	Design information: Elevation of the designed section at that location.
11	Surface information: Elevation of the surface at that location.
12	Design Tool list: Options: Clip Start, Clip End, Fix Point.
13	Add button: Tap to add a fixed point to the design. Clip button: Tap to clip the designated portion of the section line.
14	Delete All button: Tap to delete all of the fixed points created.
15	OK button: Tap to save any changes to the design.

Info tab

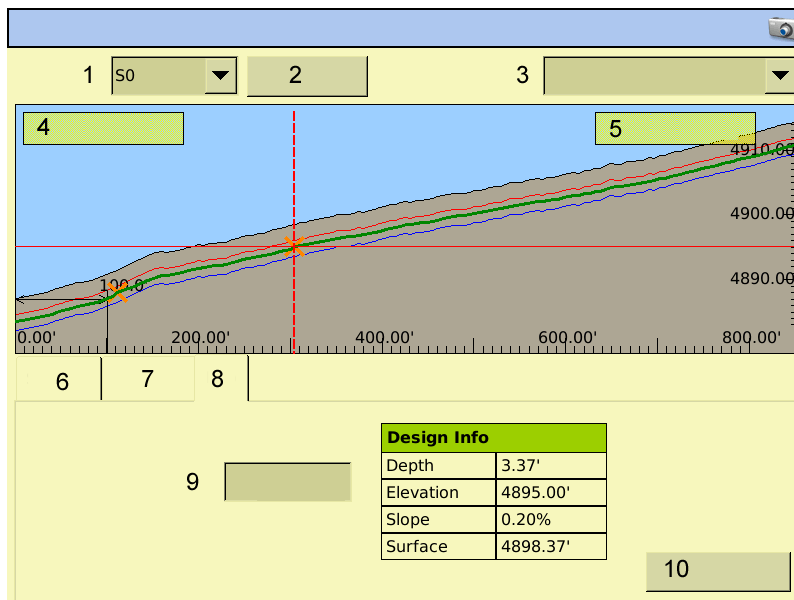

Item	Explanation
1	Section: The section you are currently designing.
2	Rename button: Tap to rename the section.
3	Direction list: The design screen shows the outlet at the left side of the screen and runs the design uphill to the right side of the screen. The direction of the profile is defined by the direction that it was surveyed. If your survey profile is displayed the other way, switch the option shown in the Direction list to the other option in the list.

Item	Explanation
	Options are: <ul style="list-style-type: none"><li data-bbox="363 394 660 427">• Outlet at Survey Start<li data-bbox="363 443 647 477">• Outlet at Survey End
4	Outlet information: Elevation of outlet depth.
5	Boot Slope information: The current reading for the boot slope from the IMD-600.
6	Settings tab
7	Edit Line tab
8	Info tab
9	Distance: The selected location's distance from the start of the section line.
10	OK button: Tap to save any changes to the design.

Set survey height offset

To set the Survey Height Offset:



1. At the *Home* screen, tap . The *Configuration* screen displays.
2. Select  WM-Drain and tap **Setup**.
3. On the tile plow, raise the boot as high as it will raise.
4. Measure the distance from the bottom of the tile boot to the ground.
5. Enter this value into the Survey Height Offset entry box.

Note – *It is recommended that you change the survey point spacing to 1.5m (5 feet). This will then record the survey points every 1.5M (5 feet) and provide a more accurate profile of the ground surface.*

6. Tap **OK**.

Create a tile / ditch survey line

Before creating the survey line, [Set survey height offset \(page 473\)](#). This offset will be applied to the heights of your surveyed alignment so that you do not need to rebench before installing tile.

1. At the *Run* screen, tap  to open the WM-Drain panel.
2. Go to the Survey tab of the panel.
3. Drive to a point that will be untouched to use as a reference point.
4. Tap  to create a master benchmark and flag this point so you can find it again easily.
5. Drive the vehicle to the start of the line where you want to install tile or clean a ditch.

Note – For the most efficient method, it is recommended that you drive to the high end of the line.
6. From the Type list, select the type of design. The options are Main, Sub main and Lateral.
7. In the Size entry box, enter the size of the design.
8. Tap **Record Section** to begin recording a section and then drive. To pause recording, tap **Pause Section**. (The **Record** button changes to white when activated.)

If you have created a section you want to remove, tap **Delete Section** and choose the section from the list that displays.

Note – For the most efficient method, it is recommended that the end point is where the tile line is to be connected to a main or outlet.
9. To add a manual survey point at a distance different from the normal survey distance, tap **Manual Data Point**.
10. Tap **Record** again to stop the recording.
11. If you create a benchmark you want to remove, tap  and choose the benchmark from the list that displays.

Design a section line

After you create survey lines, use design screen to create designs for installing tile or cleaning ditches along those lines.

1. At the *Run* screen, tap  to open the WM-Drain panel.
2. Go to the Design tab of the panel.
3. From the Section list, select the section line that you want to design and tap **Edit Design**.
4. If required, tap **Select Closest**. This enables you to select the line that is closest to you. If there is more than one line within 10 m of your current position, the *Select Closest Section Line* screen

displays. The line that is calculated as being closest to you is highlighted. The section line number and pipe type are shown. Choose the line you want and tap **OK**. The system displays the *Design* screen.

- At the *Design* screen, from the Section list choose the section line you want to design.

Setting at Top of Screen	Explanation
Section Selection	Auto: The nearest section line is automatically selected. Manual: Manually select a section from the list.
Rename button	Tap to rename the section name.
Direction	The design screen shows the outlet at the left side of the screen and runs the design uphill to the right side of the screen. The direction of the profile is defined by the direction that it was surveyed. If your survey profile is displayed the other way, switch the option shown in the Direction list to the other option in the list. Options are: <ul style="list-style-type: none"> • Outlet at Survey Start • Outlet at Survey End

Note – The section lines are labeled automatically by the system (beginning at S1) in the sequence they were surveyed.

- Edit the design to your requirements.

On the Settings tab, set:

Settings Tab	Explanation
Min Depth	The minimum depth for the tile or ditch installation. The system will not allow the design profile to be any shallower than the minimum depth, which is shown on the profile as a red line. Note – For ditching applications, this depth is set close to the surface.
Optimal Depth	The depth to install the tile or ditch. The design will keep this to the depth where it can. It will move off the optimal depth to be within the other constraints where it is needed. Note – For ditching applications, this depth is set close to the surface.
Max Depth	The maximum depth for the tile or ditch installation. The system will not allow the design profile to be any deeper than the maximum depth (shown as a blue line).
Outlet to Optimal	The distance it takes to change the depth of the design from the Outlet Depth to the Optimal Depth . The tile plow will level out over a

Settings Tab	Explanation
	long distance rather than trying to achieve the depth too quickly at the start of a run.
Min Slope	The minimum slope for the tile or ditch installation. The system will not allow the design to slope to be any less than the minimum slope.
Outlet Depth	The depth at which the design profile will be at the outlet. This depth can either be entered or measured. To measure the depth: <ol style="list-style-type: none"> Drop the tile plow into the ground so the boot is at the same height as the main or outlet. Tap Measure. The outlet depth is entered by the system. Also, another point is added to the section line if you are within 20 m (65 ft) of the end of the surveyed section line. The height of the outlet is shown by a yellow tag.
Outlet Elevation	Elevation of outlet depth.
Smoothing	The required smoothing level (None, Low, Medium, High) to work out any humping sections in the design. It is recommended you use either Low or Medium smoothing.
Measure Output button	Tap to show the outlet depth and outlet elevation layers with the current boot depth in relation to the surveyed surface.
Distance	Tap the design graph or enter a distance to display the Design Info (depth, elevation, slope, surface) for that location.

7. On the **Edit Line** tab, you have the options to:
 - a. Indicate fixed points on the line. See [Add a fixed point \(page 477\)](#).
 - b. Clip and remove sections of the line. See [Clip a portion of a section line \(page 477\)](#).
8. Tap **OK**.

At the **Run** screen, you can install the tile or clean the ditch from either the outlet or the top end of the profile. The section line that you use for installation or cleaning will display as red on the screen (other section lines are white).

Add a fixed point

You can add a fixed point to your design. This enables you to avoid:

- An underground structure
 - Intersecting a specific depth or existing tile line
1. At the *Design* tab, tap **Design** to open the *Design* screen.
 2. Go to the *Edit Line* tab.
 3. From the far left-hand list at the bottom of the screen, choose *Fix Point*.
 4. Indicate where you want the fixed point by:
 - a. Touching on the screen
 - b. Moving the slider
 - c. Entering a specific distance in the *Distance* entry box
 5. Tap **Add**. The screen will show the design elevation for the fixed point.
 6. Enter the elevation that represents the target or obstacle. The system redesigns the section line to account for the new fixed point. If the slope approaching the point is now too steep, you have the option to enter more fixed points ahead of the original fixed point to make the transition better from one slope to the next.

Clip a portion of a section line

You can remove a portion of the section line from either the beginning or end of the line (or both).

1. At the *Design* tab, tap **Design** to open the *Design* screen.
2. Go to the *Edit Line* tab.
3. From the far left-hand list at the bottom of the screen, choose either *Clip Start* Or *Clip End* (depending on which end of the line you want to remove).
4. Indicate where you want to clip to by:
 - a. Touching on the screen
 - b. Moving the slider
 - c. Entering a specific distance in the *Distance* entry box
5. When you have finished indicating the areas to clip, tap **Delete All**.
6. To save the changes, tap **OK**.

Installation/ditch cleaning

Autoslope mode



You can use the Autoslope mode for:

- For tile applications: The system runs on both self-propelled tile machines and pull-type plows towed behind a tractor.
- For ditching applications: You can use any type of scraper or ditching machine supported by the WM-Drain system.

Note – When the system is not running in Autoslope mode, the on-screen or LB25 lightbar will guide to any existing A-B line. This means you can use manual guidance for surveying in section lines to be tiled at a consistent spacing.

1. At the *Run* screen, tap  to open the WM-Drain panel.
2. Go to the *Install* tab of the panel. Use the controls for installation or ditch cleaning.

Control	Explanation
Survey	Tap to open the <i>Survey</i> screen where you can survey the section line you will design.
Design	Tap to open the <i>Design</i> screen where you can select a section line and then edit the design. Note – A white cross displays on the <i>Run</i> screen to show both the horizontal and vertical location.
Mode	<ul style="list-style-type: none"> • Autoslope: Creates sloped tile or surface drainage targeting the optimal depth defined on the <i>Design</i> tab. • Slope: Creates consistently sloped tile or surface drainage. From the starting point, the vehicle levels at a constant slope, regardless of direction. • Constant Depth: Use to collect a live, rolling survey of the ground surface. This survey is passed in real time to the control system, which enables it to run at the specified depth above or below the ground surface. The constant depth mode can only be accessed when you have properly configured manual guidance, Autopilot or EZ-Pilot. This mode requires two RTK-enabled receivers are available and assigned on the system. One of the RTK-enabled receivers: <ul style="list-style-type: none"> • Is not required to be an internal receiver

Control	Explanation
	<ul style="list-style-type: none"> • Must be assigned to the appropriate guidance plugin/feature • Must be mounted in front of the antenna used for WM-Drain
Pipe	Pipe Type: Select the type of pipe to be installed. Pipe Size: The size of the pipe to be installed.
Recalc	When the tile plow encounters a rock, pull the boot up over the rock and tap Recalc . This modifies the design to ensure the remaining tile run stays within the minimum slope requirement and prevents the pipe from diving down to the original design grade. Note – This works only when installing tile in the direction away from the outlet point.
Height Offset Increase button 	Raise the tile boot or blade by the blade step increment.
Height Offset Decrease button 	Lower the tile boot or blade by the blade step increment.
Height Offset Coarse or Fine button	When you tap Coarse , the increase or decrease button moves the blade by the Coarse Blade increment. This enables you to move the blade by a larger increment. When you tap Fine , the increase or decrease button moves the blade by the fine increment.
Pitch Offset Increase	Raises the blade pitch relative to the design pitch.
Pitch Offset Decrease	Lowers the blade pitch relative to the design pitch.
Coarse (Pitch Offset)	When you tap Coarse, the increase or decrease button moves the blade by the Coarse Pitch increment. This enables you to move the blade pitch by a larger increment.

Point and slope mode

1. At the *Run* screen, tap  to open the WM-Drain panel.
2. Go to the *Install* tab of the panel. Use the controls for installation or ditch cleaning.

Control	Explanation
Survey	Tap to open the <i>Survey</i> screen where you can survey the section line you will design.
Design	Tap to open the <i>Design</i> screen where you can select a section line and then edit the design. Note – A white cross displays on the <i>Run</i> screen to show both the horizontal and vertical location.
Mode	<ul style="list-style-type: none"> • Autoslope: Creates sloped tile or surface drainage targeting the optimal depth defined on the Design tab. • Slope: Creates consistently sloped tile or surface drainage. From the starting point, the vehicle levels at a constant slope, regardless of direction. • Constant Depth: Use to collect a live, rolling survey of the ground surface. This survey is passed in real time to the control system, which enables it to run at the specified depth above or below the ground surface. The constant depth mode can only be accessed when you have properly configured manual guidance, Autopilot or EZ-Pilot. Run depth is defined by setting the Height Offset value to the desired depth. Examples: <ul style="list-style-type: none"> • For a consistent depth of 4.0' (1.22 m), adjust the Height Offset to -4.0' (-1.22m). • For a consistent height of 6" (0.15 m) above the ground surface, adjust the Height Offset to 6" (0.15cm). <p>This mode requires two RTK-enabled receivers are available and assigned on the system. One of the RTK-enabled receivers:</p> <ul style="list-style-type: none"> • Is not required to be an internal receiver • Must be assigned to the appropriate guidance plugin/feature • Must be mounted in front of the antenna used for WM-Drain
Pipe	<ul style="list-style-type: none"> • Pipe Type: Select the type of pipe to be installed. • Pipe Size: The size of the pipe to be installed.
Slope Increase	Increase the design slope by the Slope Adjust increment.
Slope Decrease	Decrease the design slope by the Slope Adjust increment.

Control	Explanation
Height Offset Increase	Raise the tile boot or blade by the Slope Adjust increment.
Height Offset Decrease	Lower the tile boot or blade by the Slope Adjust increment.
Height Offset Increase	Raise the boot or blade by the blade step increment.
Height Offset Decrease	Lower the boot or blade by the blade step increment.
Slope	Select a defined percentage of vertical drop for a horizontal distance traveled.
Coarse (Height Offset)	When you tap Coarse , the increase or decrease button moves the blade by the Coarse Blade increment. This enables you to move the blade by a larger increment.
Pitch Offset Increase	Raises the blade pitch relative to the design pitch.
Pitch Offset Decrease	Lowers the blade pitch relative to the design pitch.
Coarse (Pitch Offset)	When you tap Coarse , the increase or decrease button moves the blade by the Coarse Pitch increment. This enables you to move the blade pitch by a larger increment.
Auto	Set Automatics to the hydraulic valve. The blade or tile boot will be driven to the design depth depending on where you are located relative to the section line.
Logging	Tap to log coverage to be able to see on your map where you have been dependent on your implement width. A shape file will also be created with cut/fill and height information.

Define boot depth

You can define the boot depth by either of the steps below.

- Option 1: Enter the relative depth above and below the surveyed surface.
- Option 2: Enter a specific elevation in the Outlet Elevation entry box. The system calculates the other box.

Yield Monitoring operation

Yield Monitoring enables you to track the:

- Loads of grains harvested through the season for a field.
After the harvest is complete, use the Farm Works™ Mapping software to track loads in the office. See [Load tracking \(page 484\)](#).
- Variety of grains harvested throughout the season for a field that has an associated planting variety map.
After harvest is complete, use the Farm Works Mapping software to create and view a yield variety report to see a yield by variety comparison. See [Variety tracking \(page 483\)](#).

Yield Monitoring panel

To access the Yield Monitoring panel, at the *Run* screen tap .

The panel contains several views that you can navigate between.

Crop summary and details

The initial view shows each crop being harvested and summary information for each one.

Tap a crop/summary section to see more details about the crop.

To change the status items that show for a crop, at the Crop Name view tap **Edit Overview**.

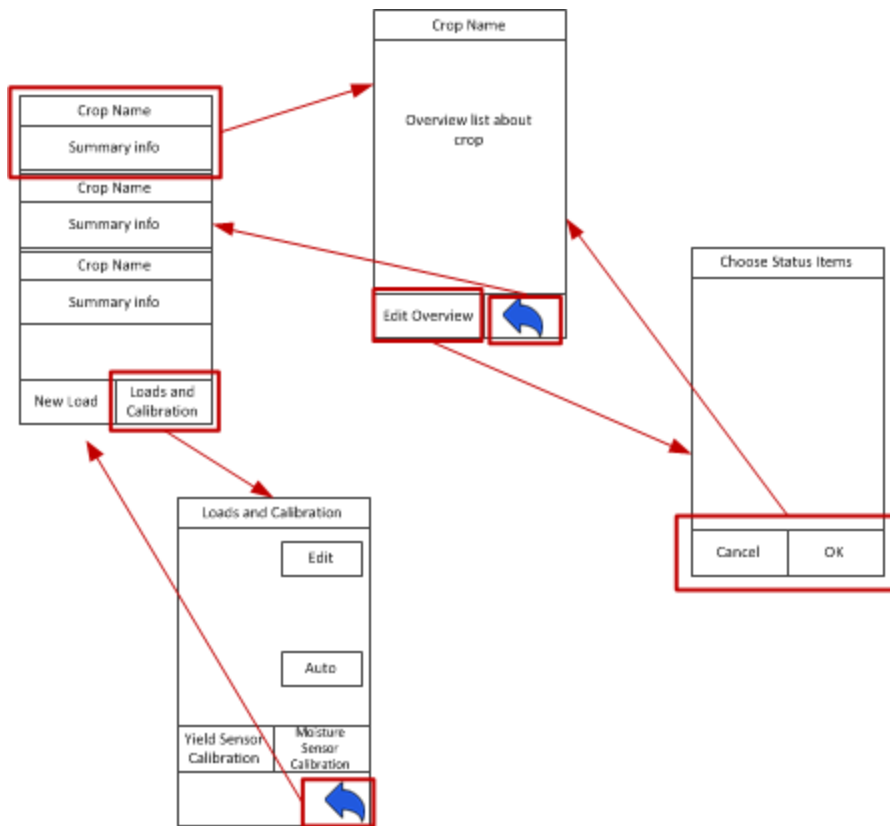

Variety tracking

For a field that has an associated planting variety map, Yield Monitoring enables you to track the variety of grains harvested throughout the season.

Variety map

When you are planting or seeding and are , a variety map layer is created within the Field folder if you are using either:

- Field-IQ crop input control system
- Serial Rate Control

When you open the client, farm, and field and create a harvest event, the system automatically loads the variety map layer into the background on the screen.

Note – Set up the implement as a harvest operation if you want the variety map layer to display.

After harvest is complete, use the Farm Works Mapping software to create and view a yield variety report to see a yield by variety comparison.

Load tracking

Yield Monitoring tracks loads of grains harvested through the season for a field. After the harvest is complete, use the Farm Works™ Mapping software to track loads in the office.

At the *Load Details* screen, you can view for each load listed:

Item	Explanation
Load Name	Name you assigned to the load
Recorded Weight	The weight of the load
Scale Ticket Weight	
Recorded Moisture	
Scale Ticket Moisture	

Diagnostics

In this chapter:

System diagnostics	486
Advanced system diagnostics	486
CAN Bus data	487
Configuration data	487
Network diagnostics	487
Serial Comms	487
Autopilot diagnostics	488
EZ-Pilot diagnostics	490
EZ-Steer diagnostics	491
Field-IQ diagnostics	492
FieldLevel II diagnostics valve test	514
GPS status	514
GreenSeeker diagnostics	514
Row-Guidance diagnostics	515
Vehicle Sync diagnostics	517
Yield Monitoring diagnostics	518

This chapter covers diagnostics and troubleshooting.

System diagnostics

At the *Configuration* screen, select  System and then tap **Diagnostics**. Each tab contains specific information about the system:

- [Advanced system diagnostics \(page 486\)](#)
- [CAN Bus data \(page 487\)](#)
- [Network diagnostics \(page 487\)](#)
- [Serial Comms \(page 487\)](#)

Advanced system diagnostics

1. At the *Configuration* screen, tap  System and then tap **Diagnostics**.
2. Go to the **Advanced** tab.
3. Select the Diagnostics Level. This determines how much debugging information is logged in the program files.

Item	Explanation
1	Minimal level of information
6 (default)	Medium level of information
9	Highest level of information

4. At Swath Control Points, select whether to hide or show swath control points.

When the guidance line is a curve, it displays on-screen as a series of short straight sections joined together. Swath control points appear where these line segments meet.

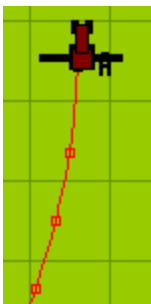

You can also use the *System Diagnostics* screen to view raw port data. For more information, see [Serial Comms \(page 487\)](#).

CAN Bus data

You can view CAN Bus data as the FM-1000 Plus application receives it.

To view the data:

1. At the *Configuration* screen, select  System and then tap **Diagnostics**.
2. Go to the CAN Bus tab.
3. To view the data from a port, tap **View**. The port diagnostics screen for that port displays.
4. To capture data, tap the **Capture** button. Approximately five seconds of serial data is captured and then displays on the screen. You can review the data or capture another snapshot of data.
5. To close the screen, tap **OK**.

Configuration data

1. To view FM-1000 Plus application configuration information, tap .
2. The *Home* screen shows:
 - FM-1000 Plus application firmware information
 - Autopilot controller information
 - GPS receiver and correction method information
 - Vehicle make and model

Network diagnostics

1. At the *Configuration* screen, tap  System and then tap **Diagnostics**.
2. Go to the **Network** tab.

The status of various network connections display.

Serial Comms

You can view raw serial data as the FM-1000 Plus application receives it. This can be useful for analyzing the GPS signal.

To view the raw serial data:

1. At the *Configuration* screen, select  System and then tap **Diagnostics**.
2. Go to the SerialComms tab. This diagnostics screen shows each of the connectors (ports) on the display harness and the number of data packets that have been sent and received.
3. To view the raw data from a port, tap **View**.
4. To capture data, tap **Capture**. Approximately five seconds of serial data is captured and then displays on the screen. You can review the data or capture another snapshot of data.
5. To close the screen, tap **OK**.

Note – Text shown in green is incoming data. Text shown in red is outgoing data.

Autopilot diagnostics

1. At the *Configuration* screen, select  Autopilot.
2. Tap **Diagnostics**. The *Vehicle Controller Setup - Guidance* screen displays. From this screen, you can access information on:
 - [Guidance](#)
 - [Steering](#)
 - [Details](#)
 - [Fault log](#)
 - [Warnings](#)

Controls

The following buttons are available on every tab:

- **Engage:** You can tap to engage or disengage the system. The button also shows the current engage state. When this button is red, tap it to see the fault that is preventing the automatic mode.
- **View Fault Log:** Tap to view [faults](#).
- **View Warning:** Tap to view [warnings](#).

Guidance tab

Section	Explanation
Offline distance graph	A graph of offline distance over time. Useful for diagnosing problems with the vehicle coming online and staying online.
GPS status	Current GPS position fix quality and number of satellites
Heading error	The difference between vehicle heading and path heading
Roll	Current roll value calculated by the system
Direction	Current vehicle direction: Forward, backward, or stopped
Cross Track Error	Numeric value of the offline distance
On-screen lightbar	Visual representation of offline distance
Heading	Current vehicle heading calculated by the system
Speed	Current vehicle speed calculated by the system
1PPS	Shows whether the 1PPS signal from a GPS receiver is detected
Aggressiveness	A slider to adjust the aggressiveness of the steering system.
Nudge	Enter the increment of distance you want for nudging.

Steering tab

Section	Explanation
PWM status	Shows the current PWM signals being sent to the electro-hydraulic valve. This is an indication of whether the system is attempting to turn left or right.
Steering command override	Bypasses the normal steering command to the wheels. With this feature, you can force a certain angle of turn and make sure that the system responds as expected.
Steering angle	Required angle: The angle that the system is trying to attain Steering angle: Where the system calculates the wheels are pointing
Enable	
Reset	

Details tab

Section	Explanation
Diagnostics	Vehicle and configuration specific diagnostics. Up to nine diagnostics can be shown.
Accelerometers	Raw voltage and scaled G-force for each of the system's accelerometers
Vehicle voltage	Input voltage currently being fed into the Autopilot system from the vehicle's electrical system
Vehicle voltage	Input voltage currently being fed into the Autopilot system from the vehicle's electrical system

Autopilot Faults screen

The *Autopilot Faults* screen lists all faults on the Autopilot controller. To access this screen tap **View Fault Log**.



Item	Explanation
Active	Faults that are currently active
History	Faults that have previously occurred
Cancel	Tap to close the screen.
Refresh Fault Lists	Tap to see the latest faults.
Clear History	Tap to clear historical faults.
Close & Clear Faults	Tap to clear all faults and close the screen.

Warning screen

When you are viewing the vehicle diagnostics screens, the **View Warning** button flashes red if there is an active warning. To view any active warnings, tap the button.

EZ-Pilot diagnostics

The *EZ-Pilot Diagnostics* screen contains the statistics for the IMD-600 and SAM-200 and inertial information.



1. At the *Home* screen, tap .
2. At the *Configuration* screen, tap  EZ-Pilot and then tap **Diagnostics**.
The *EZ-Pilot Diagnostics* screen displays.

IMD-600 status	Explanation
Status	Status of the system's connection to the IMD-600
Version	Firmware version of the IMD-600
Serial Number	Serial number of the IMD-600



SAM-200 status	Explanation
Status	Status of the system's connection to the SAM-200
Version	Firmware version of the SAM-200
Serial Number	Serial number of the SAM-600
Temperature	Temperature of the SAM-600
Voltage	

3. To view faults, tap **View Fault Log**.
4. To adjust the steering performance of the system, tap **Steering Performance**. See [EZ-Pilot system calibration \(page 202\)](#).

EZ-Steer diagnostics

1. At the *Home* screen, tap .
2. At the *Configuration* screen, tap  EZ-Steer and then tap **Diagnostics**. The *EZ-Steer Diagnostics* screen displays the SCM statistics and inertial information.
3. To view faults, tap **View Fault Log**.
4. To adjust the steering performance of the system, tap **Steering Perf**. See [EZ-Steer system calibration \(page 208\)](#).

Field-IQ diagnostics

1. At the *Home* screen, tap .
2. At the *Configuration* screen, tap  Field-IQ and then tap **Diagnostics**. The *Field-IQ Diagnostics* screen displays.

Operations tab

On this tab, you can:

- [Test optional switch box \(page 398\)](#) if you are using an optional section switch box
- [Enter values manually \(page 397\)](#)
- [Enable sections \(page 397\)](#)

Status Item	Explanation
Control Mode	Auto or Manual
Rate Switch Mode	Manual, Rate 1 or Rate 2
Applied Rate	The rate being applied
Current Flow	Relation of material being applied to time
Control Speed	Speed you are moving
Master Switch	Indicates which switches have been assigned to each section.
Current Pressure	

Tap **View Error Log** to see all errors listed since the last time the log was cleared.

Tap **Section Test** to begin a sequence of engaging each section and groups of sections.

The color coding for the sections are:

Section Number Tab	Section Indicator Graphic	Section is...	Section switch is...
Not indented	Red	Not armed	Off
Not indented	Gray	Not armed	On
Indented	Red	Armed	Off
Indented	Green	Armed	On

Testing section switches

Testing the switches from the Diagnostic screen is useful because you do not have to open a field or set a manual speed and manual coverage to make the section switches active.

At the Operation tab:

1. Arm the sections by tapping on the box with the sections you want to turn on.
2. Flip the section switches to test that they are working properly and are in the correct order.

Hardware tab

On this tab, the control modules are listed with the:

- Serial number of the module
- Position on the implement
- Firmware version
- Status of CAN connection
- Tx/Rx number of packets

Row Monitor tab

The status column of this screen indicates:

- Disabled: Sensor is not detected.
- Off: Sensor is detected but is not actively looking for seed.
- On: Sensor is detected and is looking for seed. (The field is open with system planting.)

Field-IQ faults and troubleshooting

Faults

Message That Displays	Explanation	Possible Causes/Actions
Field-IQ devices not found.	One or more Field-IQ system devices in the current implement configuration are not present.	Check: <ul style="list-style-type: none"> • Implement selection • Cabling and fuses • Field-IQ Diagnostics to identify missing modules • Field-IQ Setup
New Field-IQ devices need configuring. Please go to the Field-IQ Setup.	The Field-IQ system cannot be used without the master switch box.	Check: <ul style="list-style-type: none"> • Cabling • To see if CAN has been dropped. Check terminators.
The 12-section switch box has been disconnected. Sections will be controlled automatically.	Field-IQ can operate without the 12-section switch box. Section switching will depend only on existing coverage, field boundaries and exclusion zones. To get on-screen buttons for controlling sections, cycle power to the display and open the FM-1000 Plus application.	Check: <ul style="list-style-type: none"> • Cabling • To see if CAN has been dropped. Check terminators.
One or more Field-IQ system devices were disconnected.	One or more Field-IQ system devices have lost communication with the system.	Check: <ol style="list-style-type: none"> 1. Cabling and fuses 2. Field-IQ system Diagnostics to identify missing modules 3. Field-IQ System Setup
Rate not achievable For current target rate, the maximum speed is X mph.	The target application rate cannot be achieved within the configured maximum RPM at the current speed. The Field-IQ system is limiting the RPM to	Maximum flow/rpm has been set too low for desired speed and rate.

Message That Displays	Explanation	Possible Causes/Actions
	the configured maximum.	
Target rate may not be achieved for current target rate, the minimum speed is X\ mph.	At the current speed and target application rate, the required RPM is below the configured minimum RPM limit.	Minimum flow/rpm has been set to high for desired speed and rate.
The current coverage pattern will degrade system performance.	A "combing" coverage pattern is being generated because of a mix of on and off boom sections. This causes generation of many coverage polygons, possibly leading to degraded system performance.	Contact Trimble support.
Hydraulic motor over speed. or Hydraulic motor under speed	The hydraulic motor is not running at the commanded speed.	
Rate control stopped due to hydraulic motor over speed or Rate control stopped due to hydraulic motor under speed	The hydraulic motor was stopped due to it not running at commanded speed.	
Hydraulic motor stalled Rate control has been disabled. Toggle the master switch to re-enable rate control.		No RPM is being reported from encoder.
Check the hydraulic motor. It ran too fast (Rawson).	The hydraulic motor is not running at the commanded speed	Check hydraulic pressure.
Degraded GPS. Automatic section control has been disabled. Use switches to control sections.	The GPS positions are uncorrected. Due to potential inaccuracy of the positions, the Field-IQ system will not switch the boom sections automatically. You must control	

Message That Displays	Explanation	Possible Causes/Actions
	the sections manually through the switches.	
No GPS. Automatic rate and section control has been disabled. Please maintain speed at X mph.	The Field-IQ system is no longer adjusting the application rate. You are prompted to maintain the current speed. The last sentence appears only if the master switch was on at the time of the warning.	
Tank/bin level is getting low.	General system warning	
Using jump start speed. Please maintain speed at XX mph.	The GPS speed has been overridden with the jump start speed. You must drive at that speed to maintain the current target application rate.	
A power brown-out has occurred - check cabling and fuses - check power supply	Warning typically appears when system drops under 10 V.	Check: <ul style="list-style-type: none"> • Cabling and fuses • Power supply
Section controller reported over-current. Section and rate control have been disabled. Toggle the master switch to re-enable control.		Possible causes: Controller is drawing too much current. There is an electrical short somewhere.
Rate and Section Control Module Not Configured Please set the number of nozzles in the Field-IQ Setup	Number of nozzles has not been set.	
Controller Requires Valve Calibration		Go to the Valve Calibration screen to set the valve type.
Sprayer configuration error Check the settings on the Valve Calibration screen	The valve type, plumbing, or auxiliary valve setting is incorrect.	

Message That Displays	Explanation	Possible Causes/Actions
Flow meter configuration error Check the flow meter calibration	The flow meter calibration number has not been set.	
Shaft encoder configuration error Check the Shaft Encoder Constant in the Flow Calibration screen	The shaft encoder constant has not been set.	
Valve configuration error Check the valve calibration	The valve settings are not valid for the selected valve type.	
Unknown Field-IQ configuration error	This message shows if the FM-1000 Plus application does not understand the fault code that was received from the rate and section control module.	Check firmware versions. Report this fault to Trimble Support.
No flow detected	The Field-IQ system attempted to apply material, but the flow sensor failed to detect any flow.	Possible causes: <ul style="list-style-type: none"> • Incorrect flow calibration • Damaged or disconnected feedback sensor • Broken valve wiring
Attention Minimum flow XX gal/min is applying	The current target application rate and speed require a flow that is less than the configured minimum flow limit. The flow will be at that limit instead. Therefore, the actual applied rate will probably be above the target rate.	
Rate not responding.	The flow sensor indicates that the actual flow is not changing as expected.	Verify correct setup on the Valve Calibration screen. Perform a valve calibration. Inspect feedback sensor and rate control valve for damage.
Unstable flow control	The rate and section control module is having difficulty	Check the Plumbing setting on the Valve Calibration screen

Message That Displays	Explanation	Possible Causes/Actions
	maintaining the target flow, possibly due to an incorrect setup.	Reduce Field-IQ system aggressiveness.
Valve controller reported over-current		Possible causes: <ul style="list-style-type: none"> Control valve is drawing too much current. There is an electrical short somewhere.
Unknown valve error	This message shows if the FM-1000 Plus application does not understand the fault code that was received from the rate and section control module.	Probably due to incompatible firmware versions. Make sure that the correct firmware versions and the rate and section control module are installed. Report this fault to Trimble Support.
Unable to lock valve position.	An error occurred when attempting to lock the position of the control valve.	Probably due to incompatible firmware. Make sure that the correct firmware versions are installed on the FM-1000 Plus application and the rate and section control module.
Unable to start flow	An error occurred when attempting to control the valve.	Probably due to incompatible firmware. Make sure that the correct firmware versions are installed on the FM-1000 Plus application and the rate and section control module.
Field-IQ unknown internal error	This message appears if the FM-1000 Plus application does not understand the fault code that was received from the rate and section control module. Probably due to incompatible firmware versions.	Make sure that the correct firmware versions are installed on the FM-1000 Plus application and the rate and section control module. Report this fault to Trimble Support.
The second pressure entry must differ from the first Please enter a different	The pressure calibration process requires calibration at two different pressures. This	

Message That Displays	Explanation	Possible Causes/Actions
pressure	message indicates that you entered the same pressure twice. Note – Zero is a valid pressure for calibration.	
No pressure change has been detected Please change the system pressure	The pressure calibration process requires calibration at two different pressures. This message indicates that the report from the pressure sensor did not change when the second reading was taken.	The pressure in the system must be changed between readings, for example, by either: <ul style="list-style-type: none"> • Opening or closing a valve • Starting or stopping the pump. If this message persists after the pressure is changed, check the installation and wiring of the pressure sensor.
Invalid setup for flow calibration		Check: <ul style="list-style-type: none"> • Total Nozzles in the Boom tab in the Field-IQ system setup • Width in the Hardware tab in Field-IQ Setup • Flow meter number
Invalid setup for granular calibration		Check: <ul style="list-style-type: none"> • Shaft Encoder Constant • Width in the Hardware tab in Field-IQ Setup
The second gate height entry must differ from the first Please enter a different height	The gate height calibration process requires calibration at two different gate heights. This message indicates that you entered the same gate height twice. Note – Zero is a valid gate height for calibration.	
No gate height change has been detected	The gate height calibration process requires calibration at	If this message persists after the gate is moved, check the

Message That Displays	Explanation	Possible Causes/Actions
Please change the gate height	two different gate heights. This message indicates that the report from the gate height sensor did not change when the second reading was taken. The gate must be raised or lowered between readings.	installation and wiring of the gate height sensor.
Gate not open Please open the gate	The Field-IQ system is attempting to dispense material, but the gate height sensor indicates that the gate is closed. Or if the gate height sensor is disabled, you did not enter a non-zero gate height.	Open the gate, or enter a non-zero gate height. If the gate is already open, check the installation and wiring of the gate height sensor.
The spinner pulses per revolution setting is invalid Please check the spinner sensor setup		
The tank/bin is empty Please refill tank/bin	The tank/bin level sensor has reported that the tank/bin is empty.	If this is incorrect, check the tank/bin sensor installation and wiring.
Valve Calibration Not Started.	This shows only during auto valve calibration, which is not available in firmware version 4.0. For safety reasons, when running an auto valve calibration for anhydrous, the vehicle must be moving at a speed of at least 2 mph. If the vehicle speed is above 2 mph, check that the FM-1000 Plus application is receiving valid GPS positions.	The vehicle is moving too slow to begin the automatic valve calibration. Increase the speed of the vehicle and start the valve calibration again
Valve Calibration Failed	The vehicle is moving too slow to continue the automatic valve calibration.	Increase the speed of the vehicle and start the valve calibration again.
Please turn off the master switch	The Field-IQ system is in a mode in which material application is	

Message That Displays	Explanation	Possible Causes/Actions
	not expected. It is asking for the master switch to be turned off to make the system safe.	
<p>NH3 is an irritant and corrosive to the skin, eyes, respiratory tract and mucous membranes and is dangerous if not handled properly. May cause severe burns to the eyes, lungs and skin. Skin and respiratory related diseases could be aggravated by exposure. It is recommended that protective gloves, boots, slicker and/or pants and jacket, and chemical-splash goggles that are impervious to anhydrous ammonia are worn at all times.</p>	The application type is set to Anhydrous	
<p>Application width is different from the control width. Please visit Field-IQ setup to reconfigure settings.</p>	The total of the rate controller widths in the Hardware tab of the Field-IQ Setup must match the application width in the Implement Setup. A difference of about 0.4 inches is tolerated.	
<p>Application width is different from the control and section width. Do you want the control and section width to be automatically adjusted to match the application width?</p>	<p>This message could appear when you exit the Field-IQ Setup.</p> <p>The total of the rate controller widths in the Hardware tab of the Field-IQ Setup must match the application width in the Implement Setup. A difference of about 0.4 inches is tolerated.</p>	
Please select your NH3 unit	This messages shows if the application type is anhydrous and you attempt to exit the Field-IQ Setup without selecting	

Message That Displays	Explanation	Possible Causes/Actions
	the Anhydrous Units type ("lbs. Actual N" or "lbs. NH3") in the Features tab.	
The total number of rows assigned to sections (XX) exceeds the number of rows on the implement (XX) Press Continue to exit the Field-IQ Setup or press Edit to edit the row assignments.	This message may appear when you exit the Field-IQ Setup. The total of the numbers in the fields in the Sections tab exceeds the number of rows configured in the Implement Setup.	
XX implement rows are not assigned to sections Press Continue to exit the Field-IQ Setup or press Edit to edit the row assignments.	This message may appear when you exit the Field-IQ Setup. The total of the numbers in the fields in the Sections tab exceeds the number of rows configured in the Implement Setup.	
The number of nozzles must not be less than the total number of sections.	This message could appear when you exit the Field-IQ Setup. The total number of sections in the Hardware tab exceeds the Total Nozzles setting in the Rate tab. There must be at least as many nozzles as sections.	
Some devices have not been identified by serial number.	This message shows when you exit the Field-IQ Setup, if one or more of the serial number selection fields in the Hardware tab has no serial number selected.	
None of the expected Field-IQ system devices were found on the implement. Do you want to switch to another implement configuration?	The rate and/or section controllers that are identified in the current Field-IQ system configuration were not detected on the CAN bus.	
None of the configured	The rate and/or section	

Message That Displays	Explanation	Possible Causes/Actions
Field IQ devices are connected. Do you want to remove all of the missing devices from the Field IQ hardware configuration?	controllers that are identified in the current Field\ IQ configuration were not detected on the CAN bus.	
Fence nozzle is enabled The configured sections exceed the maximum that is supported Please reduce the number of sections	If the left fence nozzle is enabled in the Sections tab of the Field IQ Setup, the leftmost section controller must not have more than 11 sections. If the right fence nozzle is enabled in the Sections tab of the Field-IQ Setup, the rightmost section controller must not have more than 11 sections.	
Cannot flush because the system is not calibrated.	This message appears if you try to use the Manual Flush button in the Tank/Bin tab of the Field-IQ Setup when a rate controller is not yet calibrated.	
Rate and Section Control Module and Rawson Control Module can not be present at the same time. Please disconnect either device before continuing setup.	When using multiple rate controllers for 1 material, they must all be of the same type.	
Field-IQ has been disabled Rate and Section Control Module and Rawson Control Module cannot be present at the same time.	When using multiple rate controllers for 1 material, they must all be of the same type.	
Field-IQ has been disabled One or more of the Field-IQ system devices requires calibration		Go to the calibration screen to calibrate a controller.
Please enter a valid	The flow meter constant must	

Message That Displays	Explanation	Possible Causes/Actions
flowmeter calibration constant	be greater than zero.	
Weighed NH3 (End) must be less than Weighed NH3 (Start).	This appears during anhydrous flow calibration. The process requires you to enter the weighed amounts of NH3 at the start and end of a run. If this warning appears, it is likely that you transposed the two amounts.	
No target rate The flush cannot be performed until a target rate has been set Please select a target rate	This will appear if you try to flush when the current target rate is zero.	
The calibration cannot be completed because the quantity dispensed is zero. Press Edit to edit the quantity or Restart to restart the calibration.	The granular flow calibration requires you to enter the amount that was dispensed. This message shows if the entered amount was zero.	
Calibration Failed The flow calibration was cancelled	The granular calibration failed because you cancelled the calibration or an error occurred.	
Calibration Failed No flow was detected	The granular flow calibration failed because there were no pulses reported from the shaft encoder.	Check that the shaft turns during calibration. Check the installation and wiring of the shaft encoder.
Calibration Failed No material was dispensed	The granular calibration failed because you entered zero for the actual amount of material dispensed.	
The selected target rate and speed cannot be achieved. Reduce target speed or target rate.	This shows during granular calibration if the target rate and target speed that you entered require the shaft to turn faster than the maximum RPM that is set in the Limits tab in the flow	

Message That Displays	Explanation	Possible Causes/Actions
	calibration screen.	
The selected target rate and speed may not be achieved. It is recommended that the target speed be increased.	This shows during granular calibration if the target rate and target speed that you entered require the shaft to turn slower than the minimum RPM that is set in the Limits tab in the flow calibration screen. If you choose to continue, the Field-IQ system tries to run the system below the minimum RPM limit.	
The calibration constant changed significantly. For best results it is recommended that the calibration be repeated.	This message shows at the end of the granular calibration process, if the calibration constant changed by more than 30%.	
Motor failed to start	This message shows if the hydraulic motor fails to start during the Rawson Control Module Hydraulic Test.	
Motor stopped unexpectedly	This message shows if the hydraulic motor stops unexpectedly during the Rawson Control Module Hydraulic Test.	
The number of seeds dispensed did not match the number of seeds expected. Do you want to adjust the calibration constant in order to attain the target rate? Adjusting the calibration constant will alter the seed spacing.	This message may appear during calibration of a Rawson Control Module in a planter application. If the calibration test does not dispense the expected number of seeds, it is likely that the seed pick up is not operating perfectly. You can adjust the calibration constant to compensate for this but the seed spacing will be inconsistent where seeds are missed or doubled up.	
Calibration Failed	This message shows if the	

Message That Displays	Explanation	Possible Causes/Actions
The motor failed to turn	hydraulic motor fails to turn during calibration of a Rawson Control Module.	
Speed Too Low The vehicle is moving too slow for safe anhydrous application. Increase the speed of the vehicle.	For safety reasons, the Field-IQ system will not apply anhydrous in auto rate control mode at speeds below 2 mph. Either increase the speed or switch to manual mode.	

Anhydrous Rate Control troubleshooting

Unable to open valve.

1. Check all for proper valve type in rate control setup.
2. NH3 will not operate unless vehicle is moving over 1.5 MPH.

If settings are correct:

1. Disconnect the tank from the system.
2. Set the system up as a liquid.
3. Check that system has control of the valve when in manual rate. (During this procedure a no flow detected warning may appear. This is normal as there is no flow going through the system)
4. For FM-1000 integrated display 6.5 and up. System will run in diagnostics. (Only attempt after trying the previous steps.)

If system will run in diagnostics:

1. Check color of sections in the run screen. If sections are red there is an issue.
 - a. Check that system is not outside a boundary (open a new field to test)
 - b. Check that system is not over a previously applied area.
 - c. Check that system has a "fixed" GPS position.
2. Check that the material has not been disabled in the material detail screen.

Unable to reach target.

1. Check that system control components are sized properly.
2. See if the valve will open any further when set to manual rate. (if not, may be a tank or cooler limitation)

If system is sized properly for rate:

1. Check minimum and maximum flow settings.
2. Check that the flowmeter calibration is close to the number listed on the tag.

If settings check ok:

Check that control valve has been calibrated.

If PWM, check upper PWM limit under advanced parameters. May need to be set to 100%.

Rate fluctuates around target.

1. Check that a drive calibration has been performed.
2. Turn valve on and set rate switch to Manual to lock the valve.
3. If the rate still fluctuates check the flowmeter. (may be a cooler or a tank issue)

If the rate holds in manual, the valve needs to be tuned.

Any Implement Section Control troubleshooting

Section Control does not work.

1. Check that section control has been completely set up.
2. Check that switching type is set up properly. Boom valve Vs. air clutch
3. Check that auxiliary power and auxiliary I/O on the Field-IQ cables are connected. (if present)

If system is set up properly:

1. Run a flow calibration (catch test.) This will force the sections on and confirm that all cabling and connections are correct.
2. Operate the system in diagnostics. (FM-1000 Plus application only) Arm sections at bottom of the screen and perform a catch test.

If system works in diagnostics:

1. Check color of sections in the run screen. If sections are red there is an issue.
 - a. Check that system is not outside a boundary (open a new field to test)
 - b. Check that system is not over a previously applied area.
 - c. Check that system has a "fixed" GPS position.
2. If sections are yellow, boom valves should be on but no flow is detected.
3. Check that the material has not been disabled in the material detail screen.

Section control timing is off.

1. Check that all implement and vehicle measurements are correct. (Do not guess. These measurements are crucial for an accurate application.)
2. Check that start and end overlaps have not been adjusted to take care of timing issues. (These settings are only used for intentional overlap!)

If sections are coming on too late or shutting off too late:

1. Check that start and end overlaps are set to the desired intentional overlap.
2. Raise the on latency to allow the section to turn on earlier.
3. Raise the off latency to allow the system to start turning off earlier. Typically these settings are no more than 5 seconds. If they are higher double check implement measurements.

If sections are coming on too early or shutting off too early:

1. Check that start and end overlaps are set to desired intentional overlap.
2. Lower the on latency if the system is turning on too soon.
3. Lower the off latency if the system is shutting off too soon.
4. If settings are set to 0 and system is still not accurate check implement measurements.

Any Implement Sensor troubleshooting**Erratic sensor readings.**

1. Has sensor been calibrated?
2. Check that sensor is specified properly for the system.
3. Make sure the feedback voltage is in the right range. Pressure sensors are 0 to 5 V.

Erratic flowmeter / encoder readings.

1. Check all cabling and connections.
2. Check that the encoder constant is correct.
3. Check that there isn't a rate control issue by setting the Rate to Manual to lock the valve.
4. Check that the meter is sized properly for the application.
5. Check that there is nothing mechanically wrong with the meter.

Lift switch won't calibrate.

1. Check that the switch is plugged in
2. Check that switch works. Use a volt meter to check continuity on the switch. One way it will be open the other way it will be a closed circuit.

Switch is functional.

1. Jump the A and B terminals at the module harness to bypass cabling. If this works check all cabling.
2. If previous test didn't work set up a new implement. May be a bad module.
3. Check that the OEM harness is not supplying constant power to signal wire.

Planter Rate Control troubleshooting**Unable to turn motor.**

1. Check valve type in Rate control set up.
2. Check that hydraulic motor is receiving flow.
3. Check that motor will pass a drive calibration (PWM) only.
4. Perform a hydraulics test (Rawson).

If the motor will run in the calibration screen, check the operation of the system in the Field-IQ diagnostics screen.

1. Enter a manual speed and turn all sections on.
2. Arm all sections at the bottom of the screen.
3. If equipped with an implement switch make sure it is calibrated and shows the implement in the running position.

If motor ran in diagnostics screen:

1. Check color of sections in the run screen. If sections are red there is an issue.
 - a. Check that system is not outside a boundary (open a new field to test)
 - b. Check that system is not over a previously applied area.
 - c. Check that system has a "fixed" GPS position
2. Check that the material has not been disabled in the material detail screen.

Unable to reach target rate.

1. Check that maximum meter RPM has not been set to low. System defaults to 120 RPM
2. Rawson: Check that maximum motor RPM has been set to 300 RPM
3. Check Gear ratio and encoder constant (gear ratio needs to be figured from the encoder to the meter.)
4. Check info tab in the drive calibration screen. Make sure target rates and speeds are logical. If they are not this usually represents improper Field-IQ system set up.

If the settings check out okay:

1. Check that the control valve has been calibrated. If PWM, check upper PWM limit under advanced parameters. May need to be set to 100%.
2. Rawson: Check that the motor will reach 300 RPM in the hydraulic test. If it will and system still can't reach rate check that the gear ratio will allow system to reach target rate. Formula on page.

If the rate fluctuates around the target:

1. Check that a drive calibration has been performed.
2. If population monitoring is on, disable it to see target rate of the motors. If system holds rate it is a seed monitoring issue.

Drive calibration is performed (PWM):

1. Check that motor(s) have sufficient hydraulic flow.
2. Raise the PWM base frequency to 200Hz. (if PWM valve is a raven set to 120hz)

Rawson:

1. Check that drive is running above 100 RPM. Adjust gear ratio to achieve proper RPM.
2. Isolate the drive from the seed shaft. Make sure the drive operates properly with no load.

No communication with seed sensors.

1. Check that the Auxiliary I/O connector is plugged in.
2. A power cycle must be performed every time a cable is plugged in. The system only looks for the sensors on boot up. If they are not present it won't look for them until power is cycled.
3. Check that sensors are compatible with Field-IQ.

If the cables are connected:

1. Check for the right harness.
2. CT harness (John Deere) will always have pins 27 and 28 populated. These will be a power and a ground that provides 8 V to the sensors. **DO NOT ASSUME YOUR JD PLANTER HAS A CT HARNESS IT MAY HAVE BEEN RETROFITTED WITH A PM STYLE HARNESS.**
3. PM harness. (Also referred to as a Dickey John or DJ harness. Typically on all planters but JD.) These harnesses will have pins 24-27 populated. 24 and 25 are 8 V power. 26 and 27 are ground.

If you have the correct harness and have power to the sensor:

Check that all the sensors have 8 V power and 5 volt signal. If not this could represent a bad seed sensor harness.

Planter Seed Sensor troubleshooting

No communication with seed sensors.

1. Check that the Auxiliary I/O connector is plugged in.
2. A power cycle must be performed every time a cable is plugged in. The system only looks for the sensors on boot up. If they are not present it won't look for them until power is cycled.
3. Check that sensors are compatible with Field-IQ.

If the cables are connected:

1. Check for the right harness.
2. CT harness (John Deere) will always have pins 27 and 28 populated. These will be a power and a ground that provides 8 V to the sensors. **DO NOT ASSUME YOUR JD PLANTER HAS A CT HARNESS IT MAY HAVE BEEN RETROFITTED WITH A PM STYLE HARNESS.**
3. PM harness. (Also referred to as a Dickey John or DJ harness. Typically on all planters but JD.) These harnesses will have pins 24-27 populated. 24 and 25 are 8 V power. 26 and 27 are ground.

If you have the correct harness and have power to the sensor:

Check that all the sensors have 8 V power and 5 volt signal. If not this could represent a bad seed sensor harness.

Sprayer/Liquid Strip Till Rate Control troubleshooting

Control valve will not open.

1. Check valve type in Rate control set up.
2. Check that hydraulic motor is receiving flow (PWM)(pump servo).
3. Check that the product pump is on and producing flow (Servo).

For PWM:

1. Check that system will pass a drive calibration.
 - a. If not check that max flow setting has not been set too high. This setting is dependent of nozzle size. Refer to a tip chart.
 - b. If system still will not pass perform the calibration with no tips.
2. Sprayers with a pump arming relay:
Check that the pump arming relay is working by checking that the relay clicks on when the pump is armed. (there will be 12 V at terminal 85 on the relay)

For Servo:

1. Operate the valve in the drive settings screen.
2. Check that there is manual control of the valve in manual rate control. If there is no control check cabling.
3. If valve will work in manual, it may need to be calibrated to work in auto. See calibration procedure.

If the system ran in Diagnostics:

1. Check color of sections in the run screen. If sections are red there is an issue.
 - a. Check that system is not outside a boundary (open a new field to test)
 - b. Check that system is not over a previously applied area.
 - c. Check that system has a "fixed" GPS position.
2. Check that the material has not been disabled in the material detail screen.

Unable to reach target rate.

If unable to reach target:

1. Check that system control components are sized properly.
2. Check that nozzles are sized properly for sprayer.
3. See if the valve will open any further when set to manual rate. (if not may be a pump issue)

If system is sized properly for rate:

1. Check minimum and maximum flow settings.
2. Check that the flowmeter calibration is close to the number listed on the tag.

If settings check ok:

Check that control valve has been calibrated.

If PWM, check upper PWM limit under advanced parameters. May need to be set to 100%.

Rate fluctuates around target.

1. Check that a drive calibration has been performed.
2. Check that tips/orifices are sized appropriately for the system.

For PWM / Servo systems:

1. You may need to manually tune the valve.
2. Set valve to manual rate. With the rate in manual the valve should be "locked". If the rate still fluctuates check the pump and the flowmeter.

For Rawson:

1. Check that the drive is running above 100 RPM.
2. Isolate the drive from the pump. Make sure the drive operates properly with no load.

Spreader Rate Control troubleshooting

Unable to turn motor.

1. Check valve type in Rate control set up.
2. Check that hydraulic motor is receiving flow.
3. Check that motor will pass a drive calibration (PWM) only.
4. Perform a hydraulics test (Rawson).

If the motor will run in the calibration screen, check the operation of the system in the Field-IQ diagnostics screen.

1. Enter a manual speed and turn all sections on.
2. Arm all sections at the bottom of the screen.
3. If equipped with an implement switch make sure it is calibrated and shows the implement in the running position.

If motor ran in diagnostics screen:

1. Check color of sections in the run screen. If sections are red there is an issue.
 - a. Check that system is not outside a boundary (open a new field to test)
 - b. Check that system is not over a previously applied area.
 - c. Check that system has a "fixed" GPS position
2. Check that the material has not been disabled in the material detail screen.

Rate fluctuates around target.



1. Check that a drive calibration has been performed.
2. Set the Rate to Manual. With the drive "locked" the drive should be running steady. If the rate is still fluctuating check the encoder.

If drive calibration is performed, check that motor(s) have sufficient hydraulic flow.



For Rawson:

1. Check that drive is running above 100 RPM. Adjust gate height to achieve proper RPM.
2. Isolate the drive from the shaft if possible (try to minimize the load on the drive.) Make sure the drive operates properly with little or no load.

FieldLevel II diagnostics valve test

1. At the *Home* screen, tap .
2. At the *Configuration* screen, tap  FieldLevel II and then tap **Diagnostics**.
3. You can test valve functionality at any time at this screen without the need for a GPS position or an active field design open by either tapping:
 - **Auto**: To engage the system (this sets the current elevation as Target Height = 0.0) and tests its response as height offsets are added or subtracted from the current elevation, based upon the current coarse offset entered into the system
 - **Up or Down**: To manually stroke the valve to 100% command in the required direction to verify valve performance and wiring accuracy



GPS status

1. At the *Home* screen, tap .
2. At the *Configuration* screen, tap  GPS Receiver and then tap **Diagnostics**. The *GPS Status* screen. Use this screen to check that the GPS receiver is outputting the expected data.

To analyze the GPS signal, see [Serial Comms \(page 487\)](#) to view raw serial data.

GreenSeeker diagnostics

The *GreenSeeker Diagnostics* screen reports on the quantity of sensors detected on system and any error conditions.

1. At the *Home* screen, tap .
2. At the *Configuration* screen, tap  GreenSeeker and then tap **Diagnostics**. The *GreenSeeker Diagnostics* screen displays.

The hardware and firmware version information at the top of the diagnostics screen indicates the FM-1000 Plus application and RT200 are communicating.

Incorrect data

The RT200 system monitors the sensors for proper operation, and if a sensor reports incorrect data, the data is not included in the rate control calculation. Incorrect data can come from mud on the sensor lenses, sensors viewing concrete, snow, wet asphalt, or other non soil or non plant surface.

Error conditions



Error conditions include sensors disconnected from the CAN bus, or a sensor transmitting invalid data.

Invalid data could occur if the sensor malfunctions, or more commonly, if it is seeing a target other than plants and soil.

For example, when setting up the system, the sensors may be pointed into the air or against wet asphalt. Either of these conditions will likely generate an error code from a sensor.



Error	Code	Explanation
-1	Red > NIR	Red reflectance higher than NIR
-2	BOTH < .01	Both reflectances are below 0.01
-3	RED < .01	Red reflectance below 0.01
-4	NIR < .01	NIR reflectance below 0.01
-5	BOTH > .98	Either reflectance above 0.98
-9	NIR < .015	NIR net reflectance below 0.15

Row-Guidance diagnostics

1. At the *Home* screen, tap .
2. At the *Configuration* screen, tap  Row Guidance and then tap **Diagnostics**.

Item	Explanation
Offline Distance	
Status	Status of the sensor
Enable / Disable	Tap to enable or disable sensors
Voltage	Voltage for the left and right sensor
Voltage status	Status for the left and right sensor

Vehicle Sync diagnostics

1. At the *Home* screen, tap .
2. At the *Configuration* screen, tap  Vehicle Sync and then tap **Diagnostics**. The *Vehicle Sync Diagnostics* screen displays.
3. Check the signal quality for the WiFi connection.
4. View the other vehicles that are on the selected channel.

Yield Monitoring diagnostics

1. At the *Home* screen, tap .
2. At the *Configuration* screen, tap  Yield Monitoring and then tap **Diagnostics**. The *Yield Monitoring Diagnostics* screen displays.

Status tab

The *Status* tab includes information on the optical and moisture sensors.

Optical Sensor Item	Explanation
Noise level	<p>Indicates how clean the optical sensor signal is and if the noise level is too high.</p> <p>This number should be less than 30% for best performance. If larger values are seen, check the following:</p> <ul style="list-style-type: none"> • Optical sensor interference • Worn paddles • Optical sensors protruding too far into the chamber • Installation in the wrong location (too low on elevator).
Elevator speed	<p>Frequency of paddles, typically 15 Hz to 20 Hz</p> <ul style="list-style-type: none"> • Unusually low numbers: Indicate the system is not seeing the paddles This most likely occurs when running empty. Inspect the optical sensor installation. • Unusually high numbers: Typically be accompanied by large noise levels Inspect the optical sensor installation.
Percent Dark	<p>The duty cycle.</p> <p>This data can be used to determine if you are close to exceeding the capacity of the combine.</p>

Moisture Sensor Item	Explanation
Sensor Value	Percent of moisture and the raw sensor value Can be used by support or engineering if troubleshooting is necessary.
Temperature	

Yield Monitor error messages

State 1 - During boot up

Cause	Actions
60 Series Moisture unit Head unit Armrest unit 70 Series Moisture sensor CC1 unit Cab unit Corner post YM 2000 Cannot detect YM 2000 Serial port	<ol style="list-style-type: none"> 1. Ensure that the correct cable is installed. 2. Ensure the FM-1000 Plus application is communicating with the CAN bus (system / diagnostics / serial port / Port A/B). Is there another value other than zero for CAN messages? 3. For 60 Series Combines: Check if Crop Type will change on the Greenstar display after Crop Type on the FM-1000 Plus application has been changed. 4. For 70 Series Combines: Change the Crop Type in the command center and make sure it changes on the FM-1000 Plus application. 5. Raise the head up or down to see if the FM-1000 Plus application will show a change for header height. 6. If step 1 and step 2 resolve the issue, log field data.

State 2 - During boot up

Cause	Actions
Never sees the armrest, header unit, moisture sensor, or reports which one is not visible by the FM-1000 Plus application.	<ol style="list-style-type: none"> 1. Ensure the FM-1000 Plus application is communicating with the CAN bus (system / diagnostics / serial port / Port A/B). Is there another value other than zero for CAN messages? 2. For 60 Series Combines: Make sure Moisture Sensor has version 1.20C loaded. 3. For 60 Series Combines: Check if Crop Type will change on the Greenstar display after Crop Type on the FM-1000 Plus application has been changed. 4. For 70 Series Combines: Change the crop type in the command center and make sure it changes on the FM-1000 Plus application. 5. Raise head up or down to see if the FM-1000 Plus application shows a change for header height.

State 3 - During boot up

Cause	Actions
Will show which controller is not visible (armrest, header unit, moisture sensor).	<ol style="list-style-type: none"> 1. Ensure the FM-1000 Plus application is communicating with the CAN bus (system / diagnostics / serial port / Port A/B). Is there another value other than zero for CAN messages? 2. For 60 Series Combines: Make sure Moisture Sensor has version 1.20C loaded. 3. For 60 Series Combines: Check if Crop Type will change on the Greenstar display after Crop Type on the FM-1000 Plus application has been changed. 4. For 70 Series Combines: Change the crop type in the command center and make sure it changes on the FM-1000 Plus application. 5. Raise head up or down to see if the FM-1000 Plus application shows a change for header height.

State 4

Cause	Actions
Display has lost communication with the CAN bus.	<ol style="list-style-type: none"> 1. Check cabling. 2. Recycle power (power down the display and the combine and wait 20 seconds before powering the display and the combine back up). 3. Make sure other logging devices are not connected to the CAN bus (disconnect Mobile Processor or GS2 display).

Yield Monitor troubleshooting

The FM-1000 Plus application is not mapping.

1. Make sure the display Header Height setting is lower than John Deere's setting.
2. Ensure that the crop type is the same.
3. The machine must be in normal harvesting operation mode.

The FM-1000 Plus application stops mapping periodically through the field.

Cause: The header could be raising and lowering past the setting for Stop Logging Header Height.

Action: Increase the Header Height setting on the FM-1000 Plus application.

FM-1000 Plus application yield information does not match John Deere's information.

Cause: Different crop types may be selected.

Action: Verify the crop types match in both displays.

The display shows a major jump or extremely different weight values from those shown on the John Deere monitor.

Cause: The Stop Head Height setting is lower than what the John Deere monitor shows. The John Deere monitor could be logging more data than the FM-1000 Plus application logs, therefore showing a larger value.

Action: Set the Head Height to 100% on the John Deere display.

Yield Monitoring warning messages

Warning message	Explanation
Unable to calibrate yield monitor.	Occurs when tare calibration fails.
Invalid selection. Please select one of the calibration types below this item.	The user clicked on the wrong line in the Yield Monitor <i>Calibration</i> menu.
No Connection. Please check connections.	User attempted to calibrate a device that is not connected.
Failed to detect yield sensor!!!	Some setup parameters cannot be edited because the yield monitor is not connected.
Yield sensor has not uploaded configuration into FmX.	Some setup parameters cannot be edited because they have not been received from the yield monitor.
Trimble Yield Monitor not found—check cabling and fuses—check Yield Monitor Setup.	Yield monitor not detected.
Trimble Moisture Sensor not found—check cabling and fuses—check Yield Monitor Setup.	Moisture sensor not detected.
One or more Yield Monitor devices were disconnected.	A device has been disconnected.
Moisture out of range. Check the sensor is positioned properly and not being struck by paddles, and there is no free water or wet soil on sensor surface.	Bad reading received from moisture sensor.
The label cannot be oriented along the same axis as the connectors.	Invalid selection in IMU sensor orientation setup.
Choose the options that match the Trimble Yield Monitor's mounting orientation.	Attempting to perform roll calibration before setting a valid orientation.
Would you like to calibrate the roll sensor?	
For accurate Roll Offset calibration you must turn the vehicle around.	User did not turn the vehicle around for second step of roll calibration.
Please select one or more loads to use for calibration. Tap the check mark to select a load.	Attempted to run load calibration with no loads selected.
Would you like to apply the calibration to the current field?	

Warning message	Explanation
Current field is successfully recalibrated.	
Unable to recalibrate current field.	Calibration was unable to be applied to field, possibly due to invalid data in field.
The calibration will be cleared. Are you sure you want to do this?	User tapped Reset in a calibration screen.
The yield sensor calibration has been reset.	User confirmed yield calibration reset.
The moisture sensor calibration has been reset.	User confirmed moisture calibration reset.
The temperature sensor calibration has been reset.	User confirmed temperature calibration reset.
No load information is available. You must record some data by harvesting some crop before you can run this calibration.	There are no loads for the current crop type.
This load is too small to be used for calibration or contains invalid data.	The load data is not valid for calibration, usually because the load is too small.
Optical sensor is not responding.	Optical sensor failed to respond during tare calibration.
No loads have been recorded. Use the 'New Load' button on the map screen to record a load.	Displayed in load details dialog if there are no loads for the current crop type.
This load cannot be deleted because it is used in the yield calibration.	Loads that were used for the current yield calibration cannot be deleted.
This load cannot be deleted because it is used in the moisture calibration.	Loads that were used for the current moisture calibration cannot be deleted.
Loads cannot be recorded when there is no field open.	Occurs when tapping New Load in the diagnostic screen if no field is open.
You have chosen to delete some loads. Are you sure you want to do this?	User tapped OK after selecting loads for deletion in Load Details screen
The system is not yet ready to delete fields or events.	The FM-1000 Plus application needs some time to determine whether deletion of the field/event would remove a load that was used for calibration. Try again later.
Accepting the new test weight will affect the current calibration.	
The average moisture will be reset to the	Manual moisture will cause the average to be

Warning message	Explanation
manually entered moisture setting.	reset.
Do you want to reset average moisture and recalculate dry yield?	Requesting confirmation when setting manual moisture.
Closing this field will cause your current load being recorded to be automatically finished.	The user has chosen to close the field before ending the load.
Would you like to clean out the moisture sensor?	The FM-1000 Plus application offers to clean out the Trimble moisture sensor when shutting down.
Would you like to begin a new load? The Test Weight for the new load is XXXXX.	User tapped New Load and New/End Load Confirmation is enabled in setup.
What would you like to do? End Load, ends the current Load. Cancel, continue with the current Load. New Load, closes this Load and starts another Load.	User tapped End Load and New/End Load Confirmation is enabled in setup.
This operation will delete one or more loads that were used in the most recent yield or moisture calibration. These loads will not be available for use in any future recalibration.	User is deleting a client, farm, field or event that contains one or more loads that were used in the current calibration.
CLAAS YIELD MONITOR: WARNING. Uninitialized.	Error in communication with Claas yield monitor.
CLAAS YIELD MONITOR: WARNING. Cannot configure CAN port.	Error in communication with Claas yield monitor.
CLAAS YIELD MONITOR: WARNING. Cannot detect the CLAAS CAN bus.	Error in communication with Claas yield monitor.
CLAAS YIELD MONITOR: WARNING. Cannot configured Yield Monitoring.	Error in communication with Claas yield monitor.
CLAAS YIELD MONITOR: WARNING. Lost CAN communications.	Error in communication with Claas yield monitor.
CLAAS YIELD MONITOR: WARNING. Error state.	Error in communication with Claas yield monitor.
CLAAS YIELD MONITOR: WARNING. Head configuration differs between the FmX and CEBIS.	The implement width in the FM-1000 Plus application setup must be set to match the width that was set in the Claas yield monitor.
YIELD MONITOR: CAN bus error (state#XX). Failed to detect the following device(s):-.....	John Deere moisture sensor, head unit or armrest unit not detected. Check port

Warning message	Explanation
	selection.
YIELD MONITOR: CAN bus error (state#XX).	Unknown error when communicating with John Deere yield monitor.
YIELD MONITOR: Failed to update crop type!!!	Unable to set grain type in John Deere yield monitor. Probable communication error.
YIELD MONITOR: Configuration Error (state#XX). Verify the FmX is connected to the CAN bus and CAN bus/combine series configuration.	Lost connection with John Deere yield monitor.
YIELD MONITOR: Moisture sensor is not connected	Trimble moisture sensor connection error.
YIELD MONITOR: Temperature sensor is reporting values outside of a valid range	Bad reading received from temperature sensor.
YIELD MONITOR: Field changed on YM2000. Verify that the Crop type is not inadvertently changed on YM2000	YM2000 reported a "field" error.
YIELD MONITOR: Load changed on YM2000. Verify that the crop type is not inadvertently changed on YM2000.	YM2000 reported a "load" error.
YIELD MONITOR: Cannot Detect YM2000 Serial Port (state#XX) !!!	Lost connection with YM2000 yield monitor.

Glossary

A

A+ line

A guidance line you define on your field. The A+ line is defined fixing a point, then heading in a direction. Guidance lines are for use with automated steering.

AB line

A guidance line you define on your field. You set a beginning point (A) and an end point (B). You use guidance lines for use with automated steering.

Accelerometer

A device that measures non-gravitational acceleration.

Access path

A space between your guidance lines. They can be useful if there is road (or other field feature that breaks the consistent flow of swaths) through the middle of your field.

Aggressiveness

The measure of how strongly the system makes steering changes.

Autonomous GNSS positioning

Autonomous GNSS positioning uses no corrections. The rover receiver calculates its position using only the GNSS signals it receives. This method does not have high absolute accuracy, but the relative accuracy is comparable to the other methods.

RTK GNSS positioning uses the RTK positioning method to achieve centimeter-level accuracy. To use the RTK method, you must first set up a base station. The base station uses a radio link to broadcast RTK corrections to one or more rover receivers.

B

Benchmark

A point on the field with GPS coordinates assigned to it.

Blade height

Current height of the blade shown as a relative height or a GPS height depending on settings selected.

Boot depth

Depth of the boot when installing tiles or the depth of the blade when cleaning surface ditches.

Boundary

A line indicating the border surrounding a field.

C**CenterPoint™ RTK for radio**

Positioning correction service for radio communication systems. Requires access to a base station located within a eight-mile radius (approximately) from your farm. An RTK base station sends corrections via a radio transmitter to a mobile receiver attached to your vehicle. Works well for farms within 8 miles of an established RTK base station or base station network, without line-of-sight obstructions such hilly terrain or an abundance of trees.

CenterPoint™ RTX™

Positioning correction service for satellite communication systems. Delivers GPS or GNSS enabled corrections via satellite directly to your receiver. Does not require a base station or cellular data plan. CenterPoint RTX corrections are provided on as subscription basis.

CenterPoint RTX for cellular

Positioning correction service for cellular communications. Delivers corrections via cellular network directly to your receiver. Requires a cellular data plan.

CenterPoint™ VRS™

Virtual reference station. Positioning correction service for cellular communication systems. Enables RTK (Real-Time Kinetic) corrections over a large geographic area where robust cellular data coverage is available. Provides high accuracy for guidance applications throughout the whole coverage area. Requires a cellular data plan. Uses a cellular communication modem, such as the DCM-300 or Ag3000. Relies on CORS.

Clean grain elevator

After grain has been separated from the rest of the plant, the clean grain auger moves the grain from the separator to the grain bin.

Client

The customer for whom the work is being done.

Composite slope

The true angle of the fall of the design. In other words, the angle of the slope when two slope angles are combined.

Controller orientation

Correctly associate the outputs of the Autopilot controller sensors with the direction of the vehicle.

Correction age

Time since the last GPS correction was received.

Correction service

A service which provides corrections to create a higher GPS accuracy.

CORS network

Continuously Operating Reference Station. A network of GPS/GNSS reference stations situated within the coverage area to transmit RTK (Real-Time Kinetic) corrections to the cellular modem. The distance between the reference stations and the modem on the vehicle does not affect accuracy. CORS works well in areas with spotty RTK radio tower coverage.

Curved line

A guidance line you define on your field. You begin recording and drive until you are at the end of the curved line or segment, then stop recording. Guidance lines are for use with automated steering.

Cut

A point on the field where dirt needs to be removed. A cut occurs when the existing field is higher than the proposed field surface.

Cut/Fill ratio

Difference between the blade height (1) and the target height (4):

When cut (dirt to be removed) is displayed, the current ground is above the target. The height indicator arrow turns red and points down, which means that the blade needs to move down to reach the target height.

When fill (dirt to be replaced) is displayed, the current ground is below the target. The height indicator arrow turns red and points up, which means that the blade needs to move up to reach the target height.

D

Data Dictionary

A set of data that contains categories for entry data when you are setting up client, farm, field and event.

Design height

The height of the land called for in a design.

Design slope

The slope of the land called for in a design.

DGNSS

Differential GNSS positioning. The GNSS receiver uses corrections from WAAS/EGNOS satellites or from OmniSTAR HP, XP, G2, or VBS satellites. These differential systems use special algorithms to provide differential corrections that allow the rover receiver to calculate its position more accurately. Not all corrections services support the use of GLONASS satellites in their solution.

DGPS

Differentially corrected Global Positioning System (GPS).

E

EGNOS

European Geostationary Navigation Overlay Service. An [SBAS](#) operated by the European Space Agency.

Event

A precision agriculture activity on a particular field. For example: planting seed, applying fertilizer or lime, or spraying with fungicide, herbicide or insecticide.

F

Farm

A collection of fields.

Field

Settings created in the FM-1000 Plus application to represent an actual field, one or more parts of an actual field, or a group of two or more fields. Field profiles include guidance lines for steering, pivot patterns and landmarks.

Fill

A point on the field where dirt must be added. A fill occurs when the existing field is lower than the proposed field surface.

Freeplay

Movement in the steering linkage through which a movement of the steering wheel will cause no change in wheel angle.

Freeplay offset

A value entered to give the control system a way to account for freeplay during guidance.

G

GDD

Growing Degree Days. A measurement of heat units since planting above a prescribed base temperature.

GLONASS

A Russian space-based satellite navigation system.

GNSS

Global Navigation Satellite System. A system of GPS US and Russian satellites that provide information about geo-spatial positioning. A GNSS receiver can determine its longitude, latitude and altitude. In the future, GNSS will also use Chinese GPS satellites.

GPS

Global Positioning System. A space-based satellite navigation system. A GPS receiver can determine its position by using GPS satellites.

GPS autonomous positioning

A mode of operation in which a GPS receiver computes position fixes in real time from satellite data alone, without reference to data supplied by a base station. Autonomous positioning is the least precise positioning procedure a GPS receiver can perform, yielding position fixes that are precise to ± 100 meters.

H**HDOP**

The horizontal component of [PDOP](#).

Header height

A sensor that indicates the position of the head.

I**IMD**

Inertial Measurement Device.

IMEI

International Mobile Station Equipment Identity. A number to identify mobile equipment. The GSM network uses this number to identify valid devices. The IMEI number has no relationship to the subscriber.

Implement steering

A system that actively steers the implement being towed by a vehicle.

IMU

Inertial Measurement Unit. An electronic device that measures and reports on a vehicle's velocity, orientation, and gravitational forces, using a combination of accelerometers and gyroscopes.

Integrated radio

Trimble integrated radios contain a radio antenna integrated with the GNSS receiver or display in a single unit. These integrated radios receive corrections transmitted by Trimble GNSS RTK base stations.

L**Logging**

Also called coverage logging. Logging records the area that you have covered when you carry out an operation, for example applying fertilizer to a field.

License

A license enables a software feature, and is valid for an unlimited duration. A license does not need to be activated, but does need to be assigned to and delivered to a specific display. Assignment and delivery of a license occurs on the reseller portal.

M

Manual override

Required for platforms that employ a pressure transducer for the manual override function. Change the default only if the operation of the manual override function is unacceptable

Master benchmark

Before you can create a survey, you must set at least one point at a known location called a benchmark. When you create a benchmark, the GPS receiver obtains and records location information from the base station for that specific point in your field. The first benchmark you create on a field is the master benchmark and displays as an orange flag labeled **MB**. Field coordinates are calculated from this point.

Material

A product that is controlled by a PWM valve, Servo valve, or Rawson drive. You can use a planter (seed), liquid, granular seed and granular fertilizer, all of which have different setup parameters.

Multipath error

An error caused by the interference of the same signal reaching the receiver by two different paths: once via the direct path, and once via a reflection. A major cause of GPS errors.

N

NDVI

Normalized Difference Vegetative Index. Commonly used to measure plant health and vigor. $NDVI = \frac{(NIR_reflected - Red_reflected)}{(NIR_reflected + Red_reflected)}$.

NMEA standard

An electrical, hardware and data standard designed by the National Marine Electronics Association that dictates the content and format of communication between GPS receivers and other devices. NMEA messages include data that provides location and accuracy, the number of satellites being used, the dilution of precision and signal strength.

NEU

Nitrogen Use Efficiency. A percentage of nitrogen taken up by the plant. For example, an NUE of 60% means that 6 lbs. of nitrogen fertilizer is expected to be used by the plant that year for every 10 lbs. applied. For more information, visit www.nue.okstate.edu.

NRS

Nitrogen Rich Strip. An area for determining the amount of nitrogen being made available to the plant by the environment (mineralization, etc), and importantly this year's expected maximum yield potential and response to additional nitrogen.

O**OEM moisture sensor**

Moisture sensor installed by the combine manufacturer.

Offset

Difference between design height and target height. By using the offset buttons, you can create a plane that is parallel to the original design.

P**Parity**

When used with a serial port, an extra data bit is sent with each data character to detect errors in transmission.

PDOP

Position Dilution of Precision. A calculation that takes into account the satellites that can be seen, how high they are and their bearing. The outcome of the calculation is an estimation of how prone to error your GPS position is. The lower the value, the more accurate your position. You may wish to plan your field work for periods of low PDOP. Generally, the more satellites in view, the better (lower) the PDOP.

Pivot

A guidance pattern you define for your field by recording the outer circular boundary of the pivot area and then entering a value to compute the rows within the pivot. Guidance patterns are for use with automated steering.

R**RangePoint™ RTX™**

Positioning service for satellite communication systems. RangePoint RTX works with a built-in GNSS receiver. Does not require a base station or cellular data plan.

Rate switch for Field-IQ

Used to select Preset Rate 1, Preset Rate 2, or Manual Rate Control.

Real Time Kinematic (RTK)

A navigation technique to improve the information received from satellite-based positioning systems. Used with GPS, GLONASS and Galileo.

RI

Response Index. An indication of how the crop will respond this season to additional nitrogen.

Roll correction

Compensates for antenna height and static roll caused by minor variations in the navigation controller and the mounting of the GPS receiver.

Row

The individual row unit which seed comes from on the planter. This can be controlled individually as a single row section, or as a group with other rows in a multiple row section.

Run screen

The screen where you perform field activities.

S**SBAS**

Space Based Augmentation System. A system of Earth-based systems at points surveyed for location accuracy that measure satellites, signals and factors that can impact the signals. The SBAS then broadcasts corrections to satellite signals to improve accuracy.

Scintillation

Causes extreme fluctuations in signals that are received. Scintillation can be caused by turbulence that creates air pockets with different temperatures and densities.

Section

A number of rows or spray nozzles that are controlled by existing shut-off valve, Tru Count air clutches, or Tru Count LiquiBlock valves. A section can have either a single row/nozzle or multiple rows/nozzles depending on how the system is set up.

Section Control Module

Controls 12 sections/rows per module with up to 4 modules (48 module sections / rows).

Service

A service is a subscription to an application that lasts for a specific amount of time, such as one or two years. You associate a service with a specific display that can be delivered wirelessly, through a QR code included in an email or through download to a computer.

Signal Input Module

The signal input module (SIM) can interface with existing equipment inputs to control on-screen buttons and features.

Singulation

The percentage of time an individual seed is placed for every intended drop.

Slew time

The amount of time that the front wheels take to move from the far left to the far right position and back.

Slope heading

The heading direction of the slope.

Steering deadzone

The amount of pressure that the system must apply to the hydraulics before the wheels begin to turn.

Stop bit

A bit sent at the end of every character to enable the detection of the end of the character. Then the hardware can synchronize again with the character stream.

T

TAP

Tuning parameter for guidance algorithms.

Target height

Height on the target plane that the blade will attempt to reach. This is the design height (6) \pm the offset (5). When the blade reaches the target height, the height indicator arrow turns green.

V

VDOP

A measurement of the vertical [PDOP](#).

VI

Vegetation Index. A value that is calculated (or derived) from sets of remotely-sensed data used to quantify plant health, stress, and vigor.

VRA

Variable Rate Application. The rate of fertilizer or other chemical applied, based on information supplied to a rate controller.

W

Wheelbase

The distance between the front and rear axles. On tracked vehicles, the wheelbase is exactly half the length of the track.